

Ball screws

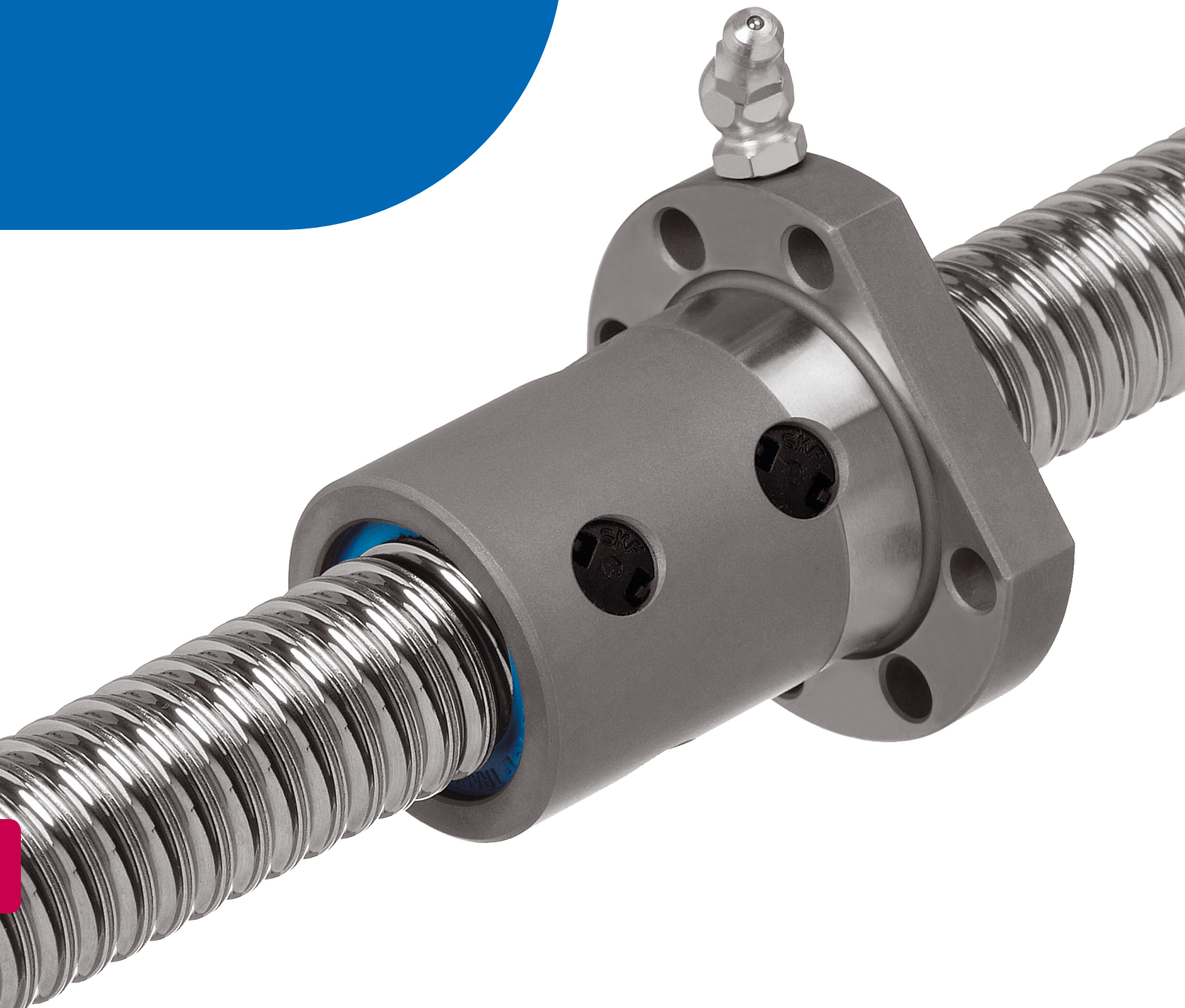



The SKF brand now stands for more than ever before, and means more to you as a valued customer.

While SKF maintains its leadership as the hallmark of quality bearings throughout the world, new dimensions in technical advances, product support and services have evolved SKF into a truly solutions-oriented supplier, creating greater value for customers.

These solutions encompass ways to bring greater productivity to customers, not only with breakthrough application-specific products, but also through leading-edge design simulation tools and consultancy services, plant asset efficiency maintenance programmes, and the industry's most advanced supply management techniques.

The SKF brand still stands for the very best in rolling bearings, but it now stands for much more.

SKF – the knowledge engineering company

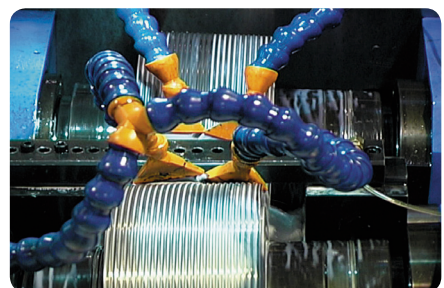
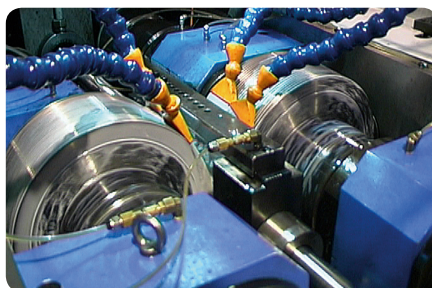
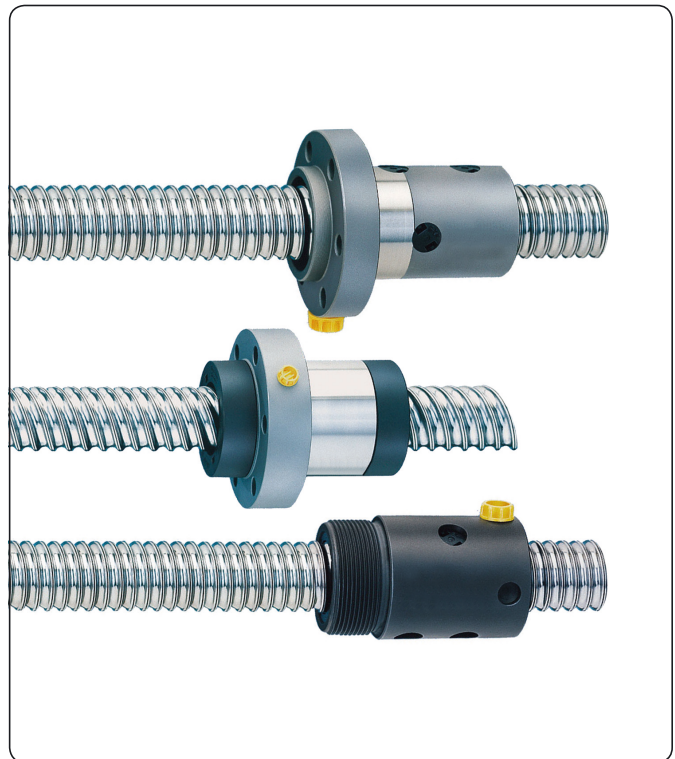
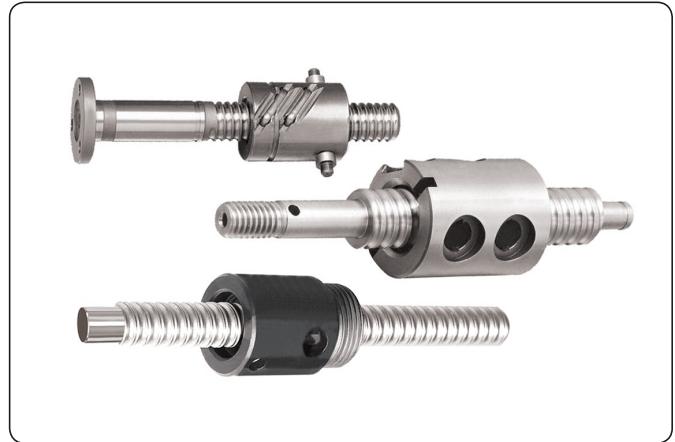

Contents

A Recommendations for selection

SKF – the knowledge engineering company	4
Overview: ball screw nuts	6
Basic concepts	8
Basic dynamic load rating (C_a)	8
Nominal fatigue life L_{10}	8
Service life	8
Equivalent dynamic loads	8
Fluctuating load	8
Static load carrying capacity (C_{0a})	9
Critical rotating speed for screw shafts	9
Permissible speed limit	9
Lubrication	9
Efficiency and back-driving	9
Axial play and preload	10
Static axial stiffness of a complete assembly	10
Screw shaft buckling	11
Manufacturing precision	11
Materials and heat treatments	11
Number of circuits of balls	11
Recirculation inserts	11
Working environment	11

B Recommendations for assembly

Assembly procedure	12
Radial and moment loads	12
Alignment	12
Lubrication	12
Designing the screw shaft ends	12
Operating temperature	12
Separating the nut from the screw shaft	13
Starting-up the screw	13

C Technical data

Lead precision according to ISO	14
---------------------------------------	----

D Product information

SD/BD/SH miniature screws	16
SDS/BDS/SHS miniature screws in stainless steel	18
SX/BX universal screws	20
Accessories for SX/BX nuts	22
SND/BND precision screws, DIN standard	24
PND preloaded screws, DIN standard	26
SN/BN precision screws	28
PN preloaded screws	30
SL/TL long lead screws	32
SLT/TLT rotating nuts	34
Shaft end combinations	36
Standard machined ends	37
Screw shaft accessories	42
Calculation formulae	48
Designation	50
Roller screws and cylinders	51

SKF – the knowledge engineering company

From the company that invented the self-aligning ball bearing more than 100 years ago, SKF has evolved into a knowledge engineering company that is able to draw on five technology platforms to create unique solutions for its customers. These platforms include bearings, bearing units and seals, of course, but extend to other areas including: lubricants and lubrication systems, critical for long bearing life in many applications; mechatronics that combine mechanical and electronics knowledge into systems for more effective linear motion and sensorized solutions; and a full range of services, from design and logistics support to conditioning monitoring and reliability systems.

Though the scope has broadened, SKF continues to maintain the world's leadership in the design, manufacture and marketing of rolling bearings, as well as complementary products such as radial seals. SKF also holds an increasingly important position in the market for linear motion products, high-precision aerospace bearings, machine tool spindles and plant maintenance services.

The SKF Group is globally certified to ISO 14001, the international standard for environmental management, as well as OHSAS 18001, the health and safety management standard. Individual divisions have been approved for quality certification in accordance with ISO 9001 and other customer specific requirements.

With over 100 manufacturing sites worldwide and sales companies in 70 countries, SKF is a truly international corporation. In addition, our distributors and dealers in some 15 000 locations around the world, an e-business marketplace and a global distribution system put SKF close to customers for the supply of both products and services. In essence, SKF solutions are available wherever and whenever customers need them. Overall, the SKF brand and the corporation are stronger than ever. As the knowledge engineering company, we stand ready to serve you with world-class product competencies, intellectual resources, and the vision to help you succeed.



© Airbus – photo: e/m company, H. Goussé

Evolving by-wire technology

SKF has a unique expertise in fast-growing by-wire technology, from fly-by-wire, to drive-by-wire, to work-by-wire. SKF pioneered practical fly-by-wire technology and is a close working partner with all aerospace industry leaders. As an example, virtually all aircraft of the Airbus design use SKF by-wire systems for cockpit flight control.

SKF is also a leader in automotive by-wire technology, and has partnered with automotive engineers to develop two concept cars, which employ SKF mechatronics for steering and braking. Further by-wire development has led SKF to produce an all-electric forklift truck, which uses mechatronics rather than hydraulics for all controls.

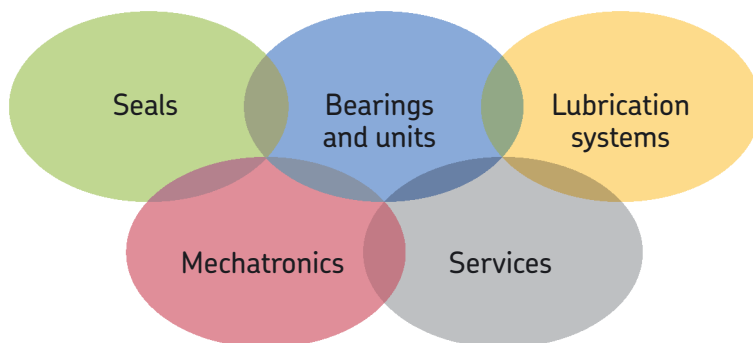



Harnessing wind power

The growing industry of wind-generated electric power provides a source of clean, green electricity. SKF is working closely with global industry leaders to develop efficient and trouble-free turbines, providing a wide range of large, highly specialized bearings and condition monitoring systems to extend equipment life of wind farms located in even the most remote and inhospitable environments.



Working in extreme environments

In frigid winters, especially in northern countries, extreme sub-zero temperatures can cause bearings in railway axleboxes to seize due to lubrication starvation. SKF created a new family of synthetic lubricants formulated to retain their lubrication viscosity even at these extreme temperatures. SKF knowledge enables manufacturers and end user customers to overcome the performance issues resulting from extreme temperatures, whether hot or cold. For example, SKF products are at work in diverse environments such as baking ovens and instant freezing in food processing plants.



Developing a cleaner cleaner

The electric motor and its bearings are the heart of many household appliances. SKF works closely with appliance manufacturers to improve their products' performance, cut costs, reduce weight, and reduce energy consumption. A recent example of this cooperation is a new generation of vacuum cleaners with substantially more suction. SKF knowledge in the area of small bearing technology is also applied to manufacturers of power tools and office equipment.



Maintaining a 350 km/h R&D lab

In addition to SKF's renowned research and development facilities in Europe and the United States, Formula One car racing provides a unique environment for SKF to push the limits of bearing technology. For over 50 years, SKF products, engineering and knowledge have helped make Scuderia Ferrari a formidable force in F1 racing. (The average racing Ferrari utilizes more than 150 SKF components.) Lessons learned here are applied to the products we provide to automakers and the aftermarket worldwide.



Delivering Asset Efficiency Optimization

Through SKF Reliability Systems, SKF provides a comprehensive range of asset efficiency products and services, from condition monitoring hardware and software to maintenance strategies, engineering assistance and machine reliability programmes. To optimize efficiency and boost productivity, some industrial facilities opt for an Integrated Maintenance Solution, in which SKF delivers all services under one fixed-fee, performance-based contract.



Planning for sustainable growth

By their very nature, bearings make a positive contribution to the natural environment, enabling machinery to operate more efficiently, consume less power, and require less lubrication. By raising the performance bar for our own products, SKF is enabling a new generation of high-efficiency products and equipment. With an eye to the future and the world we will leave to our children, the SKF Group policy on environment, health and safety, as well as the manufacturing techniques, are planned and implemented to help protect and preserve the earth's limited natural resources. We remain committed to sustainable, environmentally responsible growth.

Overview ball screw nuts

Screw assembly

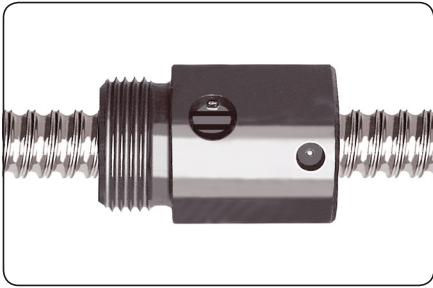

SD/BD
SDS/BDS

Type of recirculation

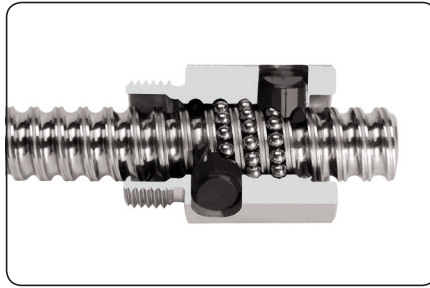

Internal, by inserts
Stainless steel optional ¹⁾

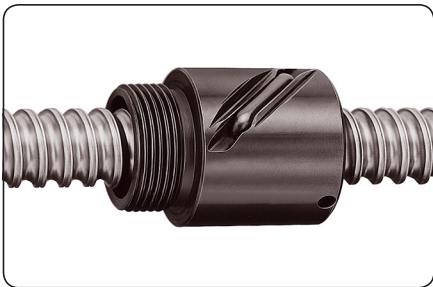

SH
SHS



External, by integrated tube
Stainless steel optional ²⁾



SX/BX

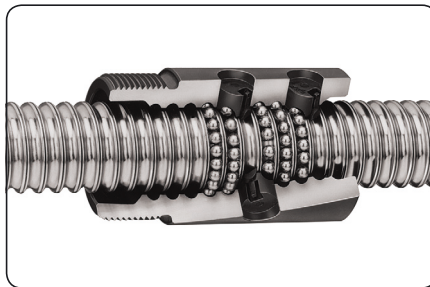

Internal, by inserts

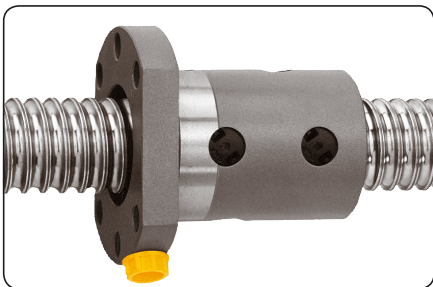

SND/BND/PND

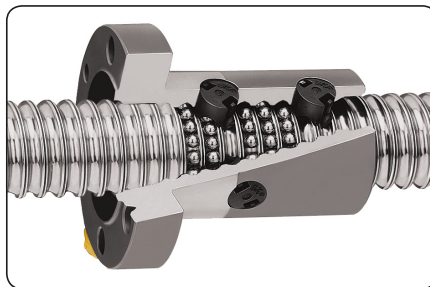

Internal, by inserts, DIN version

Designation	d ₀	P _h	p.
	mm	mm	
SD/BD/SDS/BDS	8	2,5	16
SD/BD/SDS/BDS	10	2	
SD/BD	10	4	18
SD/BD/SDS/BDS	12	2–4–5	
SD/BD/SDS/BDS	14	4	
SD/BD/SDS/BDS	16	2–5	
SD/BD	16	10	
SH/SHS	6	2	16
SH	10	3	
SH	12,7	12,7	
			18
SX/BX	20	5	20
SX/BX	25	5–10	
SX/BX	32	5–10	
SX/BX	40	5–10–40	
SX/BX	50	10	
SX/BX	63	10	
SND/BND/PND	16	5–10	24
SND/BND/PND	20	5	
SND/BND/PND	25	5–10	
SND/BND/PND	32	5–10	
SND/BND/PND	40	5–10	
SND/BND/PND	50	10	
SND/BND/PND	63	10	

¹⁾ except 10×4 and 16×10
²⁾ 6×2 only.

Screw assembly

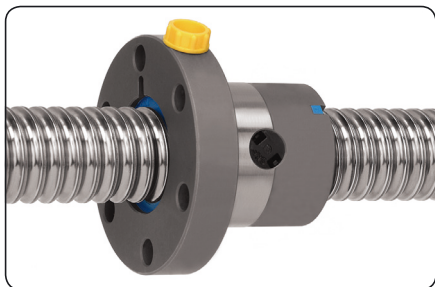

SN/BN/PN

Type of recirculation

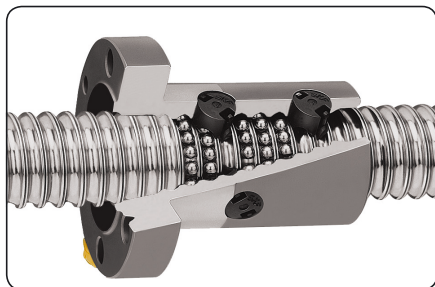

Internal, by inserts

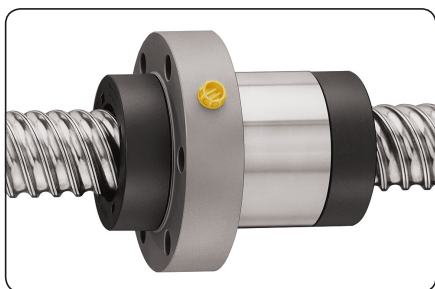

SL/TL – SLD/TLD

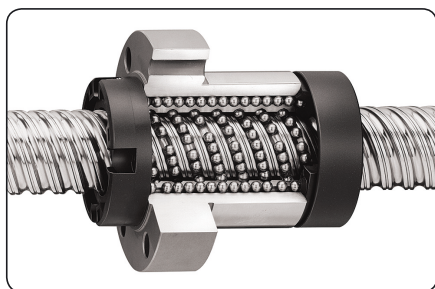

By faces

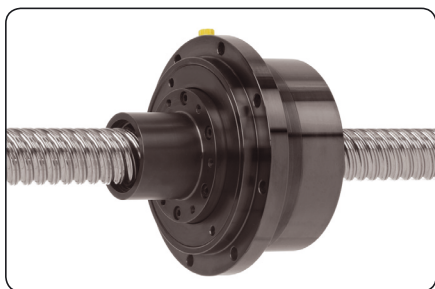

SLT, TLT, Rotating nuts

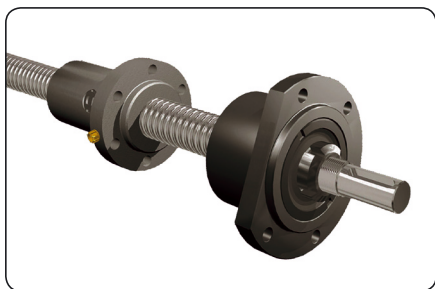

Ends bearings: FLBU, PLBU, BUF

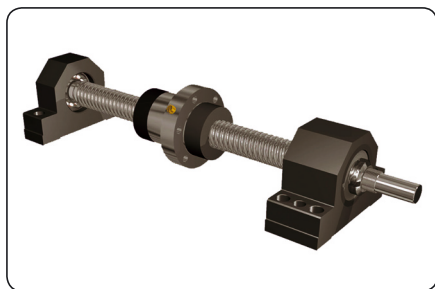

Designation	d ₀	P _h	p.
	mm	mm	
SN/BN/PN	16	5	28
SN/BN/PN	20	5	
SN/BN/PN	25	5–10	
SN/BN/PN	32	5–10	
SN/BN/PN	40	5–10	
SN/BN/PN	50	10	
SN/BN/PN	63	10	
SL/TL	25	20–25	32
SL/TL	32	20–32–40	
SLD/TLD	32	32	
SL/TL	40	20–40	
SL/TL	50	50	
SLT/TLT	25	20–25	34
SLT/TLT	32	20–32–40	
SLT/TLT	40	20–40	
SLT/TLT	50	50	
FLBU/PLBU/BUF	16		44
FLBU/PLBU/BUF	20		
FLBU/PLBU/BUF	25		
FLBU/PLBU/BUF	32		
FLBU/PLBU/BUF	40		
FLBU/PLBU/BUF	50		
FLBU/PLBU/BUF	63		

Basic concepts

Only basic selection parameters are included. To make the very best selection of a ball screw, the designer should specify such critical parameters as the load profile, the linear or rotational speed, the rates of acceleration and deceleration, the cycle rate, the environment, the required life, the lead accuracy, the stiffness, and any other special requirement. If in doubt, please consult an SKF ball screw specialist before placing an order.

Basic dynamic load rating (C_a)

The dynamic rating is used to compute the fatigue life of ball screws. It is the axial load constant in magnitude and direction, and acting centrally under which the nominal life (as defined by ISO) reaches one million revolutions.

Nominal fatigue life L_{10}

The nominal life of a ball screw is the number of revolutions (or the number of operating hours at a given constant speed) which the ball screw is capable of enduring before the first sign of fatigue (flaking, spalling) occurs on one of the rolling surfaces.

It is however evident from both laboratory tests and practical experience that seemingly identical ball screws operating under identical conditions have different lives, hence the notion of nominal life.

It is, in accordance with ISO definition, the life achieved or exceeded by 90 % of a sufficiently large group of apparently identical ball screws, working in identical conditions (alignment, axial and centrally applied load, speed, acceleration, lubrication, temperature and cleanliness).

Service life

The actual life achieved by a specific ball screw before it fails is known as "service life". Failure is not only by fatigue (flaking or spalling); but also by inadequate lubrication and wear; wear of the recirculation system, corrosion, contamination, and, more generally, by loss of the functional characteristics required by the application.

Experience acquired with similar applications will help to select the proper screw to obtain the required service life. One must also take into account structural requirements such as the strength of screw ends and nut attachments, due to the loads applied on these elements in service. To attain L_{10} life performance a mean working load of up to 60 % of C_a and a stroke higher than 4 leads are permitted.

Equivalent dynamic loads

The loads acting on the screw can be calculated according to the laws of mechanics if the external forces (e.g. power transmission, work, rotary and linear inertia forces) are known or can be calculated. It is necessary to calculate the equivalent dynamic load.

Radial and moment loads must be taken by linear bearing systems. It is extremely important to resolve these problems at the earliest conceptual stage. These forces are detrimental to the life and the expected performance of the screw.

Fluctuating load

When the load fluctuates during the working cycle, it is necessary to calculate the equivalent dynamic load: this load is defined as that hypothetical load, constant in magnitude and direction, acting axially and centrally on the screw which, if applied, would have the same influence on the screw life as the actual loads to which the screw is subjected.

Additional loads due, for example to misalignment, uneven loading, shocks, and so on, must be taken into account.

Life test bench



Their influence on the nominal life of the screw is generally taken care of, consult SKF for advice.

Static load carrying capacity (C_{0a})

Ball screws should be selected on the basis of the basic static load rating C_{0a} instead of on bearing life when they are submitted to continuous or intermittent shock loads, while stationary or rotating at very low speed for short duration. The permissible load is determined by the permanent deformation caused by the load acting at the contact points.

It is defined by ISO standards as the purely axially and centrally applied static load which will create, by calculation, a total (rolling element + thread surface) permanent deformation equal to 0,0001 of the diameter of the rolling element (→ fig. 1).

A ball screw must be selected by its basic static load rating which must be, at least, equal to the product of the maximum axial static load applied and a safety factor “ s_0 ”.

The safety factor is selected in relation with past experience of similar applications and requirements of running smoothness and noise level¹⁾.

Critical rotating speed for screw shafts

The shaft is equated to a cylinder, the diameter of which is the root diameter of the thread. The formulae use a parameter the value of which is dictated by the mounting of the screw shaft (whether it is simply supported or fixed).

As a rule the nut is not considered as a support of the screw shaft. Because of the potential inaccuracies in the mounting of the screw assembly, a safety factor of 0,8 is applied to the calculated critical speeds.

Calculations which consider the nut as a support of the shaft, or reduce the safety factor, require practical tests and possibly an optimization of the design.

Permissible speed limit

The permissible speed limit is that speed which a screw cannot reliably exceed at any

time. It is generally the limiting speed of the recirculation system in the nut. It is expressed as the product of the rpm and the nominal diameter of the screw shaft (in mm).

The speed limits quoted in this catalogue are the maximum speeds that may be applied through very short periods and in optimized running conditions of alignment, light external load and preload with monitored lubrication.

Running a screw continuously at the permissible speed limit may lead to a reduction of the calculated life of the nut mechanism.

Careful

High speed associated with high load requires a large input torque and yields a relatively short nominal life¹⁾.

In the case of high acceleration and deceleration, it is recommended to either work under a nominal external load or to apply a light preload to the nut to avoid internal sliding during reversal.

The value of preload of screws submitted to high velocity must be that preload which ensures that the rolling elements do not slide ¹⁾.

Too high a preload will create unacceptable increases of the internal temperature.

Lubrication

The lubrication of screws rotating at high speed must be properly considered in quantity and quality.

The volume, spread and frequency of the application of the lubricant (oil or grease) must be properly selected and monitored. At high speed the lubricant spread on the surface of the screw shaft may be thrown off by centrifugal forces. It is important to monitor this phenomenon during the first run at high speed and possibly adapt the frequency of relubrication or the flow of lubricant, or select a lubricant with a different viscosity.

Monitoring the steady temperature reached by the nut permits the frequency of relubrication or the oil flow rate to be optimized.

Efficiency and back-driving

The performance of a screw is mainly dependant on the geometry of the contact surfaces and their finish as well as the helix angle of the thread. It is, also, dependant on the working conditions of the screw (load,

speed, lubrication, preload, alignment, etc ...).

The “direct efficiency” is used to define the input torque required to transform the rotation of one member into the translation of the other. Conversely, the “indirect efficiency” is used to define the axial load required to transform the translation of one member into the rotation of the other one. It is used, also, to define the braking torque required to prevent that rotation.

It is safe to consider that these screws are reversible or back-driveable under almost all circumstances.

It is therefore necessary to design a brake mechanism if backdriving is to be avoided (gear reducers or brake).

Preload torque:

Internally preloaded screws exhibit a torque due to this preload. This persists even when they are not externally loaded. Preload torque is measured when assembly is lubricated with ISO grade 64 oil.

Starting torque:

This is defined as the torque needed to overcome the following to start rotation:

- a the total inertia of all moving parts accelerated by the energy source (including rotation and linear movement).
- b the internal friction of the screw/nut assembly, bearing and associated guiding devices.

In general, torque to overcome inertia (a) is greater than friction torque (b).

The coefficient of friction of the high efficiency screw when starting μ_s is estimated at up to double the dynamic coefficient μ , under normal conditions of use.

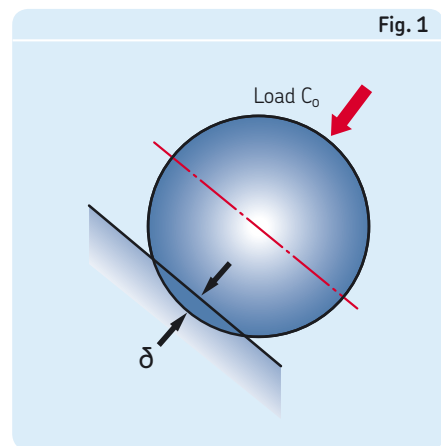

Fig. 1

¹⁾ SKF can help you to define this value in relation with the actual conditions of service.

Axial play and preload

SKF products are available with different versions of axial play. Standard axial play is intended for transport screws, where product is not submitted to vibrations, high accelerations, and where accuracy under load is not critical (ex: SN type).

Reduced play (ex: SN type with reduced play) and backlash elimination by oversize balls (ex: BN type) are proposed to increase assembly precision (→ fig. 2).

For optimum rigidity, internal preloaded nuts are recommended (ex: PN type), (→ fig. 3). Indeed preloaded nuts are subject to much less elastic deformation than non-preloaded nuts. Therefore they should be used whenever the accuracy of positioning under load is important.

Preload is that force applied to a set of two half nuts to either press them together or push them apart with the purpose of eliminating backlash or increasing the rigidity or stiffness of the assembly. The preload is defined by the value of the preload torque (see under that heading in the previous paragraph). The torque depends on the type of nut and on the mode of preload (elastic or rigid).

Static axial stiffness of a complete assembly

It is the ratio of the external axial load applied on the system and the axial displacement of the face of the nut in relation with the fixed (anchored) end of the screw shaft. The inverse of the rigidity of the total system is equal to the sum of all the inverses of the rigidity of each of the components (screw shaft, nut as mounted on the shaft, supporting bearing, supporting housings, etc...).

$$\frac{1}{R_t} = \frac{1}{R_s} + \frac{1}{R_n} + \frac{1}{R_p}$$

Because of this, the rigidity of the total system is always less than the smallest individual rigidity.

Nut rigidity: R_n

When a preload is applied to a split nut, firstly, the internal play is eliminated, then, the Hertzian elastic deformation increases as the preload applied so that the overall rigidity increases.

The theoretical deformation does not take into account machining inaccuracies, actual sharing of the load between the different contact surfaces, the elasticity of the nut and of the screw shaft.

The practical stiffness values given in the catalogue are lower than the theoretical values for this reason.

They are determined by SKF based on the value of the selected basic preload and an external load equal to twice this preload.

Shaft rigidity: R_s

The elastic deformation of screw shaft is proportional to its length and inversely proportional to the square of the root diameter.

According to the relative importance of the screw deformation (see rigidity of the total system), too large an increase in the preload of the nut and supporting bearings yields a limited increase of rigidity and notably increases the preload torque and therefore the running temperature.

Consequently, the preload stated in the catalogue for each dimension is optimum and should not be increased.

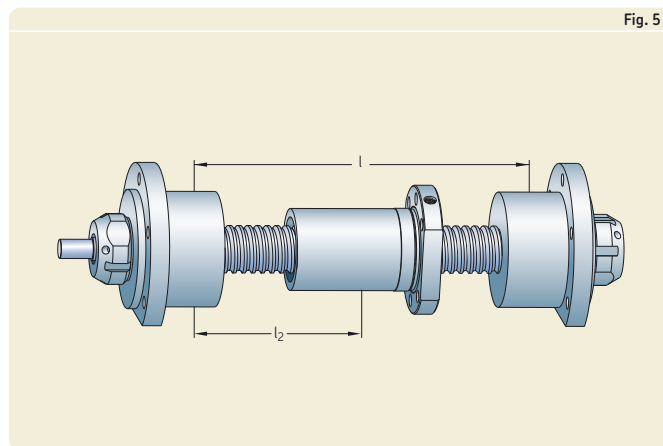
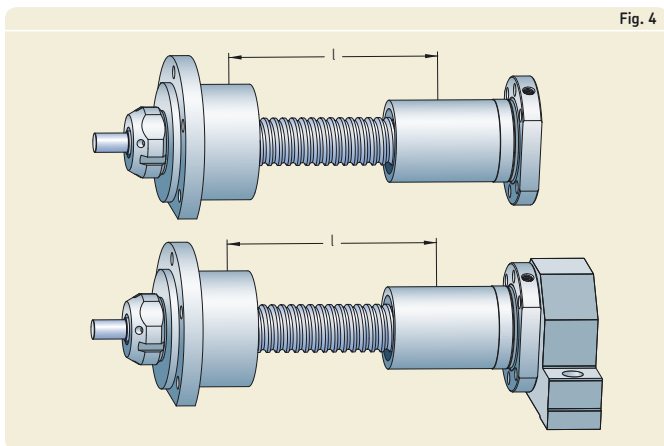
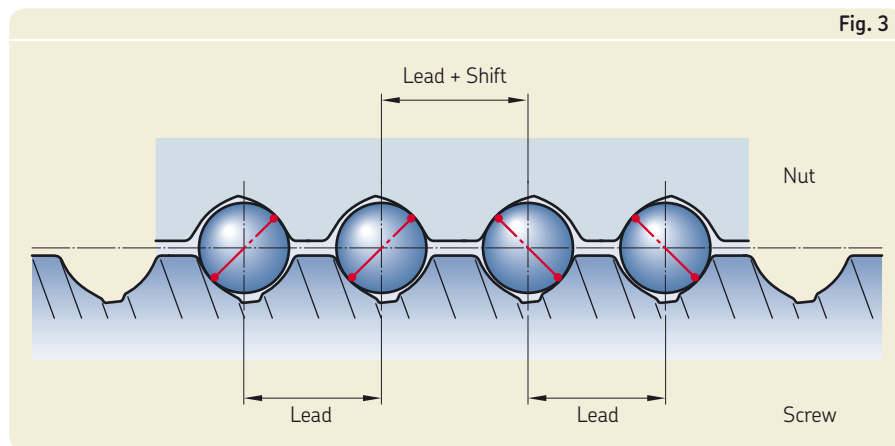
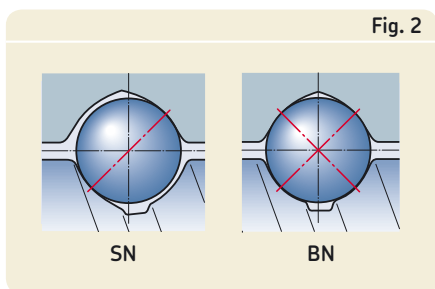

Fix-free or fix-support

$$R_s = 165 \frac{d_2^2}{l} \quad (\rightarrow \text{fig. 4})$$

Fix-fix assembly

$$R_s = \frac{165 d_2^2 l}{l_2 (l - l_2)} \quad (\rightarrow \text{fig. 5})$$

Where

R_s = Shaft rigidity [N/μm]

For d_2 values, please refer to product pages.

Screw shaft buckling

The column loading of the screw shaft must be checked when it is submitted to compression loading (whether dynamically or statically).

The maximum permissible compressive load is calculated using the Euler formulae. It is then multiplied by a safety factor of 3 to 5, depending on the application.

The type of end mounting of the shaft is critical to select the proper coefficients to be used in the Euler formulae.

When the screw shaft comprises a single diameter, the root diameter is used for the calculation. When the screw comprises different sections with various diameters, calculations becomes more complex ¹⁾.

¹⁾ SKF can help you to define this value in relation with the actual conditions of service.

Manufacturing precision

Generally speaking, the precision indication given in the designation defines the lead precisions (→ **page 14**) – (e.g. G5–G7...).

Parameters other than lead precision correspond to our internal standards (generally based on ISO “class 7”).

If you require special tolerances (for example class 5) please specify when requesting a quotation or ordering.

High precision rolled screws

The combination of Hightech machines and the control of the cold forming and metallurgical processes result in a screw that has virtually the same accuracy and performance of a ground unit at a lower cost (→ **diagram 1**).

Materials and heat treatments

Standard screw shafts are machined from carbon steel which is surface hardened by induction.

Standard nuts are machined in steel which is through hardened (100 Cr6–NFA 35.565 or equivalent for diameters ≥ 20 mm and carbon steel for diameters < 20 mm). Hardness of the contact surfaces is 56–60 HRc, depending on diameter, for standard screws.

Most assemblies made of stainless material have a surface hardness in the range 50 to 58 HRc, depending on the type. The load rating of the catalogue are given only for standard screws.

Number of circuits of balls

A nut is defined by the number of ball turns which support the load.

The number is changing, according to the product and the combination diameter/lead.

It is defined by the number of circuits and their type.

Recirculation inserts

The standard products have been fitted with composite ball recirculation inserts.

System performance is improved because of the smoother ball recirculation. This results from the improved precision of the moulded insert when compared to the steel insert. If the product is used in severe applications, or the insert is used to prevent collapse (especially in vertical applications), a steel version is available. In such cases, the specifier should consult SKF to obtain the optimum solution.

Working environment

Our products have not been developed for use in an explosive atmosphere, consequently we cannot take any responsibility for the use in this field.

Diagram 1

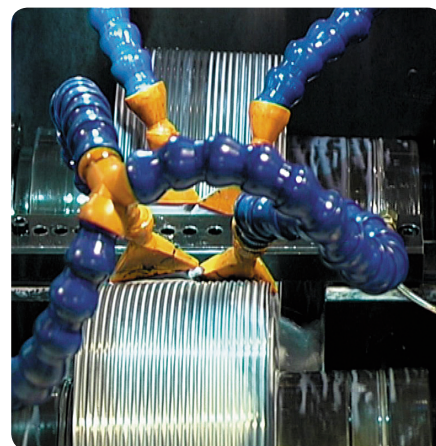
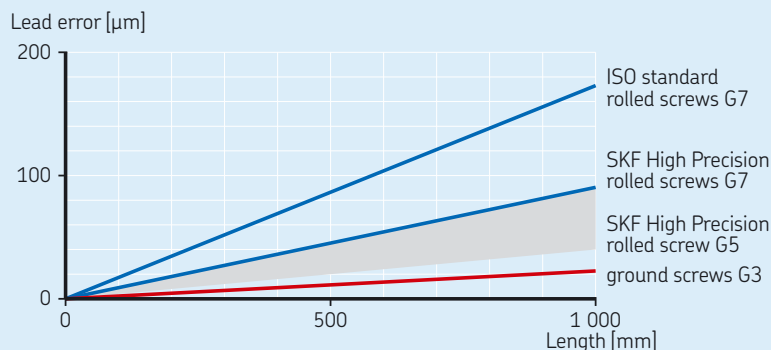

Assembly procedure

Ball screws are precision components and should be handled with care to avoid shocks. When stored out of the shipping crate they must lie on wooden or plastic vee blocks and should not be allowed to sag. Screw assemblies are shipped, wrapped in a heavy gauge plastic tube which protects them from foreign material and possible pollution. They should stay wrapped until they are used.

Radial and moment loads

Any radial or moment load on the nut will overload some of the contact surfaces, thus significantly reducing life (→ fig. 6).

Alignment

SKF linear guidance components should be used to ensure correct alignment and avoid non-axial loading. The parallelism of the screw shaft with the guiding devices must be checked. If external linear guidance proves impractical, we suggest mounting the nut on trunnions or gimbals and the screw shaft in self-aligning bearings.

Mounting the screw in tension helps align it properly and eliminates buckling.

Lubrication

Good lubrication is essential for the proper functioning of the screw and for its long term reliability¹.

Before shipping, the screw is coated with a protective fluid that dries to a film. This protective film is not a lubricant.

Depending on the selected lubricant, it may be necessary to remove this film before applying the lubricant (there may be a risk of non-compatibility).

If this operation is performed in a potentially polluted atmosphere it is highly recommended to proceed with a thorough cleaning of the assembly.

Designing the screw shaft ends

Generally speaking, when the ends of the screw shaft are specified by the customer's engineering personnel, it is their responsibility to check the strength of these ends. However, we offer in pages 36 to 41 of this catalogue, a choice of standard machined ends. As far as possible, we recommend their use.

Whatever your choice may be, please keep in mind that no dimension on the shaft ends can exceed d_0 (otherwise traces of the root of thread will appear or the shaft must be made by joining 2 pieces).

A minimum shoulder should be sufficient to maintain the inner bearing ring.

Operating temperature

Screws made from standard steel (→ page 11) and operating under normal loads can sustain temperatures in the range -20 to +110 °C.

Between 110 and 130 °C, SKF must be notified so that it adapts the annealing procedure and checks that the application can be successful with a hardness below the standard minimum value (→ page 11).

Above 130 °C, steels adapted to the temperature of the application should be selected (100Cr6, special steel, etc...). Consult SKF for advice.

Operating at high temperature will lower the hardness of the steel, alter the accuracy of the thread and may increase the oxidability of the materials or change lubricant properties.

Fig. 6

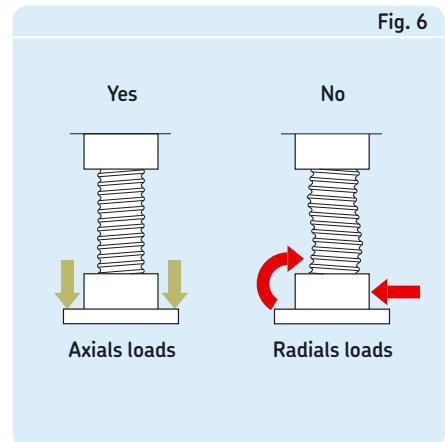

¹) SKF can help you to define this value in relation with the actual conditions of service.

Separating the nut from the screw shaft

Never screw the nut off the shaft without a mandrel to prevent the balls coming out (→ fig. 7).

- 1 Remove the retaining strap
- 2 Hold the sleeve against the ball track). If the sleeve does not go over the diameter next to the ball track, adhesive tape can be used or the sleeve held against the unmachined end (→ fig. 8)
- 3 Without forcing, engage the nut in the screw thread.

Starting-up the screw

After the assembly has been cleaned, mounted and lubricated, it is recommended that the nut is allowed to make several full strokes at low speed; to check the proper positioning of the limit switches or reversing mechanism before applying the full load and the full speed.

Note:

Instructions for most operations like mounting a nut on a screw shaft, a wiper on a nut, etc... are available in separate sheets delivered with the product: please refer to them

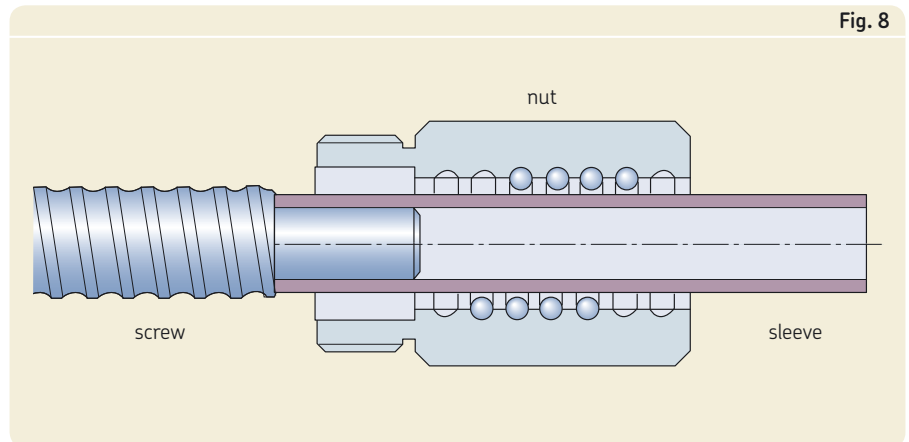
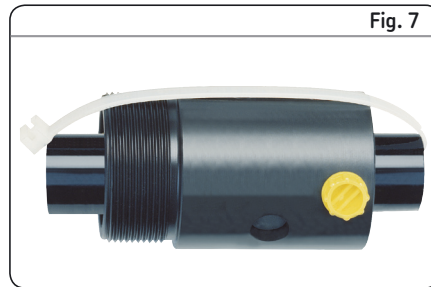

Technical data

Lead precision

Lead precision is measured at 20 °C on the useful stroke l_u , which is the threaded length decreased, at each end, by the length l_e equal to the screw shaft diameter (→ **table 2 and fig. 8**).

Case with value of c specified by the customer (→ **fig. 9**).

Case with $c = 0$ = standard version in case of no value given by the customer (→ **fig. 10**).

Table 2

V_{300p} l_u	G5		G7		G9	
	e_p	v_{up}	e_p	v_{up}	e_p	v_{up}
mm	μm					
0 – 315	23	23	52	35	130	87
(315) – 400	25	25	57	40	140	100
(400) – 500	27	26	63	46	155	115
(500) – 630	32	29	70	52	175	130
(630) – 800	36	31	80	57	200	140
(800) – 1 000	40	34	90	63	230	155
(1 000) – 1 250	47	39	105	70	260	175
(1 250) – 1 600	55	44	125	80	310	200
(1 600) – 2 000	65	51	150	90	370	230
(2 000) – 2 500	78	59	175	105	440	260
(2 500) – 3 150	96	69	210	125	530	310
(3 150) – 4 000	115	82	260	150	640	370
(4 000) – 5 000	140	99	320	175	790	440
(5 000) – 6 000	170	119	390	210	960	530

Lead accuracy control on a complete assembly

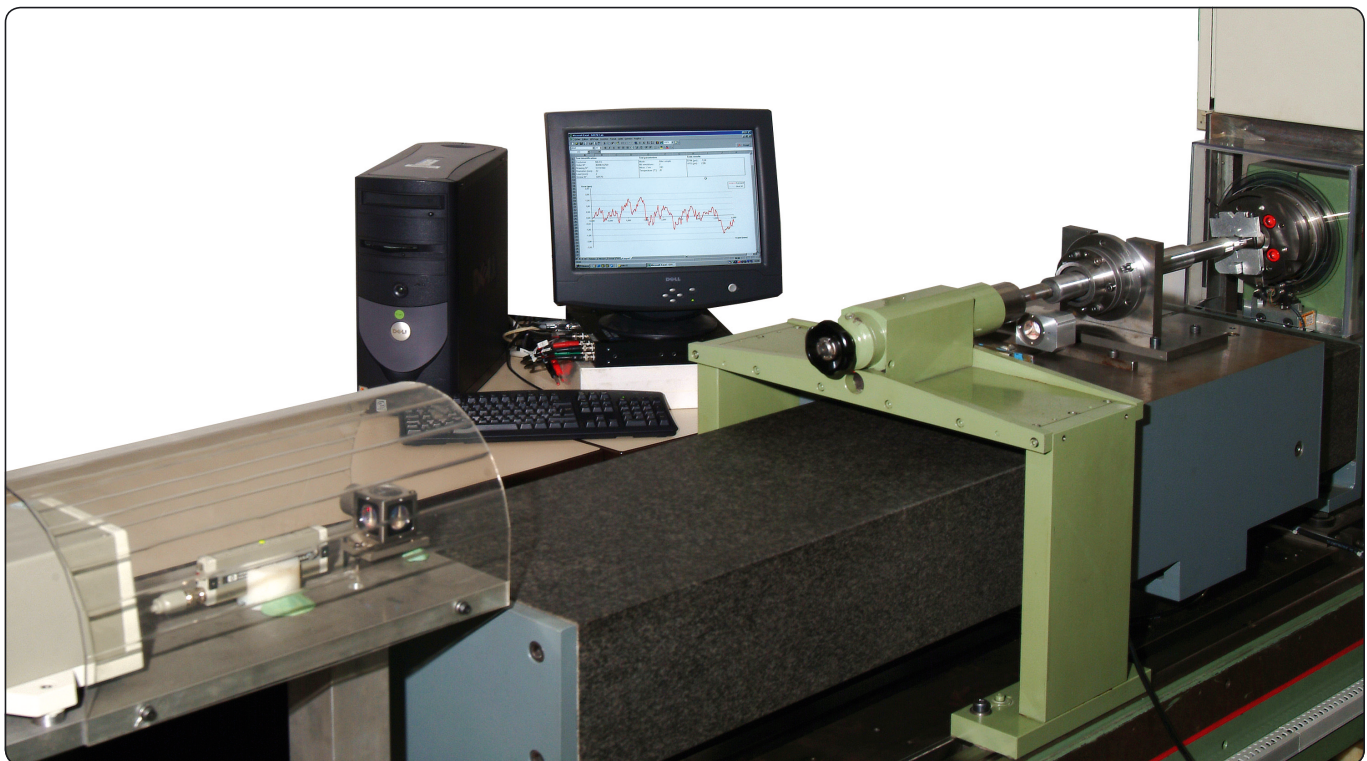

Symbols used in figs. 8 to 10

- l_u = useful travel
- l_e = excess travel (no lead precision required)
- l_o = nominal travel
- l_s = specified travel
- c = travel compensation (difference between l_s and l_o to be defined by the customer, for instance to compensate an expansion)
- e_p = tolerance over the specified travel
- V = travel variation (or permissible band width)
- V_{300p} = maximum permitted travel variation over 300 mm
- V_{up} = maximum permitted travel variation over the useful travel l_u
- V_{300a} = measured travel variation over 300 mm
- V_{ua} = measured travel variation over the useful travel

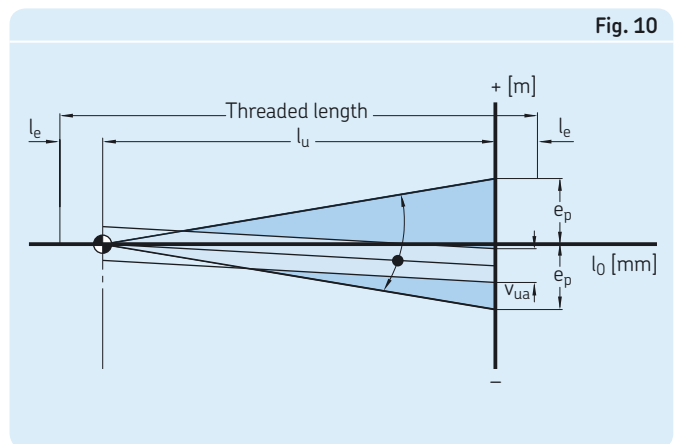
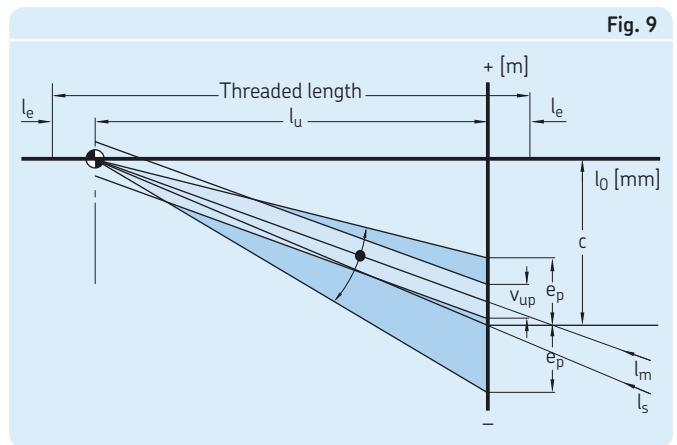
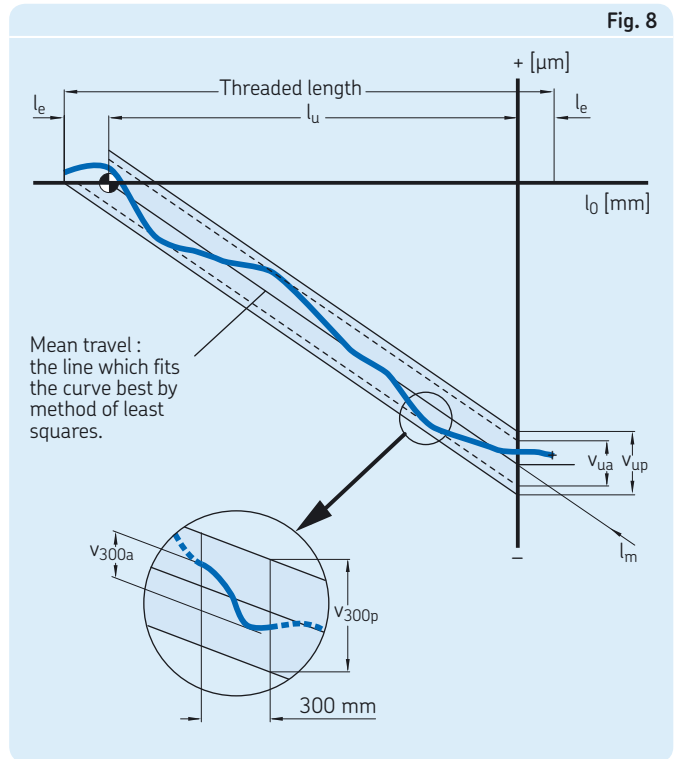

SD/BD/SH miniature screws

Rolled thread miniature ball screw, nut with threaded end.

- Nominal diameter: 6 to 16 mm
- Lead: 2 to 12,7 mm
- Cylindrical nut with threaded end: easy mounting
- Excellent repeatability: high positioning quality
- Recirculation with inserts: (SD/BD) or tube (SH) smooth running and good backdriving
- Backlash elimination by oversize balls on request (only for insert design BD).
Maximum length 1 000 mm
- Optional safety device*):
12×4R – 14×4R – 16×5R – 12,7×12,7R
- Optional wipers*): For all sizes except
6×2R – 10×3R.

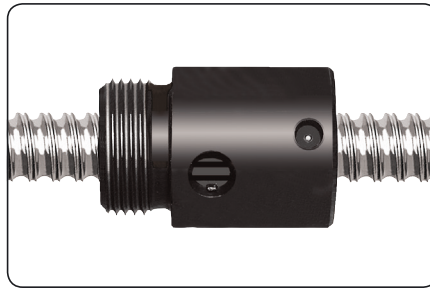

Standard SD

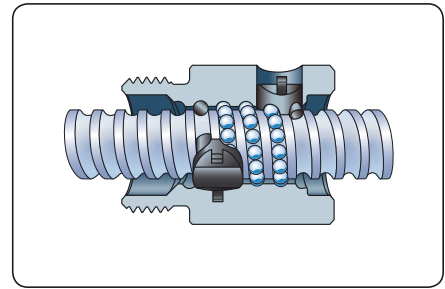

Recirculation SD

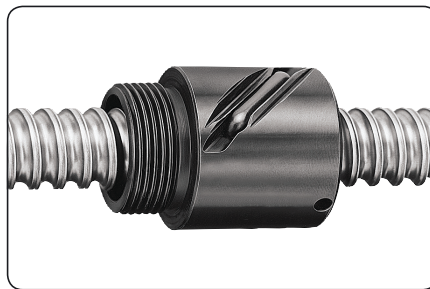

Standard SH



Customised SD

Nominal diameter	Lead (right hand)	Nut		Number of circuits of balls	Max play	Reduced play on request	Inertia	Grease	Weight	Screw			Designation
		Basic load ratings dynamic	static							Mass	Inertia	Grease	
d_0	P_h	C_a	C_{oa}		mm		kgmm^2	cm^3	kg	kg/m	kgmm^2/m	cm^3/m	–
mm	mm	kN		–	mm		kgmm^2	cm^3	kg	kg/m	kgmm^2/m	cm^3/m	–
6	2	1,2	1,5	1×2,5	0,05	0,02	7,7	0,1	0,025	0,18	0,7	0,7	SH 6×2 R
8	2,5	2,2	2,6	3	0,07	0,03	1,12	0,1	0,025	0,32	2,1	1,1	SD/BD 8×2,5 R
10	2	2,5	3,5	3	0,07	0,03	1,7	0,1	0,03	0,51	5,2	1,4	SD/BD 10×2 R
	3	2,3	3,5	1×2,5	0,07	0,03	2,9	0,3	0,05	0,5	5,1	1,3	SH 10×3 R
	4	4,5	5,4	3	0,07	0,03	2,7	0,3	0,04	0,43	3,8	1,3	SD/BD 10×4 R
12	2	2,9	4,6	3	0,07	0,03	1,5	0,1	0,023	0,67	10	1,7	SD/BD 12×2 R
	4	5	6,5	3	0,07	0,03	7	0,4	0,066	0,71	10,8	1,6	SD/BD 12×4 R
	5	4,2	5,3	3	0,07	0,03	5	0,6	0,058	0,71	10,1	1,4	SD/BD 12×5 R
12,7	12,7	5,3	9	2×1,5	0,07	0,03	20	1,1	0,15	0,71	16,2	1,6	SH 12,7×12,7 R
14	4	6	9	3	0,07	0,03	8	0,6	0,083	1,05	22	1,7	SD/BD 14×4 R
16	2	3,3	6,2	3	0,07	0,03	9,2	0,6	0,1	1,4	39,7	1,7	SD/BD 16×2 R
	5	7,6	10,5	3	0,07	0,03	22,7	0,9	0,135	1,3	33,9	2,1	SD/BD 16×5 R
	10	10,7	17	2×1,8	0,07	0,03	24,4	1	0,16	1,21	30,7	1,9	SD/BD 16×10 R

* It is not possible to supply safety device and wipers in the same nut.

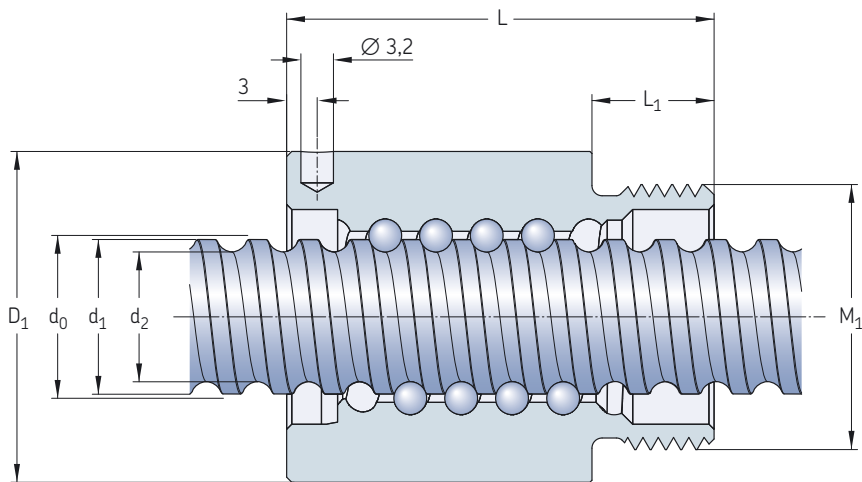

Screw $d_0 \times P_h$ mm	Nut		Without wiper L $\pm 0,3$ mm	With wiper L ₁ mm	Tightening spanner (FACOM)	Screw length max. mm	d ₂ mm	d ₁ mm	Support bearing Recommended thrust bearing type	Recommended support bearing type	
	D ₁ h10 mm	M ₁ 6g mm									
6×2	16,5	M14×1	20	–	7,5	126-A35	1 000	4,7	6		
8×2,5	17,5	M15×1	23,5	23,5	7,5	126-A35	1 000	6,3	7,6		
10×2	19,5	M17×1	22	22	7,5	126-A35	1 000	8,3	9,5		
10×3	21	M18×1	29	–	9	126-A35	1 000	7,9	9,9		
10×4	21	M18×1	28	33	8	126-A35	1 000	7,4	8,9		
12×2	20	M18×1	20	23,5	8	126-A35	2 000	9,9	11,2		
12×4	25,5	M20×1	34	34	10	126-A35	2 000	9,4	11,3		
12×5	23	M20×1	36	40	10	126-A35	2 000	9,3	11,8		
12,7×12,7	29,5	M25×1,5	50	50	12	126-A35	2 000	10,2	13		
14×4	27	M22×1,5	30	34	8	126-A35	2 000	11,9	13,7		
16×2	29,5	M25×1,5	27	27	12	126-A35	2 000	14,3	15,5	FLBU 16/PLBU 16	BUF 16
16×5	32,5	M26×1,5	42	42	12	126-A35	2 000	12,7	15,2	FLBU 16/PLBU 16	BUF 16
16×10	32	M26×1,5	46	46	12	126-A35	2 000	12,6	15,2	FLBU 16/PLBU 16	BUF 16

SDS/BDS/SHS miniature screws in stainless steel

- Nominal diameter: 6 to 16 mm
- Lead: 2 to 5 mm
- Cylindrical nut with threaded end: easy mounting
- Excellent repeatability: high positioning quality
- Backlash elimination by oversize balls on request (BDS designation): maximum length 1 000 mm
- Optional wipers: for all sizes except SHS 6x2R
- Material for both shaft and nut: X30Cr13 (AISI 420 equivalent)
- Balls are in X105CrMo17 (AISI 440C equivalent) except for size 16x5R (SDS/BDS): balls are in 100 Cr6 (AISI 52100 equivalent).

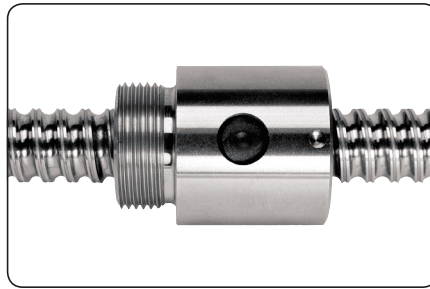

Standard SDS

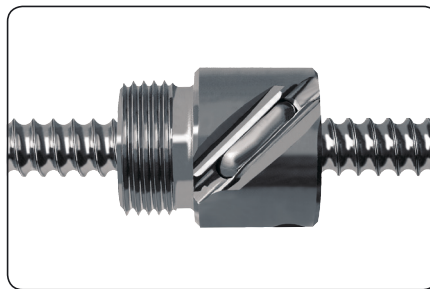
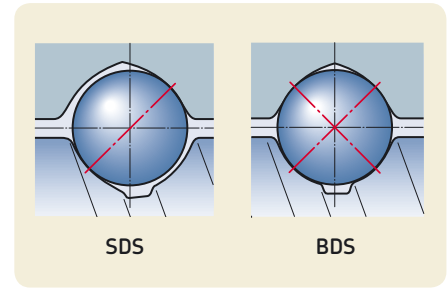

Standard SHS

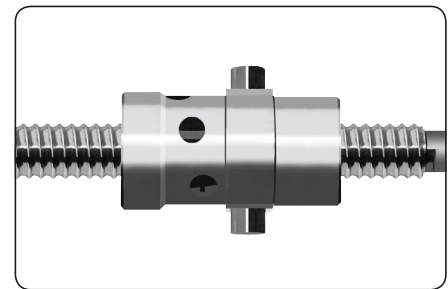

Customised SDS

Nominal diameter	Lead (right hand)	Nut		Number of circuits of balls	Max play	Reduced play on request	Inertia	Grease	Weight	Screw			Designation
		Basic load ratings dynamic	static							Mass	Inertia	Grease	
d_0	P_h	C_a	C_{oa}		mm	mm	kgmm ²	cm ³	kg	kg/m	kgmm ² /m	cm ³ /m	
mm	mm	kN	kN	–	mm	mm	kgmm ²	cm ³	kg	kg/m	kgmm ² /m	cm ³ /m	–
6	2	1	1,1	1x2,5	0,05	0,02	7,7	0,1	0,025	0,18	0,7	0,7	SHS 6x2 R
8	2,5	1,2	1,3	3	0,07	0,03	1,12	0,1	0,025	0,32	2,1	1,1	SDS/BDS 8x2,5 R
10	2	1,6	1,7	3	0,07	0,03	1,7	0,1	0,03	0,51	5,2	1,4	SDS/BDS 10x2 R
12	2	1,8	2,2	3	0,07	0,03	1,5	0,1	0,023	0,67	10	1,7	SDS/BDS 12x2 R
	4	3	3,2	3	0,07	0,03	7	0,4	0,066	0,71	10,8	1,6	SDS/BDS 12x4 R
	5	2,5	2,6	3	0,07	0,03	5	0,6	0,058	0,71	10,1	1,4	SDS/BDS 12x5 R
14	4	3,7	4,4	3	0,07	0,03	8	0,6	0,083	1,05	22	1,7	SDS/BDS 14x4 R
16	2	2	3	3	0,07	0,03	9,2	0,6	0,1	1,4	39,7	1,7	SDS/BDS 16x2 R
	5	4,7	5,1	3	0,07	0,03	22,7	0,9	0,135	1,3	33,9	2,1	SDS/BDS 16x5 R

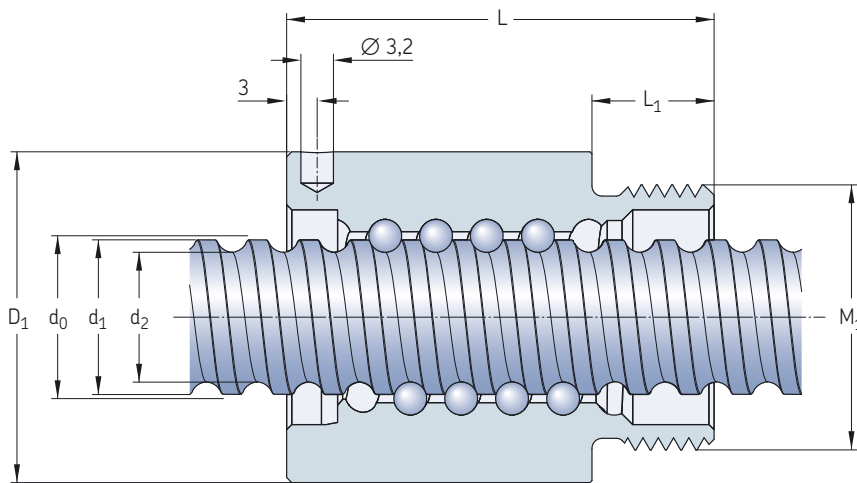

Screw	Nut		Without wiper L ±0,3	With wiper L ₁	Tightening spanner (FACOM)	Screw length max.	d ₂	d ₁	Support bearing Recommended thrust bearing type	Recommended support bearing type	
	D ₁ h10	M ₁ 6g									
d ₀ × P _h	mm	mm	mm	mm	–	mm	mm	mm	–	–	
6×2	16,5	M14×1	20	–	7,5	126-A35	1 000	4,7	6		
8×2,5	17,5	M15×1	23,5	23,5	7,5	126-A35	1 000	6,3	7,6		
10×2	19,5	M17×1	22	22	7,5	126-A35	1 000	8,3	9,5		
12×2	20	M18×1	23,5	23,5	8	126-A35	2 000	9,9	11,2		
12×4	25,5	M20×1	34	34	10	126-A35	2 000	9,4	11,3		
12×5	23	M20×1	40	40	10	126-A35	2 000	9,3	11,8		
14×4	27	M22×1,5	34	34	8	126-A35	2 000	11,9	13,7		
16×2	29,5	M25×1,5	27	27	12	126-A35	2 000	14,3	15,5	FLBU 16/PLBU 16	BUF 16
16×5	32,5	M26×1,5	42	42	12	126-A35	2 000	12,7	15,2	FLBU 16/PLBU 16	BUF 16

SX/BX universal screws

Rolled thread ball screw internal recirculation nut with threaded end.

Standard version: composite inserts.

Special version: steel inserts which can act as a safety device for severe requirements or vertical applications. Contact us.

- Nominal diameter: 20 to 63 mm
- Lead: 5 to 40 mm
- Cylindrical body of minimum diameter to simplify assembly
- Lubrication hole for nipple or automatic SKF SYSTEM 24, positioned relative to the ISO thread
- Handling screw: nut with axial play
- Screw shaft can be phosphated on request
- Wipers available
- Backlash elimination by oversize balls on request (BX designation)
- Nut mounting flanges available
- Screw shaft accessories: FLBU–PLBU and BUF off the shelves (→ pages 42 to 47).



Standard

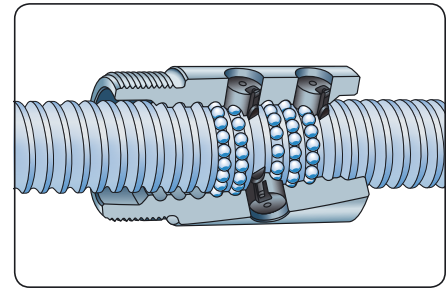

Recirculation

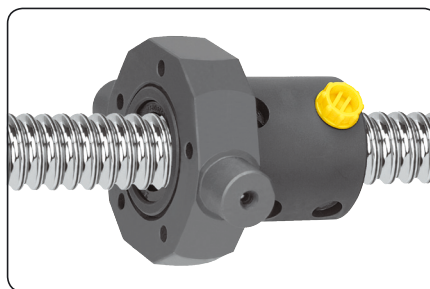

Customised

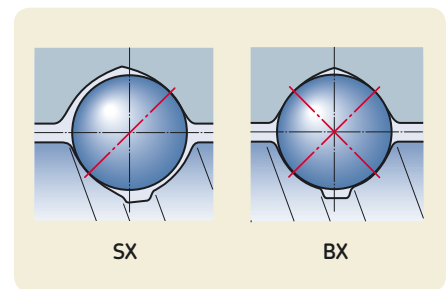

SX

BX

Nominal diameter	Lead (right hand)	Nut		Number of circuits of balls	Max play	Reduced play on request	Preload torque zero play T_{pr}	Inertia	Grease	Weight	Screw		Designation	
		Basic load ratings dynamic	static								Mass	Inertia		Grease
d_0	P_h	C_a	C_{oa}		mm		Nm	kgmm ²	cm ³	kg	kg/m	kgmm ² /m	cm ³ /m	–
mm	mm	kN	–	–	mm		Nm	kgmm ²	cm ³	kg	kg/m	kgmm ² /m	cm ³ /m	–
20	5	14,5	24,4	4	0,1	0,05	0,1	60	1,3	0,24	2	85	2,7	SX/BX 20×5 R
25	5	19,4	37,8	5	0,1	0,05	0,17	125	2,5	0,39	3,3	224	3,4	SX/BX 25×5 R
	10	25,8	43,7	4	0,12	0,08	0,23	135	4,6	0,4	3,2	255	3,2	SX/BX 25×10 R
32	5	22,1	50,5	5	0,1	0,05	0,25	230	2,6	0,48	5,6	641	4,4	SX/BX 32×5 R
	10	28,9	55,7	4	0,12	0,08	0,32	400	5,9	0,77	5,6	639	3,7	SX/BX 32×10 R
40	5	24,1	63,2	5	0,1	0,05	0,34	390	3,3	0,58	9	1 639	5,6	SX/BX 40×5 R
	10	63,6	127,1	5	0,12	0,08	0,64	840	12,4	1,25	8,4	1 437	5	SX/BX 40×10 R
	40	25,1	72,9	2	0,1	0,05	0,64	1 200	14,4	1,6	8,1	1 330	5,2	SX/BX 40×40 R
50	10	81,9	189,1	6	0,12	0,08	1,02	2 400	19,9	2,4	13,6	3 736	6,3	SX/BX 50×10 R
63	10	91,7	243,5	6	0,12	0,08	1,44	4 620	25,4	3,1	22	9 913	8,1	SX/BX 63×10 R

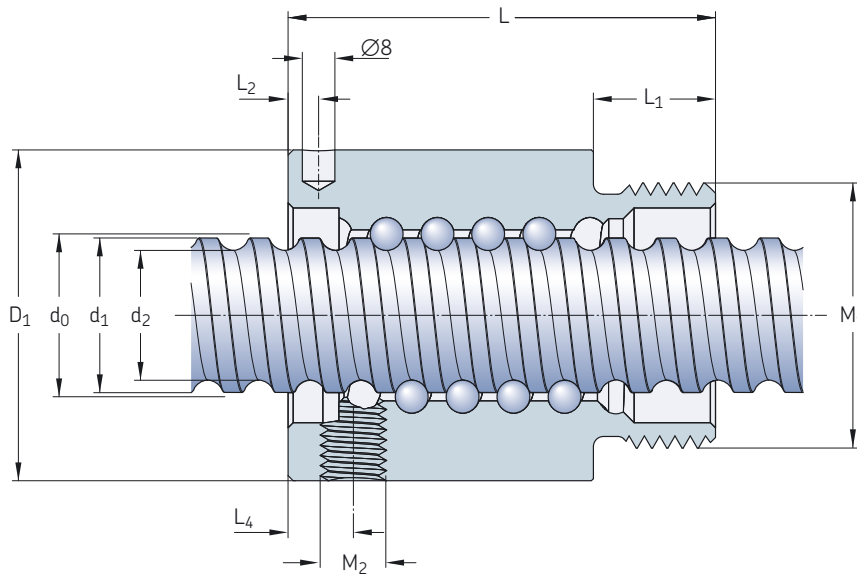

Screw $d_0 \times P_h$ mm	Nut D_1 $js13$ mm	M_1 6g	L	L_1	L_2	L_4	M2	Tightening spanner	Screw length max. mm	d_2	d_1	Support bearing Recommended thrust bearing type	Recommended support bearing type
20×5	38	M35×1,5	54	14	8	8	M6×1	HN5	4 700	16,7	19,4	PLBU 20/FLBU 20 ¹⁾	BUF 20
25×5	43	M40×1,5	69	19	8	8	M6×1	HN6	4 700	21,7	24,6	PLBU 25/FLBU 25	BUF 25
25×10	43	M40×1,5	84	19	12	12	M6×1	HN6	4 700	20,5	24,6	PLBU 25/FLBU 25	BUF 25
32×5	52	M48×1,5	64	19	8	8	M6×1	HN7	5 700	28,7	31,6	PLBU 32/FLBU 32	BUF 32
32×10	54	M48×1,5	95	19	15	15	M6×1	HN7	5 700	27,8	32	PLBU 32/FLBU 32/FLRBU 3 ²⁾	BUF 32
40×5	60	M56×1,5	65	19	8	8	M6×1	HN9	5 700	36,7	39,6	PLBU 40/FLBU 40	BUF 40
40×10	65	M60×2	105	24	15	13	M8×1	HN9	5 700	34	39,4	PLBU 40/FLBU 40/FLRBU 4 ²⁾	BUF 40
40×40	65	M60×2	121	24	20	48,6	M8×1	HN9	5 700	34,2	38,3	PLBU 40/FLBU 40	BUF 40
50×10	78	M72×2	135	29	15	15	M8×1	HN12	5 700	44	49,7	PLBU 50/FLBU 50/FLRBU 5 ²⁾	BUF 50
63×10	93	M85×2	135	29	15	15	M8×1	HN14	5 700	57	62,8	PLBU 63/FLBU 63	BUF 63

¹⁾ for high load application, please contact SKF.

²⁾ for high load application use FLRBU type, please refer to roller screws catalogue for end shaft and support bearing definitions.

Accessories for SX/BX nuts

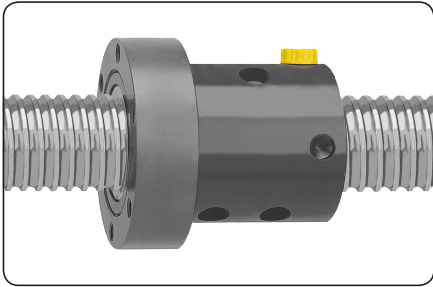

SX nut with round flange (FHRF)

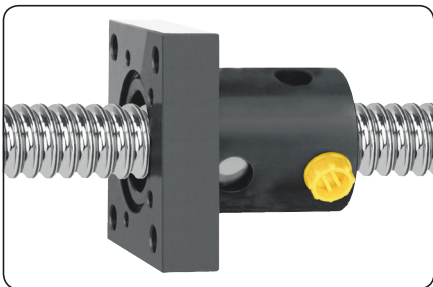
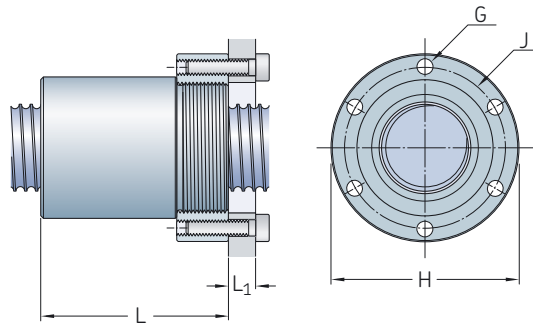

SX nut with square flange (FHSF)

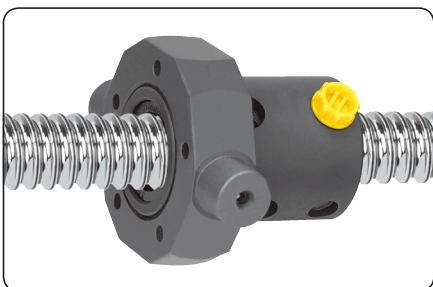
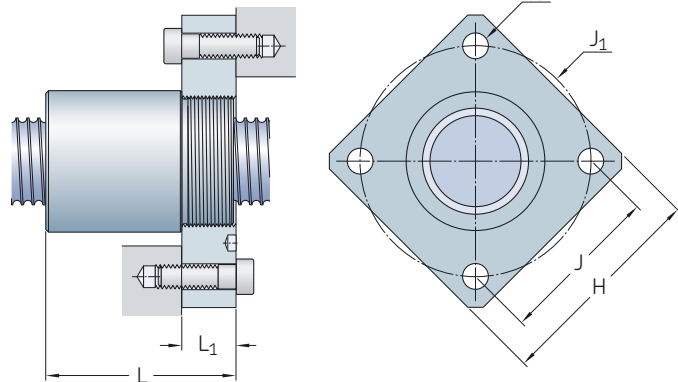

SX nut with trunnion flange (FHTF)

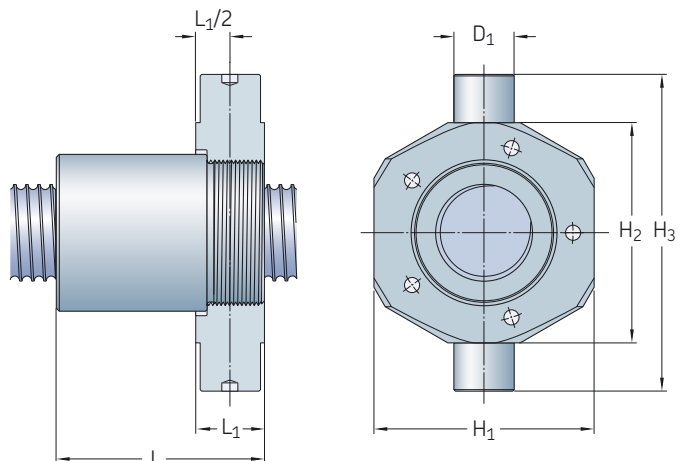

Nominal diameter d_0	Lead P_h	Dimensions					Designation
		L	L_1 h14	G	H h12	J js12	
mm	mm	mm					–
20	5	55	15	M5	52	44	FHRF 20
25	5	70	20	M6	60	50	FHRF 25
	10	85	20	M6	60	50	FHRF 25
32	5	65	20	M6	69	59	FHRF 32
	10	96	20	M6	69	59	FHRF 32
40	5	66	20	M8	82	69	FHRF 40×5
	10	106	25	M10	92	76	FHRF 40×10
	40	122	25	M10	92	76	FHRF 40×10
50	10	136	30	M12	110	91	FHRF 50
63	10	136	30	M12	125	106	FHRF 63

Nominal diameter d_0	Lead P_h	Dimensions					Designation	
		L	L_1 h14	H h14	J js12	J_1		N
mm	mm	mm					–	
20	5	55	15	60	45	63,6	6,6	FHSF 20
25	5	70	20	70	52	73,5	9	FHSF 25
	10	85	20	70	52	73,5	9	FHSF 25
32	5	65	20	80	60	84,8	9	FHSF 32
	10	96	20	80	60	84,8	9	FHSF 32
40	5	66	20	90	70	99	11	FHSF 40×5
	10	106	25	100	78	110,3	13	FHSF 40×10
	40	122	25	100	78	110,3	13	FHSF 40×10
50	10	136	30	120	94	133	15	FHSF 50
63	10	136	30	130	104	147	15	FHSF 63

Nominal diameter d_0	Lead P_h	Dimensions					Designation	Glycodur designation GLY PG	
		L	L_1	H_1 js16	H_2 h12	H_3 h12			D_1 h8
mm	mm	mm					–	–	
20	5	57	17	55	56	80	15	FHTF 20	151710A
25	5	71	21	60	65	97	18	FHTF 25	182015A
	10	86	21	60	65	97	18	FHTF 25	182015A
32	5	68	23	73	73	105	20	FHTF 32	202315A
	10	99	23	73	73	105	20	FHTF 32	202315A
40	5	69	23	85	85	117	20	FHTF 40×5	202315A
	10	108,5	27,5	98	98	140	25	FHTF 40×10	252820A
	40	124,5	27,5	98	98	140	25	FHTF 40×10	252820A
50	10	139	33	120	120	162	30	FHTF 50	303420A
63	10	139	33	135	135	177	30	FHTF 63	303420A



SND/BND precision screws, DIN standard 69051

Rolled thread ball screw with internal recirculation nut.

Standard version: composite inserts.

Special version: steel inserts which can act as a safety device for severe requirements or vertical applications. Contact us.

- Nominal diameter: 16 to 63 mm
- Lead: 5 to 10 mm
- Lubrication hole for nipple or automatic SKF SYSTEM 24
- Compact nut with integral flange for simple mounting and axial play
- Ground flanged nut: precise mounting
- Wipers available
- Backlash elimination by oversize balls on request (BND designation)
- Screw shaft can be phosphated on request
- Screw shaft accessories: FLBU–PLBU and BUF off the shelves (→ pages 42 to 47).

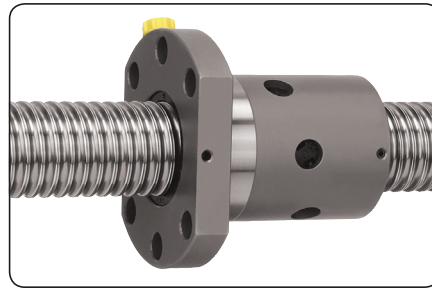

Standard

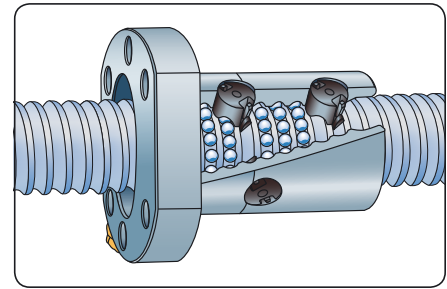

Recirculation

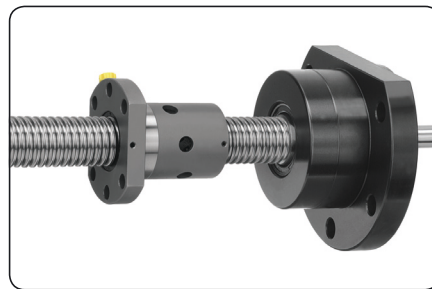

With flanged housing

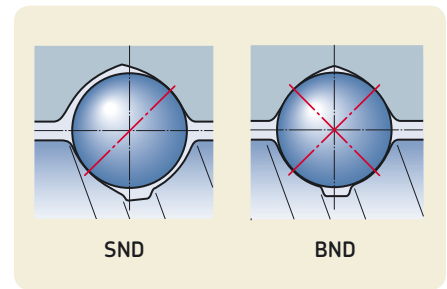

Nominal diameter	Lead (right hand)	Nut		Number of circuits of balls	Max play	Reduced play on request	Preload torque zero play T_{pr}	Inertia	Grease	Weight	Screw		Designation	
		Basic load dynamic	Basic load static								Mass	Inertia	Grease	–
d_0	P_h	C_a	C_{oa}		mm		Nm	kgmm ²	cm ³	kg	kg/m	kgmm ² /m	cm ³ /m	
16	5	8,1	12,4	3	0,08	0,05	0,05	40	1	0,23	1,3	33	2,1	SND/BND 16×5 R
	10	10,7	17											
20	5	11,7	18,3	3	0,1	0,05	0,08	86	1,1	0,24	2	85	2,7	SND/BND 20×5 R
	10	25,8	43,7											
25	5	13	22,7	3	0,1	0,05	0,11	117	1,6	0,29	3,3	224	3,4	SND/BND 25×5 R
	10	25,8	43,7											
32	5	19,1	40,4	4	0,1	0,05	0,21	364	2,1	0,54	5,6	641	4,5	SND/BND 32×5 R
	10	22,6	41,8											
40	5	25,4	63,2	5	0,1	0,05	0,36	855	3,1	0,92	9	1 639	5,6	SND/BND 40×5 R
	10	63,6	127,1											
50	10	70,6	157,6	5	0,12	0,08	0,88	2 130	13,1	1,8	13,6	3 736	6,5	SND/BND 50×10 R
63	10	78,4	202,9	5	0,12	0,08	1,23	4 075	16,1	2,4	22	9 913	8,4	SND/BND 63×10 R

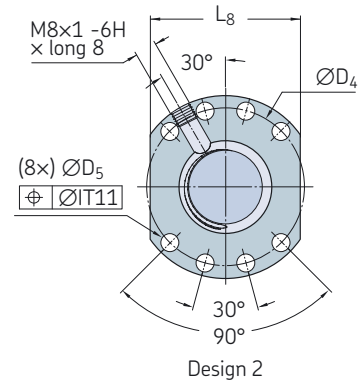
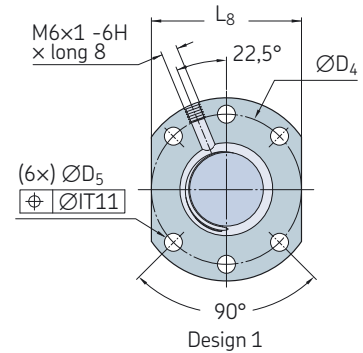
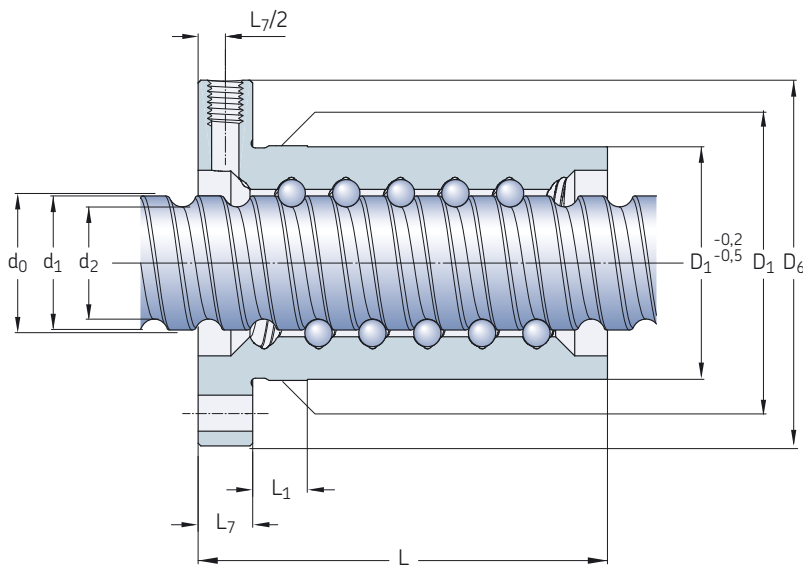

Screw	Nut									Screw			Support bearing Recommended thrust bearing type	Recommended support bearing type
$d_0 \times P_h$	D_1 g6	D_4	Design	D_5 H13	D_6 h13	L	L_1	L_7	L_8 h13	length max.	d_2	d_1		
mm	mm		-	mm						mm			-	
16×5	28	38	1	5,5	48	43,5	10	10	40	2 000	12,7	15,2	FLBU 16/PLBU 16	BUF 16
16×10	28	38	1	5,5	48	47	37	10	40	2 000	12,6	15,2	FLBU 16/PLBU 16	BUF 16
20×5	36	47	1	6,6	58	44,5	10	10	44	4 700	16,7	19,4	PLBU 20/FLBU 20	BUF 20
25×5	40	51	1	6,6	62	44,5	10	10	48	4 700	21,7	24,6	PLBU 25/FLBU 25	BUF 25
25×10	40	51	1	6,6	62	75	10	10	48	4 700	20,5	24,6	PLBU 25/FLBU 25	BUF 25
32×5	50	65	1	9	80	51,5	10	12	62	5 700	28,7	31,6	PLBU 32/FLBU 32	BUF 32
32×10	50	65	1	9	80	62,5	10	12	62	5 700	27,8	32	PLBU 32/FLBU 32	BUF 32
40×5	63	78	2	9	93	58,5	10	14	70	5 700	36,7	39,6	PLBU 40/FLBU 40	BUF 40
40×10	63	78	2	9	93	91	20	14	70	5 700	34	39,4	PLBU 40/FLBU 40/FLRBU 4¹⁾	BUF 40
50×10	75	93	2	11	110	93	10	16	85	5 700	44	49,7	PLBU 50/FLBU 50/FLRBU 5¹⁾	BUF 50
63×10	90	108	2	11	125	95	10	18	95	5 700	57	62,8	PLBU 63/FLBU 63	BUF 63

¹⁾ for high load application use FLRBU type, please refer to roller screws catalogue for end shaft and support bearing definitions

PND preloaded screws, DIN standard 69051

Rolled thread ball screw with internal recirculation nut.

Standard version: composite inserts.

Special version: steel inserts which can act as a safety device for severe requirements or vertical applications. Contact us.

- Nominal diameter: 16 to 63 mm
- Lead: 5 to 10 mm
- Lubrication hole for nipple or automatic SKF SYSTEM 24
- One-piece nut with integral flange offering an internal preload for optimum rigidity
- Wipers available
- Screw shaft can be phosphated on request
- Screw shaft accessories: FLBU–PLBU and BUF off the shelves (→ pages 42 to 47).

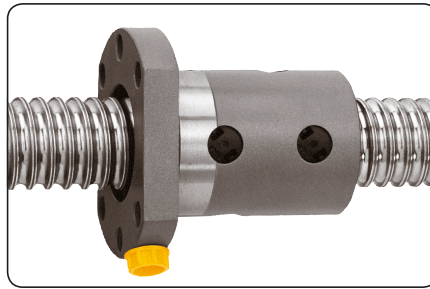

Standard

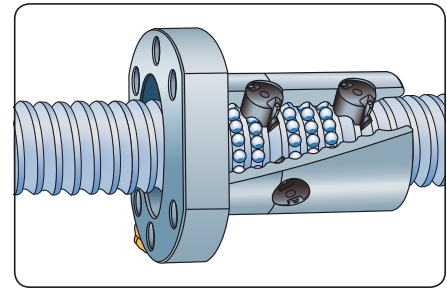

Recirculation

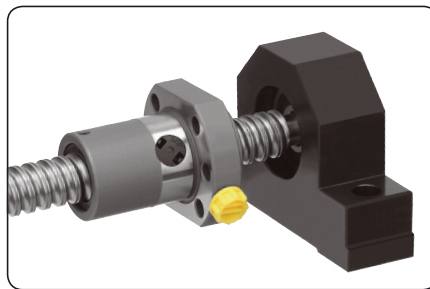

With plummer housing

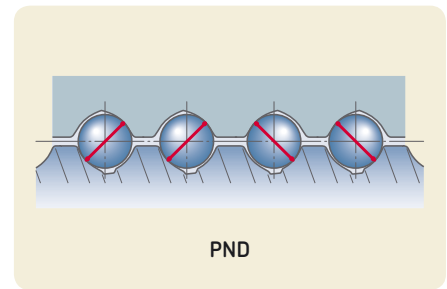

PND

Nominal diameter	Lead (right hand)	Nut		Number of circuits of balls	Preload torque average T_{pr}	Stiffness	Inertia	Grease	Weight	Screw			Designation
		Basic load ratings dynamic	static							Mass	Inertia	Grease	
d_0	P_h	C_a	C_{oa}			R_n				kg/m	kgmm ² /m	cm ³ /m	
mm	mm	kN		–	Nm	N/μm	kgmm ²	cm ³	kg				–
16	5	5,7	8,3	2×2	0,08	147	46	1	0,19	1,3	33	2,1	PND 16×5 R PND 16×10 R ¹⁾
	10	10,7	17	2×2×1,8	0,25	263	56	2,7	0,28	1,21	30,7	1,9	
20	5	8,2	12,2	2×2	0,14	248	91	1,3	0,26	2	85	2,7	PND 20×5 R
	10	13	22,7	2×3	0,28	436	405	2	0,4	3,3	224	3,4	PND 25×5 R PND 25×10 R
25	5	14,2	21,8	2×2	0,3	264	245	4,5	0,53	3,2	255	3,2	
	10	19,1	40,4	2×4	0,52	734	453	3,2	0,715	5,6	641	3,2	PND 32×5 R PND 32×10 R
32	5	22,6	41,8	2×3	0,61	490	490	7,6	0,81	5,6	639	4,1	
	10	25,4	63,2	2×5	0,71	968	1 110	4,8	1,3	9	1 639	5,5	PND 40×5 R PND 40×10 R
40	5	52,5	101,7	2×4	1,47	793	1 290	15,5	1,8	8,4	1 437	4,9	
	10	70,6	157,6	2×5	2,47	1 222	2 940	27,5	2,6	13,6	3 736	7,9	PND 50×10 R
50	10	78,4	202,9	2×5	3,46	1 448	5 290	26,8	3,2	22	9 913	7,9	PND 63×10 R

¹⁾ PND 16x10 is realised with double nut.

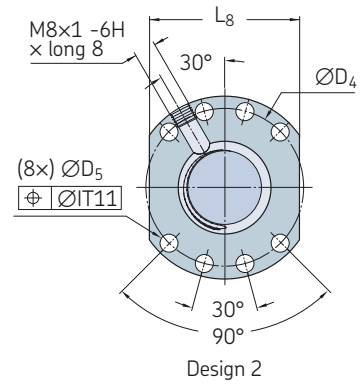
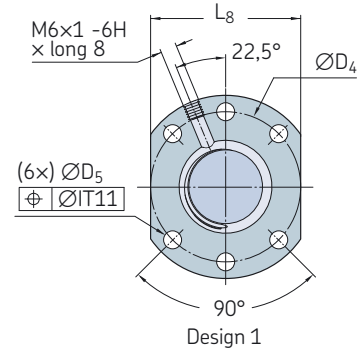
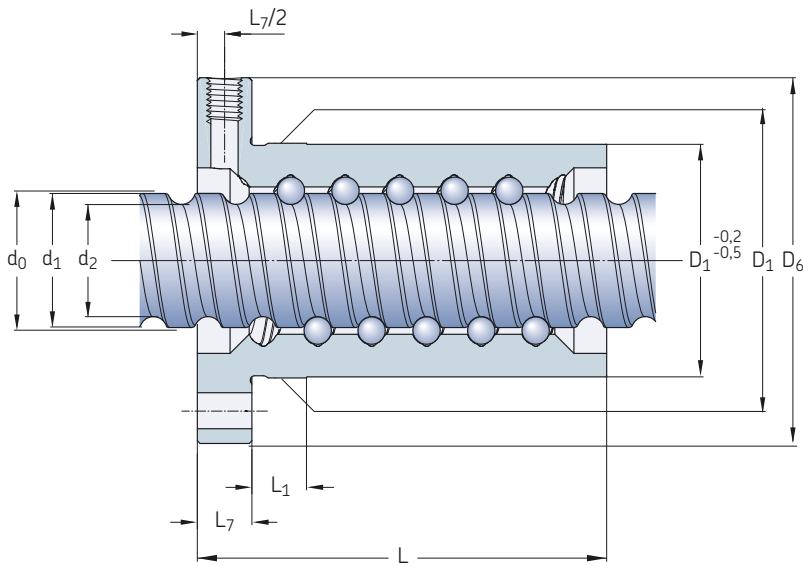

Screw	Nut		Design	D5 H13	D6 h13	L	L1	L7	L8 h13	Screw length max.	d2	d1	Support bearing Recommended thrust bearing type	Recommended support bearing type
	D1 g6	D4 js12												
mm	mm									mm				
16×5	28	38	1	5,5	48	48	10	10	40	2 000	12,7	15,2	FLBU 16/PLBU 16	BUF 16
16×10	28	38	1	5,5	48	87	77	10	40	2 000	12,6	15,2	FLBU 16/PLBU 16	BUF 16
20×5	36	47	1	6,6	58	50	10	10	44	4 700	16,7	19,4	PLBU 20/FLBU 20	BUF 20
25×5	40	51	1	6,6	62	62	10	10	48	4 700	21,7	24,6	PLBU 25/FLBU 25	BUF 25
25×10	40	51	1	6,6	62	75	10	10	48	4 700	20,5	24,6	PLBU 25/FLBU 25	BUF 25
32×5	50	65	1	9	80	74	10	12	62	5 700	28,7	31,6	PLBU 32/FLBU 32	BUF 32
32×10	50	65	1	9	80	100	10	12	62	5 700	27,8	32	PLBU 32/FLBU 32	BUF 32
40×5	63	78	2	9	93	88	10	14	70	5 700	36,7	39,6	PLBU 40/FLBU 40	BUF 40
40×10	63	78	2	9	93	130	20	14	70	5 700	34	39,4	PLBU 40/FLBU 40/FLRBU 4²⁾	BUF 40
50×10	75	93	2	11	110	151	10	16	85	5 700	44	49,7	PLBU 50/FLBU 50/FLRBU 5²⁾	BUF 50
63×10	90	108	2	11	125	153	10	18	95	5 700	57	62,8	PLBU 63/FLBU 63	BUF 63

²⁾ for high load application use FLRBU type, please refer to roller screws catalogue for end shaft and support bearing definitions

SN/BN precision screws

Rolled thread ball screw with internal recirculation nut.

Standard version: composite inserts.

Special version: steel inserts which can act as a safety device for severe requirements or vertical applications. Contact us.

- Nominal diameter: 16 to 63 mm
- Lead: 5 to 10 mm
- Lubrication hole for nipple or automatic SKF SYSTEM 24
- Compact nut with integral flange for simple mounting and axial play
- Ground flanged nut: precise mounting
- Wipers available
- Backlash elimination by oversize balls on request (BN designation)
- Screw shaft can be phosphated on request
- Screw shaft accessories: FLBU–PLBU and BUF off the shelves (→ **pages 42 to 47**).

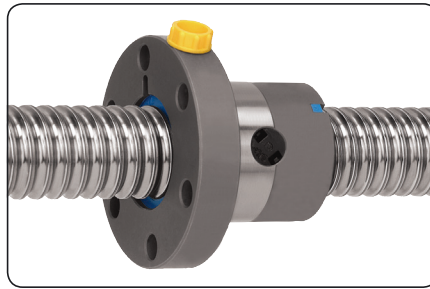

Standard

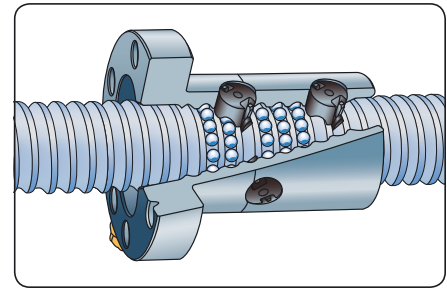

Recirculation

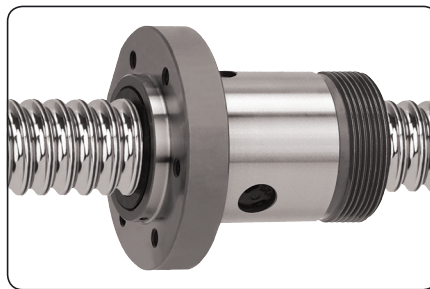

Customised

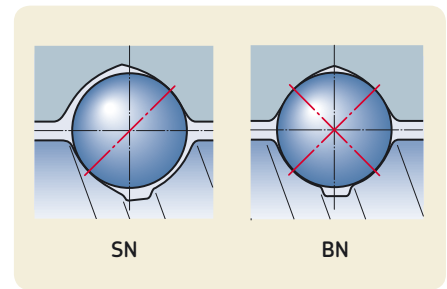

Nominal diameter	Lead (right hand)	Nut		Number of circuits of balls	Max play	Reduced play on request	Preload torque zero play T_{pr}	Inertia	Grease	Weight	Screw			Designation
		Basic load dynamic	static								Mass	Inertia	Grease	
d_0	P_h	C_a	C_{oa}		mm		Nm	kgmm ²	cm ³	kg	kg/m	kgmm ² /m	cm ³ /m	–
mm	mm	kN	–	–	mm		Nm	kgmm ²	cm ³	kg	kg/m	kgmm ² /m	cm ³ /m	–
16	5	8,1	12,4	3	0,08	0,05	0,05	45	0,9	0,18	1,3	33	2,1	SN/BN 16×5 R
20	5	11,7	18,3	3	0,1	0,05	0,08	88	1,2	0,24	2	85	2,7	SN/BN 20×5 R
25	5	13	22,7	3	0,1	0,05	0,11	127	1,6	0,28	3,3	224	3,4	SN/BN 25×5 R
	10	25,8	43,7	4	0,12	0,08	0,23	244	4,5	0,53	5,6	255	3,2	SN/BN 25×10 R
32	5	19,1	40,4	4	0,1	0,05	0,21	250	2,1	0,4	5,6	641	4,5	SN/BN 32×5 R
	10	22,6	41,8	3	0,12	0,08	0,25	673	4,6	0,83	5,7	639	4,2	SN/BN 32×10 R
40	5	25,4	63,2	5	0,1	0,05	0,36	495	3,1	0,58	9	1 639	5,6	SN/BN 40×5 R
	10	63,6	127,1	5	0,12	0,08	0,64	1 285	10,7	1,4	8,4	1437	5,1	SN/BN 40×10 R
50	10	70,6	157,6	5	0,12	0,08	0,88	1 305	13,1	1,8	13,6	3 736	6,5	SN/BN 50×10 R
63	10	78,4	202,9	5	0,12	0,08	1,23	4 180	16,1	2,25	22	9 913	8,4	SN/BN 63×10 R

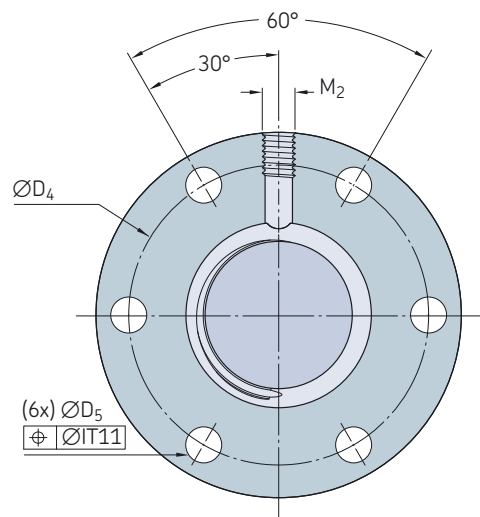
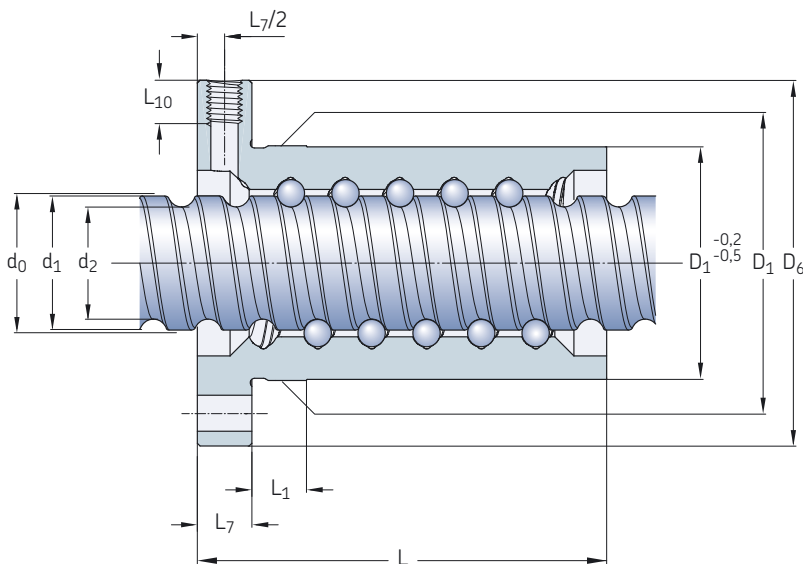

Screw	Nut		Screw							Screw	Support bearing		Recommended thrust bearing type	Recommended support bearing type
$d_0 \times P_h$	D_1 g9	D_4	D_5 H13	D_6 h13	L	L_1	L_7	L_{10}	M_2 6H	length max.	d_2	d_1		
mm	mm									mm	mm		-	
16×5	28	38	6×5.5	48	43,5	10	10	8	M6	2000	12,7	15,2	FLBU 16 / PLBU 16	BUF 16
20×5	33	45	6×6.6	57	44,5	10	10	8	M6	4700	16,7	19,4	PLBU 20 / FLBU 20	BUF 20
25×5	38	50	6×6.6	62	44,5	10	10	8	M6	4700	21,7	24,6	PLBU 25 / FLBU 25	BUF 25
25×10	43	55	6×6.6	67	75	10	10	8	M6	4700	20,5	24,6	PLBU 25 / FLBU 25	BUF 25
32×5	45	58	6×6.6	70	51,5	10	12	8	M6	5700	28,7	31,6	PLBU 32 / FLBU 32	BUF 32
32×10	54	70	6×9	87	62,5	10	12	10	M8×1	5700	27,8	32	PLBU 32 / FLBU 32	BUF 32
40×5	53	68	6×6.6	80	58,5	10	14	8	M6	5700	36,7	39,6	PLBU 40 / FLBU 40	BUF 40
40×10	63	78	6×9	95	91	20	14	10	M8×1	5700	34	39,4	PLBU 40 / FLBU 40 / FLRBU 4¹⁾	BUF 40
50×10	72	90	6×11	110	99	10	16	10	M8×1	5700	44	49,7	PLBU 50 / FLBU 50 / FLRBU 5¹⁾	BUF 50
63×10	85	105	6×11	125	101	10	18	10	M8×1	5700	57	62,8	PLBU 63 / FLBU 63	BUF 63

¹⁾ for high load application use FLRBU type, please refer to roller screws catalogue for end shaft and support bearing definitions

PN preloaded screws

Rolled thread ball screw with internal recirculation nut.

Standard version: composite inserts.

Special version: steel inserts which can act as a safety device for severe requirements or vertical applications.

Contact us.

- Nominal diameter: 16 to 63 mm
- Lead: 5 to 10 mm
- Lubrication hole for nipple or automatic SKF SYSTEM 24
- One-piece nut with integral flange offering an internal preload for optimum rigidity
- Wipers available
- Screw shaft can be phosphated on request
- Screw shaft accessories: FLBU–PLBU and BUF off the shelves (→ pages 42 to 47).

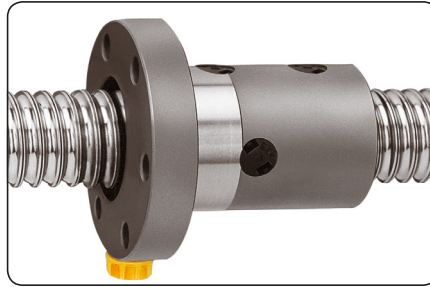

Standard

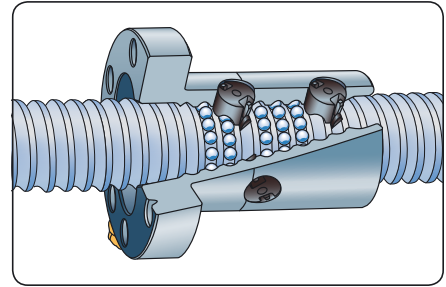

Recirculation

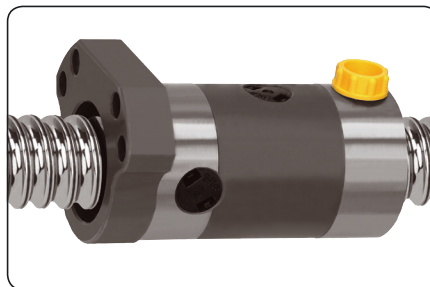

Customised

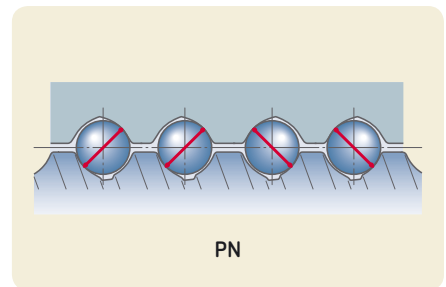

PN

Nominal diameter	Lead (right hand)	Nut		Number of circuits of balls	Preload torque average T_{pr}	Stiffness R_n	Inertia	Grease	Weight	Screw			Designation
		Basic load dynamic C_a	ratings static C_{oa}							Mass	Inertia	Grease	
d_0	P_h									kg/m	kgmm ² /m	cm ³ /m	–
mm	mm	kN	–	–	Nm	N/μm	kgmm ²	cm ³	kg				
16	5	5,7	8,3	2×2	0,08	147	46	1	0,19	1,3	33	2,1	PN 16×5 R
20	5	8,2	12,2	2×2	0,14	248	91	1,1	0,26	2	85	2,4	PN 20×5 R
25	5	13	22,7	2×3	0,28	436	400	2,1	0,39	3,3	224	3,4	PN 25×5 R
	10	14,2	21,8	2×2	0,3	264	245	4,1	0,53	3,2	255	2,8	PN 25×10 R
32	5	19,1	40,4	2×4	0,52	734	390	3,2	0,5	5,6	641	4,4	PN 32×5 R
	10	22,6	41,8	2×3	0,61	490	830	7,6	1,13	5,6	639	4,1	PN 32×10 R
40	5	25,4	63,2	2×5	0,71	968	585	4,8	0,74	9	1 639	5,5	PN 40×5 R
	10	52,5	101,7	2×4	1,47	793	1 530	14,6	1,8	8,4	1 437	4,9	PN 40×10 R
50	10	70,6	157,6	2×5	2,47	1 222	2 930	27,5	2,6	13,6	3 736	7,9	PN 50×10 R
63	10	78,4	202,9	2×5	3,46	1 448	5 980	26,8	3,2	22	9 913	7,9	PN 63×10 R

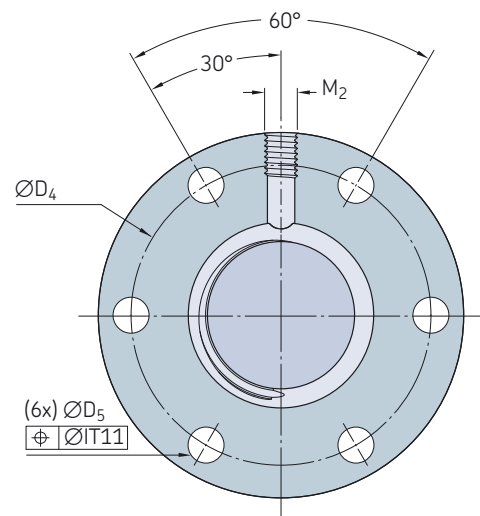
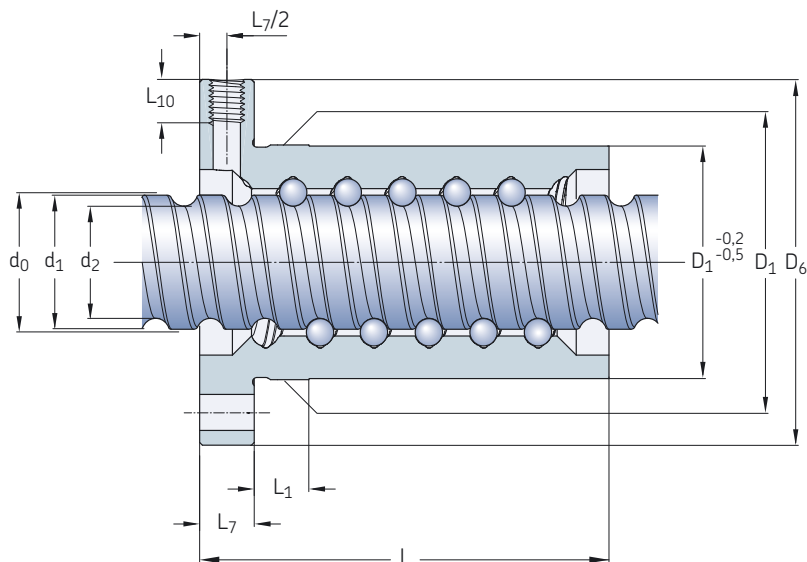

Screw	Nut									Screw			Support bearing	Recommended thrust	Recommended
$d_0 \times P_h$	D_1	D_4	D_5	D_6	L	L_1	L_7	L_{10}	M_2	length	d_2	d_1	Recommended bearing type	bearing type	support bearing type
mm	mm									mm	mm		-		
16×5	28	38	6×5,5	48	48	10	10	8	M6	2 000	12,7	15,2	FLBU 16/PLBU 16		BUF 16
20×5	33	45	6×6,6	57	50	10	10	8	M6	4 700	16,7	19,4	PLBU 20/FLBU 20		BUF 20
25×5	38	50	6×6,6	62	62	10	10	8	M6	4 700	21,7	24,6	PLBU 25/FLBU 25		BUF 25
25×10	43	55	6×6,6	67	75	10	10	8	M6	4 700	20,5	24,6	PLBU 25/FLBU 25		BUF 25
32×5	45	58	6×6,6	70	74	10	12	8	M6	5 700	28,7	31,6	PLBU 32/FLBU 32		BUF 32
32×10	54	70	6×9	87	100	10	12	10	M8×1	5 700	27,8	32	PLBU 32/FLBU 32		BUF 32
40×5	53	68	6×6,6	80	88	10	14	8	M6	5 700	36,7	39,6	PLBU 40/FLBU 40		BUF 40
40×10	63	78	6×9	95	126	20	14	10	M8×1	5 700	34	39,4	PLBU 40/FLBU 40/FLRBU 4¹⁾		BUF 40
50×10	72	90	6×11	110	151	10	16	10	M8×1	5 700	44	49,7	PLBU 50/FLBU 50/FLRBU 5¹⁾		BUF 50
63×10	85	105	6×11	125	153	10	18	10	M8×1	5 700	57	62,8	PLBU 63/FLBU 63		BUF 63

¹⁾ for high load application use FLRBU type, please refer to roller screws catalogue for end shaft and support bearing definitions

SL/TL long lead screws

Ball circulation system allowing high linear speed.

- Nominal diameter: 25 to 50 mm
- Lead: 20 to 50 mm
- Lubrication hole for nipple or automatic SKF SYSTEM 24
- Two versions:
 - nut with axial play “SL”
 - nut with backlash elimination “TL”
- Double protection with polyamide wipers and brush wipers (WPR = with brush wipers, NOWPR = without brush wipers)
- Screw shaft can be phosphated on request
- Screw shaft accessories: FLBU–PLBU and BUF off the shelves (→ **pages 42 to 47**).

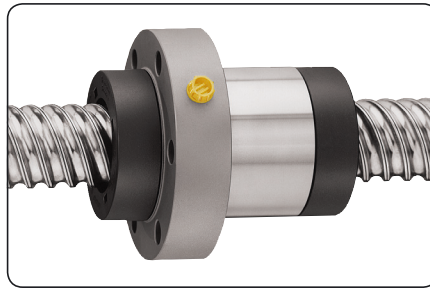

Standard

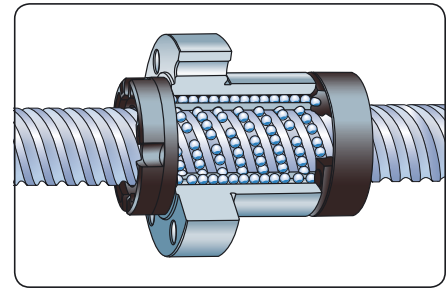

Recirculation

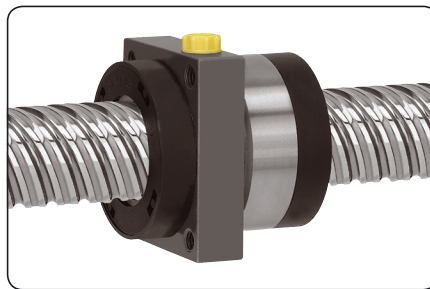

Customised

Nominal diameter	Lead (right hand)	Nut			TL (with backlash elimination)				Screw			Designation			
		SL (with play)	Basic load ratings	Max play	Basic load ratings	Preload torque	Number of circuits of balls	Inertia	Grease	Weight	Mass	Inertia	Grease		
d_0	P_h	C_a	C_{0a}		C_a	C_{0a}	T_{pr}								
mm	mm	kN		mm	kN		Nm	–	kgmm ²	cm ³	kg	kg/m	kgmm ² /m	cm ³ /m	–
25	20	23	51,6	0,08	12,7	25,8	0,04-0,36	4×1,7	480	3	0,57	3,3	215	3,4	SL/TL 25×20 R
	25	22,6	51	0,08	12,5	25,5	0,04-0,36	4×1,7	400	3,6	0,66	3,2	210	3,3	SL/TL 25×25 R
32	20	25,7	65,3	0,08	14,1	32,6	0,05-0,45	4×1,7	550	3,4	0,7	5,1	530	4,4	SL/TL 32×20 R
	32	26	68,3	0,08	14,3	34,1	0,05-0,50	4×1,8	450	4,5	0,7	5,4	600	4,3	SL/TL 32×32 R
	32	26	68,3	0,08	14,3	34,1	0,05-0,50	4×1,8	450	4,5	0,7	5,4	600	4,3	SLD/TLD 32×32 R
	40	15,7	38,6	0,08	8,7	19,3	0,05-0,50	4×0,8	515	3	0,65	4,9	490	4,4	SL/TL 32×40 R
40	20	41,8	129,4	0,08	23,1	64,7	0,05-0,55	4×2,7	1 420	6,6	1,2	8,2	1 380	5,5	SL/TL 40×20 R
	40	53,3	133,8	0,1	29,4	66,9	0,05-0,55	4×1,7	3 300	12,5	2,4	8,1	1 330	5,2	SL/TL 40×40 R
50	50	94,8	238,2	0,12	52,2	119,1	0,1-0,9	4×1,7	6 060	19,4	3,3	13,2	3 560	6,4	SL/TL 50×50 R

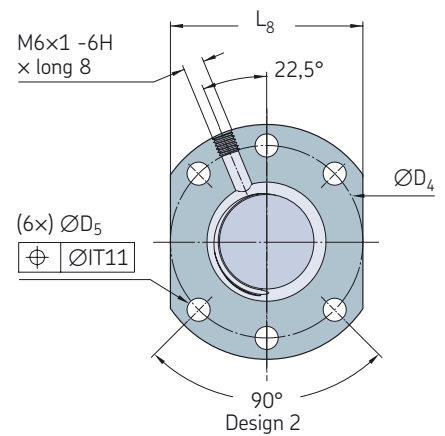
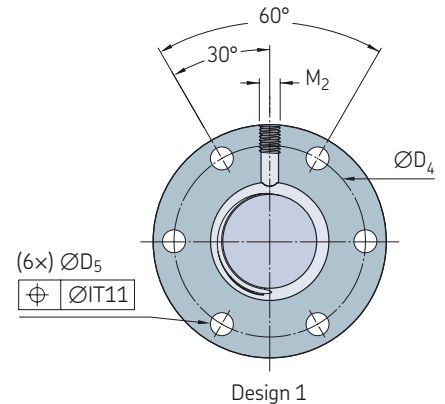
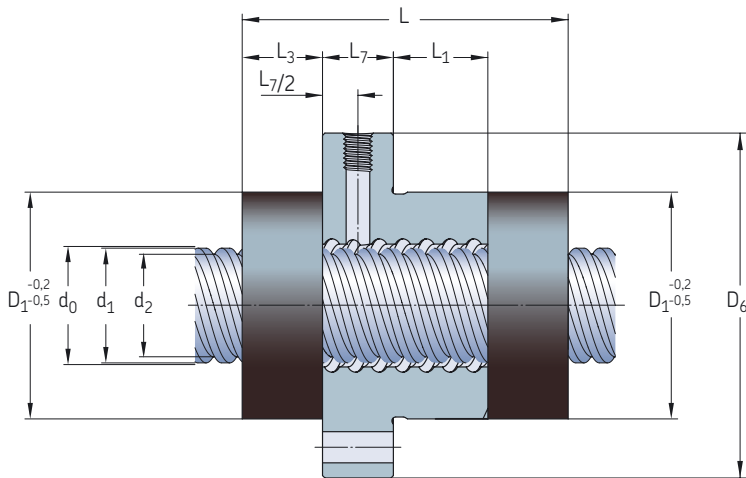

Screw	Nut											Screw	Support bearing	Recommended thrust bearing type	Recommended support bearing type		
$d_0 \times P_h$	D_1 g9	D_4 js12	Design	D_5 H13	D_6	L	L_1	L_3	L_7	L_8 h13	L_{10}	M_2	length max.	d_2	d_1		
mm	mm	-		mm									mm			-	
25×20	48	60	1	6×6,6	73	66,4	18	17,4	15	N/A	8	M6	4 700	21,7	24,3	PLBU 25/FLBU 25	BUF 25
25×25	48	60	1	6×6,6	73	77,9	27	18,6	15	N/A	8	M6	4 700	21,5	24,4	PLBU 25/FLBU 25	BUF 25
32×20	56	68	1	6×6,6	80	66,4	18	17,4	15	N/A	8	M6	5 700	27,5	30	PLBU 32/FLBU 32/FLRBU3 ¹⁾	BUF 32
32×32	56	68	1	6×6,6	80	80,3	41	13	15	N/A	8	M6	5 700	28,4	31,1	PLBU 32/FLBU 32/FLRBU3 ¹⁾	BUF 32
32×32	50 g6	65	2	6×9	80	80,3	41	13	15	62	8	M6	5 700	28,4	31,1	PLBU 32/FLBU 32/FLRBU3 ¹⁾	BUF 32
32×40	53 g6	68	1	6×6,6	80	55	17	12	15	N/A	8	M6	5 700	26,9	29,6	PLBU 32/FLBU 32	BUF 32
40×20	63	78	1	6×9	95	86,8	38	17,8	15	N/A	8	M6	5 700	35,2	37,7	PLBU 40/FLBU 40	BUF 40
40×40	72	90	1	6×11	110	110,3	44	21,3	25	N/A	10	M8×1	5 700	34,2	38,3	PLBU 40/FLBU 40/FLRBU 4 ¹⁾	BUF 40
50×50	85	105	1	6×11	125	134	60	25,5	25	N/A	10	M8×1	5 700	43,5	49,1	PLBU 50/FLBU 50/FLRBU 5 ¹⁾	BUF 50

¹⁾ for high load application use FLRBU type, please refer to roller screws catalogue for end shaft and support bearing definitions



SLT/TLT rotating nut

Long lead rolled ball screw with rotating nut

Concept

The nut rotates inside bearings and moves along the fixed long lead screw shaft.

The drive motor moves with the nut, so inertia and critical speed problems, associated with a long rotating shaft, are minimised.

Design details

- 72 series angular contact bearings are directly mounted on the nut.
- They are preloaded in "0" configuration in order to fully support the torque due to the belt tension.
- 2 Nilos seals protect these bearings against pollution and permit lubrication for life.
- Two versions available:
 - Ball screw with axial play: SLT
 - Ball screw with backlash elimination: TLT
- Two brush wipers are mounted in the standard configuration for better protection.
- Ball screw lubrication: through the nipple placed on the housing external diameter in the standard version, or as an option through the screw shaft.
- Ball nut greased with SKF LGMT2. Other lubricants possible on request.

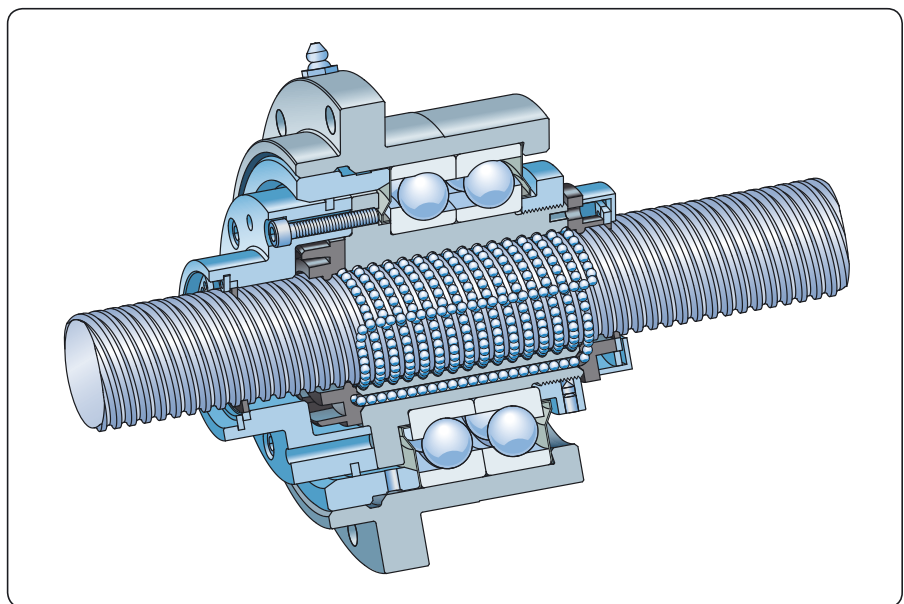
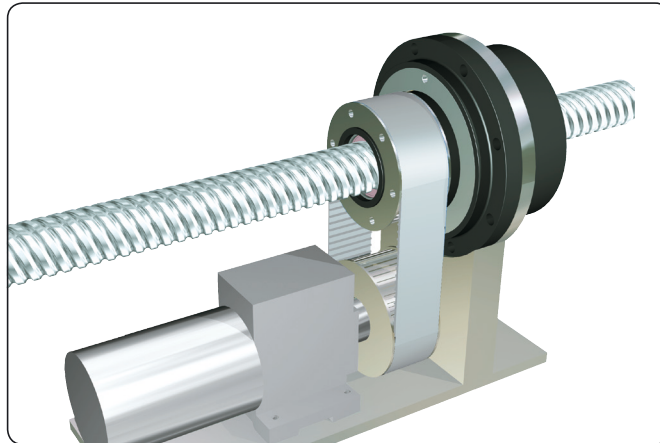

Nominal diameter	Lead (right hand)	Ball screw capacities				Bearing		Rotating nut			Designation	
		SL Basic load ratings	TL Basic load ratings	SL Basic load ratings	TL Basic load ratings	Basic load ratings	Basic load ratings	Max trans- missible torque	Max trans- missible axial load	Inertia with pulley support		Mass
d_0	P_h	C_a	C_{oa}	C_a	C_{oa}	C_a	C_{oa}					
mm	mm	kN				kN		Nm	kN	kgmm ²	kg	–
25	20	39,5	96,6	21,8	48,3	61,8	56	180	68,3	1 012	4,5	SLT/TLT 25×20 R
	25	33,5	80,5	18,5	40,2	61,8	56	180	68,3	1 023	4,6	SLT/TLT 25×25 R
32	20	49,9	141,2	27,5	70,6	78	76,5	209	107	1 935	7,2	SLT/TLT 32×20 R
	32	32,1	87,3	17,6	43,7	78	76,5	209	87,3	1 919	7,1	SLT/TLT 32×32 R
	40	30	81,7	16,5	40,8	78	76,5	209	81,7	1 949	7,1	SLT/TLT 32×40 R
40	20	54,6	176,7	30,1	88,3	93,6	91,5	240	116	3 095	7,5	SLT/TLT 40×20 R
	40	53,3	133,8	29,4	66,9	114	118	246	93,3	3 784	8,4	SLT/TLT 40×40 R
50	50	94,8	238,2	52,3	119,1	156	166	803	162	1 1482	15,5	SLT/TLT 50×50 R

Benefits

- Easy and simple to incorporate.
- Compact solution, ready to use.
- Fixed screw shaft: simplified mounting.
- Inertia considerably reduced:
3 800 kgmm² instead of 6 000 kgmm²
for a screw shaft, 40×40–4,5 m stroke.
- Smaller, lighter, lower power motors.
- Higher linear speeds: up to 110 m/min.

Screw Dimensions

$d_0 \times P_h$	L	L ₁	L ₂	L ₃	L ₄	L ₅	L ₆	L ₇	L ₈	L ₉
mm										
25×20	121	15	12,4	19,9	74	2,9	16,8	12,4	15	15
25×25	126,2	15	12,4	19,9	74	2,9	21,9	12,4	15	15
32×20	132,4	20	3,8	27,5	89	2,2	17,4	20	15	20
32×32	126,8	20	3,8	27,5	89	2,2	11,8	20	15	20
32×40	125,7	20	3,8	27,5	89	2,2	10,7	20	15	20
40×20	136,4	20	9,3	22,5	85	4,7	17,4	15	15	20
40×40	159,3	47	8,8	19	83	0	20,5	11,5	15	20
50×50	163,3	20	15,5	25,4	100	4,5	23,5	15,7	20	25

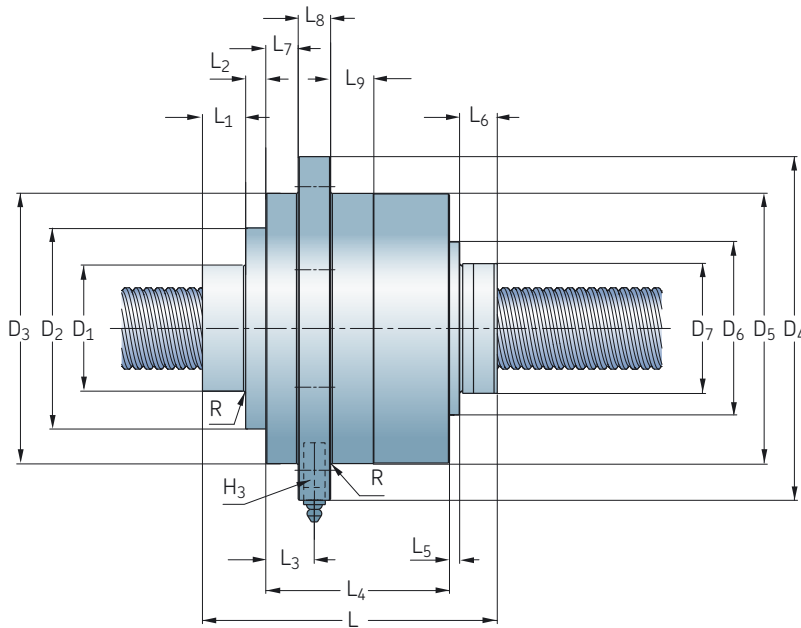

Screw Dimensions

$d_0 \times P_h$	D ₁	D ₂	D ₃	D ₄	D ₅ g6	D ₆	D ₇	R max.	J ₁	J ₂	Z ₁ × H ₁	Z ₁ × H ₁ × useful depth	H ₃
mm													
25×20	40	72,5	100	133	100	65	48	0,8	116	55	6×Ø9	6×M6×20	M6×1
25×25	40	72,5	100	133	100	65	48	0,8	116	55	6×Ø9	6×M6×20	M6×1
32×20	50	82	119,5	150	120	76	56	0,8	135	68	6×Ø9	6×M6×20	M6×1
32×32	50	82	119,5	150	120	76	50	0,8	135	68	6×Ø9	6×M6×20	M6×1
32×40	50	82	119,5	150	120	76	53	0,8	135	68	6×Ø9	6×M6×20	M6×1
40×20	58	93	125	159	125	80	63	0,8	142	75	8×Ø9	6×M6×20	M8×1
40×40	60	93	137	168	137	102	72	1,6	153	80	8×Ø9	6×M6×20	M8×1
50×50	70	120	170	210	170	110	85	1,6	190	106	8×Ø11	6×M8×30	M8×1

All tolerances js13 if not specified.

Shaft end combinations

In the order code, shaft end machining is defined by:

- one letter for diameter < 16 mm
- two letters for diameter ≥ 16 mm

resulting from the combination of two machined ends (→ designation **page 50**).

Machined ends are represented in details in **page 37** for diameter < 16 mm and **page 38** for diameter ≥ 16 mm.

UA end machining

*) UA: end machined to diameter d_3 under induction hardening, any possible lengths (→ **fig. 11**).

Diameter < 16 mm		Diameter ≥ 16 mm	
Order code	Two machined ends	Order code	Two machined end
A (without length indication)	cut only	AA (without length indication)	cut only
A (+ length)	cut + annealed		
B	1 + 2	BA	1A + 2A
F ¹⁾	2 + 2	FA ¹⁾	2A + 2A
G ¹⁾	2 + 3	GA ¹⁾	2A + 3A
H	2 + 4	HA	2A + 4A
J	2 + 5	JA	2A + 5A
M	3 + 5	MA	3A + 5A
S (+ length)	Ends to root diameter, any possible lengths	SA (+ length)	Ends to root diameter d_2 , any possible lengths.
		UA*) (+ length)	End machined to diameter d_3 under induction hardening, any possible lengths.
K	Keyway	K	Keyway
Z	To customer's drawing	Z	To customer's drawing

¹⁾Attention! This mounting requires the greatest precautions. Please contact us.

Fig. 11

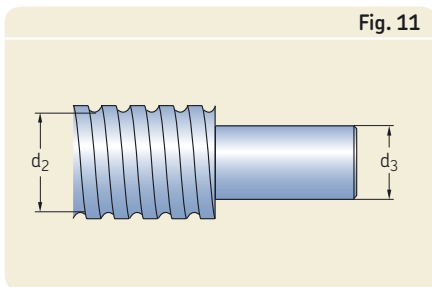

Dimensions	d_2	d_3
	mm	mm
16×5	12,7	9
20×5	16,7	14
25×5	21,7	19
25×10	20,5	18
25×20	21,7	19
25×25	21,5	18
32×5	28,7	26
32×10 DIN	27,8	25
32×10	26	23
32×20	27,5	24
32×32	28,4	26
32×40	26,9	24

Dimensions	d_2	d_3
	mm	mm
40×5	36,7	34
40×10	34	31
40×20	35,2	32
40×40	34,2	31
50×10	44	41
50×50	43,5	40
63×10	57	54

Standard end machining for nominal diameter < 16 mm

Special ends are machined to customers drawing on request.

For SD/SH/SDS/SHS/BD/BDS

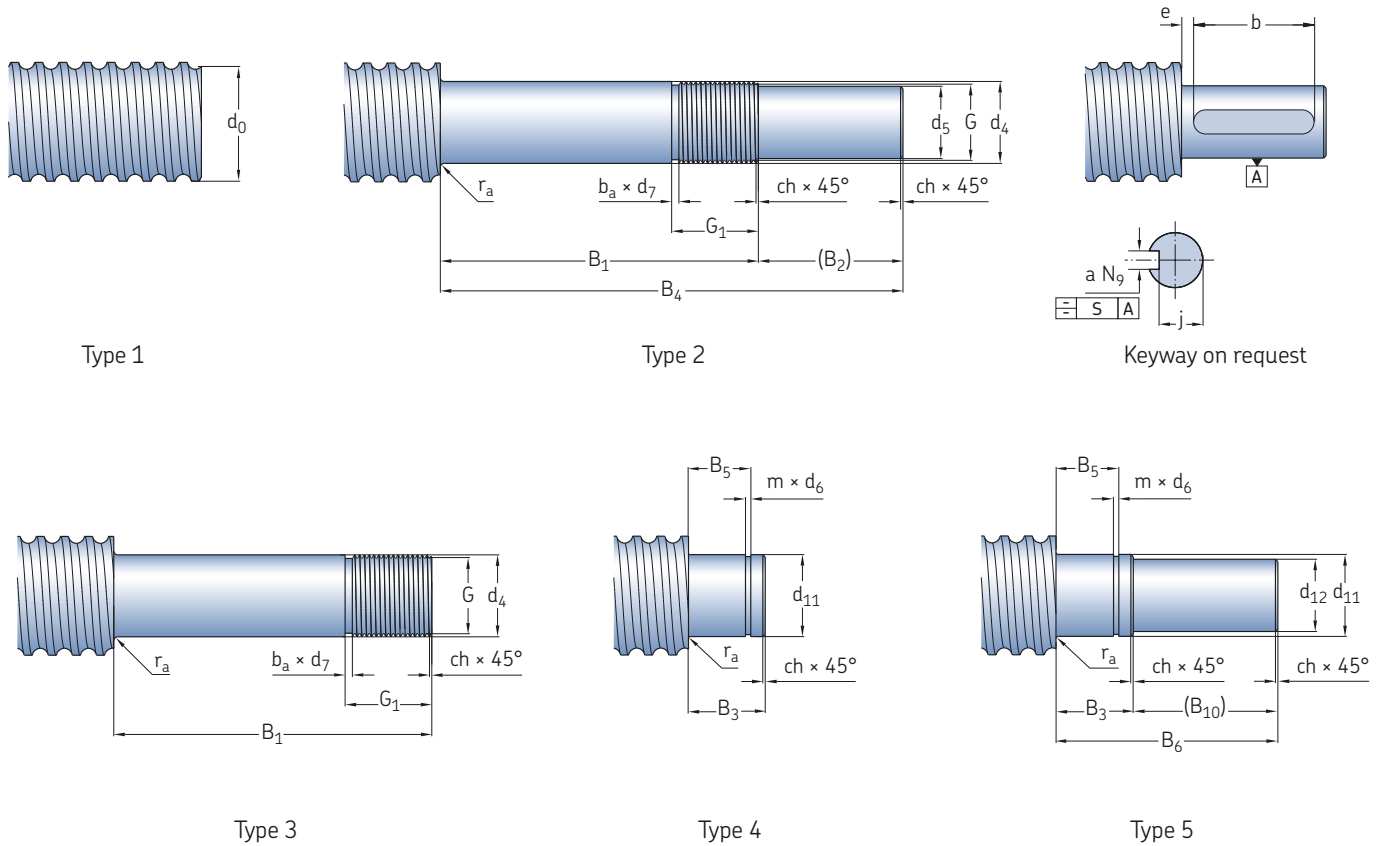

Dimensions

d_0	d_5 h7	d_4 js7	B_1 js12	B_2	B_3 js12	B_4 js12	B_5 H11	B_6 js12	G 6g	G_1	m +0,14 0	d_6 h11/ h12	ch	b_a	d_7 h11	r_a max.	a N9	b +0,5 0	e	j	S	Keyway DIN 6885
6	3	4	22	10	7	32	5,4	17	M4×0,7	7	0,5	3,8	0,5	1,2	2,9	-	-	-	-	-	-	-
8	4	5	24	12	7	36	5,6	19	M5×0,8	7,2	0,7	4,8	0,5	1,2	3,7	0,3	-	-	-	-	-	-
10	5	6	26	12	9	38	6,7	21	M6×1	7,5	0,8	5,7	0,5	1,5	4,5	0,3	-	-	-	-	-	-
12/12,7	6	8	38	12	10	50	7,8	22	M8×1	12,5	0,9	7,6	0,5	1,5	6,5	0,3	2	8	3	4,8	0,1	A2×2×8
14	8	10	40	16	12	56	9	28	M10×1,5	13,3	1,1	9,6	0,5	2,3	7,8	0,3	2	10	3	6,8	0,1	A2×2×10

Standard end machining for nominal diameter ≥ 16 mm

For SD/BD/SDS/BDS–SX/BX–SN/BN/PN–SND/BND/PND

Standard shaft ends for ball screws, nominal diameter ≥ 16 mm, have been developed to suit the SKF thrust bearings FLBU, PLBU and BUF.

End bearing	Machined end type
FLBU	2A or 3A
PLBU	2A or 3A
BUF	4A or 5A

The maximum permissible dynamic load, is 75 % of product dynamic load rating.

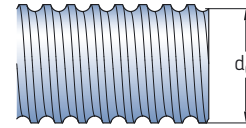

Type 1A

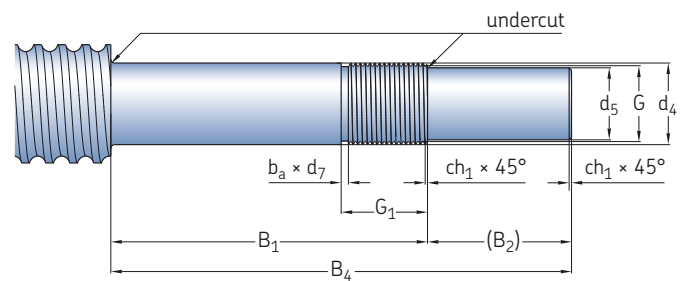

Type 2A

Size												
d_0	d_5	d_4	d_{11}	d_{12}	B_1	B_2	B_3	B_4	B_5	B_6	B_7	d_8
–	h7	h6	h6	h7	js12		js12	js12	H11	js12		
mm												
16	8	10	10	8	53	16	13	69	10	29	2	12,5
20	10	12	10	8	58	17	13	75	10	29	2	14,5
25 ¹⁾	15	17	17	15	66	30	16	96	13	46	4,5	20
32 ¹⁾	17	20	17	15	69	30	16	99	13	46	4,5	21,7
40 ¹⁾	25	30	30	25	76	45	22	121	17,5	67	4,5	33,5
50 ¹⁾	30	35	30	25	84	55	22	139	17,5	67	4,5	35,2
63	40	50	45	40	114	65	28	179	20,75	93	3	54

¹⁾ for SL/TL screws see pages 40 and 41.

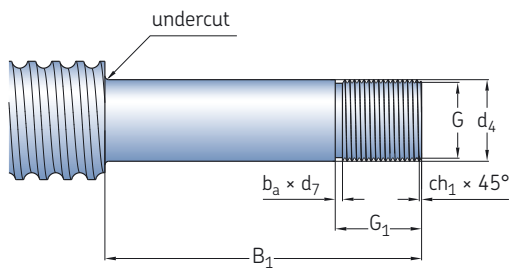

Type 3A

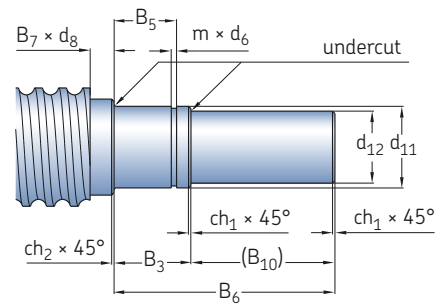

Type 5A

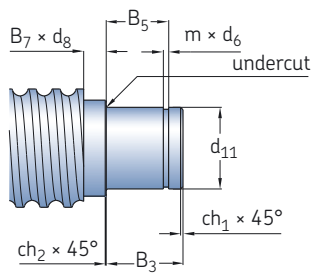

Type 4A

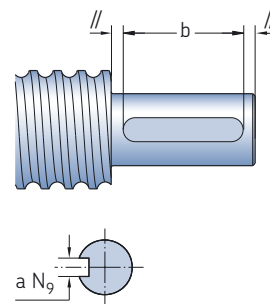

Keyway on request

Size										Keyway to DIN 6885	
d_0	G 6g	G_1	m +0,14 0	d_6 h11	h12	ch ₁	ch ₂	b_a	d_7 h11	$a^{N9} \times l \times b$	
										fixed end (type 2A)	fixed end (type 5A)
16	M10×0,75	17	1,1	9,6		0,5	0,5	1,2	8,8	A2×2×12	A2×2×12
20	M12×1	18	1,1	9,6		0,5	0,5	1,5	10,5	A3×3×12	A2×2×12
25	M17×1	22	1,1	16,2		0,5	0,5	1,5	15,5	A5×5×25	A5×5×25
32	M20×1	22	1,1	16,2		0,5	0,5	1,5	18,5	A5×5×25	A5×5×25
40	M30×1,5	25	1,6		28,6	1	0,5	2,3	27,8	A8×7×40	A8×7×40
50	M35×1,5	27	1,6		28,6	1	0,5	2,3	32,8	A8×7×45	A8×7×40
63	M50×1,5	32	1,85		42,5	1,5	1	2,3	47,8	A12×8×50	A12×8×50

Standard end machining for SL/TL only

Standard shaft ends for SL/TL ball screws have been developed to suit the SKF thrust bearings FLBU, PLBU and BUF.

For the "SL/TL" long lead screw, an additional shoulder, part of the threaded length, will be machined to protect the wiper and nut thread during assembly (both sides).

End bearing	Machined end type
FLBU	2A or 3A
PLBU	2A or 3A
BUF	4A or 5A

The maximum permissible dynamic load is 75 % of product dynamic load rating, except for 50x50 which is 40 kN maximum.

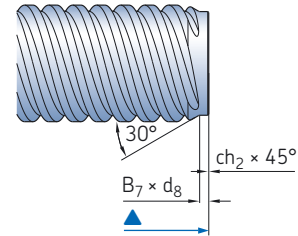

Type 1A

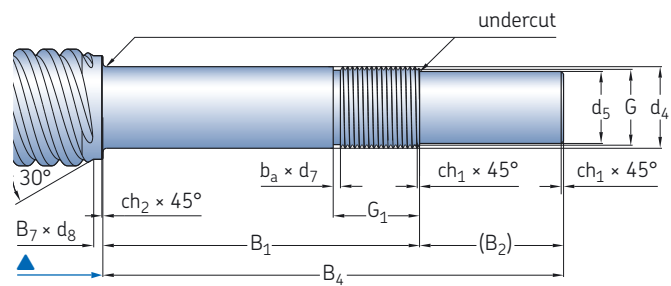

Type 2A

Size														
d_0	d_5	d_4	d_{10}	d_{11}	d_{12}	B_{12}	B_2	B_3	B_4	B_5	B_6	B_7	B_9	d_8
-	h7	h6		h6	h7	js12		js12	js12	H11	js12			
mm														
25x20	15	17	-	17	15	66	30	16	96	13	46	4,5	0	21,7
25x25	15	17	-	17	15	66	30	16	96	13	46	4,5	0	21,5
32x20	17	20	21,5	17	15	69	30	16	99	13	46	4,5	2	27,4
32x32	17	20	21,5	17	15	69	30	16	99	13	46	4,5	2	28,4
32x40	17	20	21,5	17	15	76	30	16	99	13	46	4,5	2	26,9
40x20	25	30	-	30	25	76	45	22	121	17,5	67	6,5	0	35,2
40x40	25	30	-	30	25	76	45	22	121	17,5	67	6,5	0	35
50x50	30	35	37	30	25	84	55	22	139	17,5	67	9	3	43,4

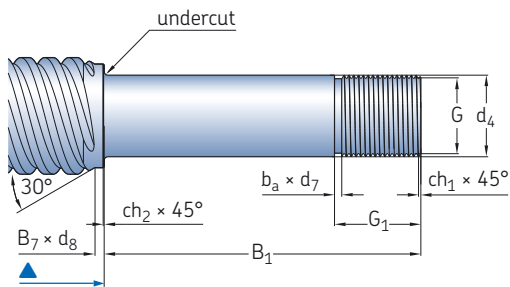

Type 3A

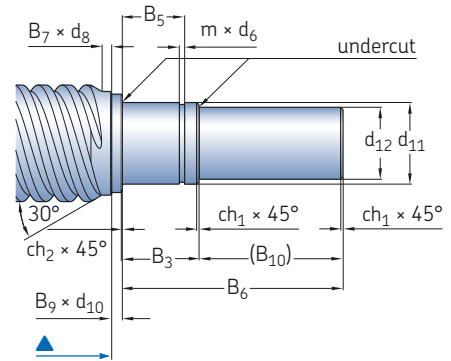

Type 5A

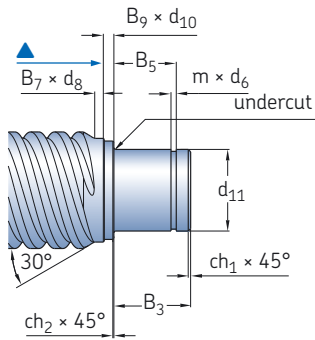

Type 4A

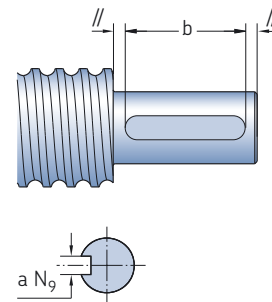

Keyway on request

Size		Keyway to DIN 6885									
$d_0 \times P_h$	G 6g	G_1	m +0,14 0	d_6 h11	h12	ch_1	ch_2	b_a	d_7 h11	$a^{N9} \times l \times b$	
										fixed end (type 2A)	fixed end (type 5A)
mm											
25×20	M17×1	22	1,1	16,2	–	0,5	0,5	1,5	15,5	A5×5×25	A5×5×25
25×25	M17×1	22	1,1	16,2	–	0,5	0,5	1,5	15,5	A5×5×25	A5×5×25
32×20	M20×1	22	1,1	16,2	–	0,5	0,5	1,5	18,5	A5×5×25	A5×5×25
32×32	M20×1	22	1,1	16,2	–	0,5	0,5	1,5	18,5	A5×5×25	A5×5×25
32×40	M20×1	22	1,1	16,2	–	0,5	0,5	1,5	18,5	A5×5×25	A5×5×25
40×20	M30×1,5	25	1,6	–	28,6	1	0,5	2,3	27,8	A8×7×40	A8×7×40
40×40	M30×1,5	25	1,6	–	28,6	1	0,5	2,3	27,8	A8×7×40	A8×7×40
50×50	M35×1,5	27	1,6	–	28,6	1	0,5	2,3	32,8	A8×7×45	A8×7×40

▲ End of threaded screw length

FLBU end bearings

Axially locating flanged housing with SKF angular contact ball bearings (back to back arrangement).

The “FLBU” flanged bearing unit consists of

- precision housing, made of burnished steel
- two SKF preloaded angular contact ball bearings, 72 or 73 series
- two garter seals
- locknut, self-locking Nylstop type or, on demand, high precision KMT.

The “FLBU” flanged thrust bearing unit provides the following benefits

- lubrication for life
- very easy mounting (matched bearings, hand mounting on the shaft end) as well as easy disassembly with the optional high precision KMT nut.

Note:

In standard version, the “FLBU” thrust bearing unit is assembled according to drawing page 43. If you require a different assembly, please indicate it when ordering.

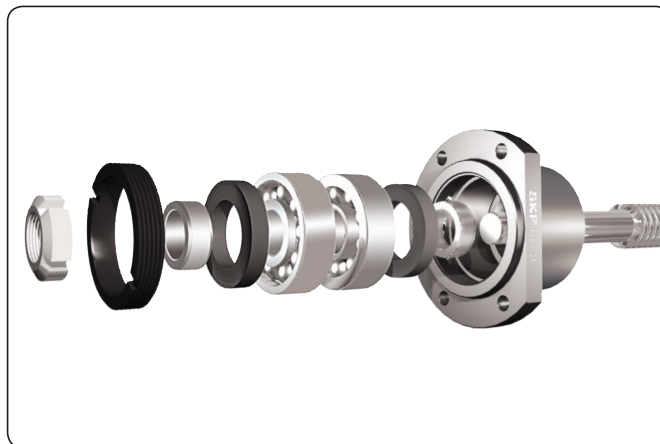
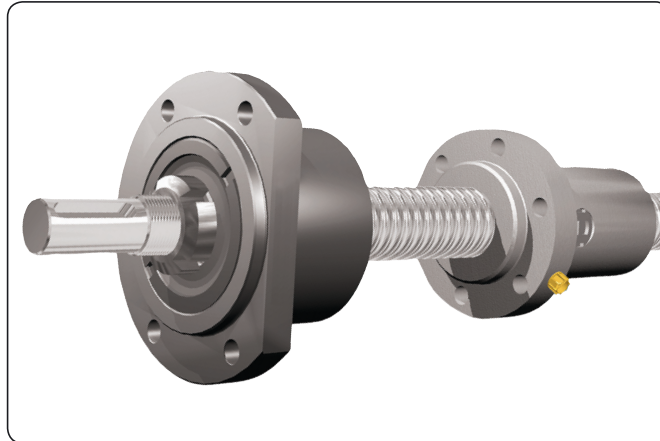

Nominal diameter	Angular contact ball bearing (40°)			SKF bearing designation	Lock nut		High precision nut ³⁾		Tightening torque	Grub screws size	tightening torque max.	Flanged bearing unit designation
	Basic load rating (axial) dynamic	static	Axial rigidity		Self-locking nut Designation	Hook spanner	Designation	Hook spanner				
d ₀	C _a	C _{0a}		–	–	–	–	–	Nm	–	Nm	–
16	12,2	12,8	play	7200 BECB ¹⁾	CN 70-10	HN 1	KMT 0	HN 2/3	4	M5	4,5	FLBU 16
20	13,3	14,7	125	7201 BEGA ²⁾	CN 70-12	HN 1	KMT 1	HN 3	8	M5	4,5	FLBU 20
25	27,9	31,9	150	7303 BEGA ²⁾	CN 70-17	HN3	KMT 3	HN 4	15	M6	8	FLBU 25
32	24,6	31,9	176	7204 BEGA ²⁾	CN 70-20	HN 4	KMT 4	HN 5	18	M6	8	FLBU 32
40	41,9	59,6	222	7206 BEGA ²⁾	CN 70-30	HN 6	KMT 6	HN 6	32	M6	8	FLBU 40
50	54,5	79,8	250	7207 BEGA ²⁾	CN 70-35	HN 7	KMT 7	HN 7	40	M6	8	FLBU 50
63	128	196,1	353	7310 BEGA ²⁾	CN 70-50	HN 10	KMT 10	HN 10/11	60	M8	18	FLBU 63

¹⁾ No backlash elimination

²⁾ Light preload

³⁾ Optional

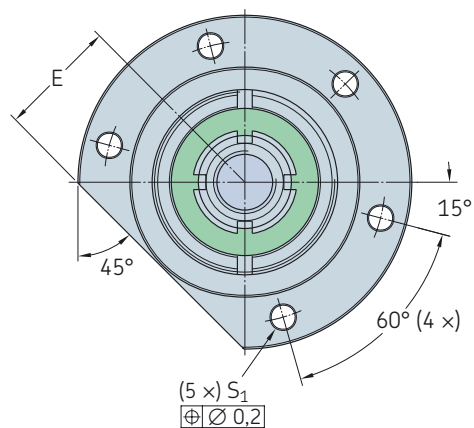
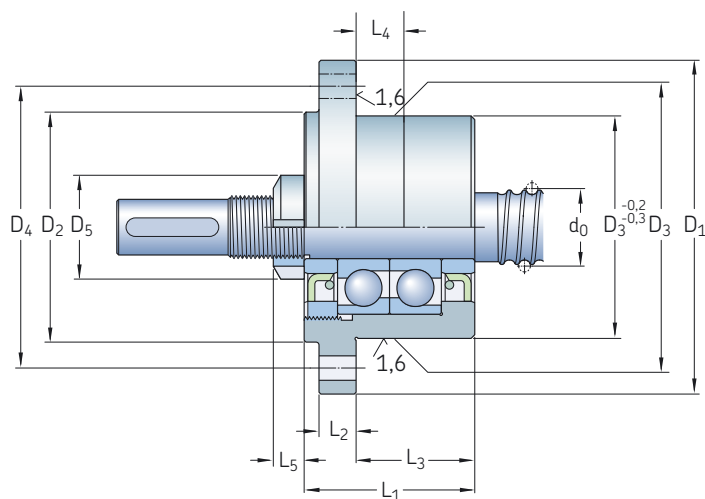

Screw End bearing

d ₀	L ₁	L ₂	L ₃	L ₄	Self-locking nut		High-precision nut			D ₂	D ₃ h7	D ₄	S ₁ H13	E	Fixing screws
					L ₅	D ₅	L ₅	D ₅	D ₁						
mm	mm														-
16	37	10	22	12	7	18	14	28	76	50	47	63	6,6	26	M6×30
20	42	10	25	12	7,5	21	14	30	76	50	47	63	6,6	27	M6×30
25	46	10	32	18	8,3	28	18	37	90	62	60	76	6,6	32	M6×30
32	49	13	32	18	8,3	32	18	40	90	59	60	74	9	32	M8×40
40	53	16	32	18	11	44	20	49	120	80	80	100	11	44	M10×45
50	59	20	32	18	11	50	22	54	130	89	90	110	13	49	M12×60
63	85	25	43,5	22	11,7	68	25	75	165	124	124	146	13	64	M12×60

PLBU end bearings

Fixed plummer housing with SKF angular contact ball bearings (back to back arrangement)

The “PLBU” plummer bearing unit consists of:

- precision housing, made of burnished steel, with precision reference edges on both sides
- two SKF preloaded angular contact ball bearings, 72 or 73 series
- two garter seals
- locknut, self-locking Nylstop type or, on demand, high precision KMT.

The “PLBU” plummer bearing unit provides the following benefits:

- lubrication for life.
- very easy mounting (matched bearing, hand mounting on the shaft ends) as well as easy disassembly with the optional high precision KMT nut.
- good rigidity guaranteed by foot mounting with dowel pins.

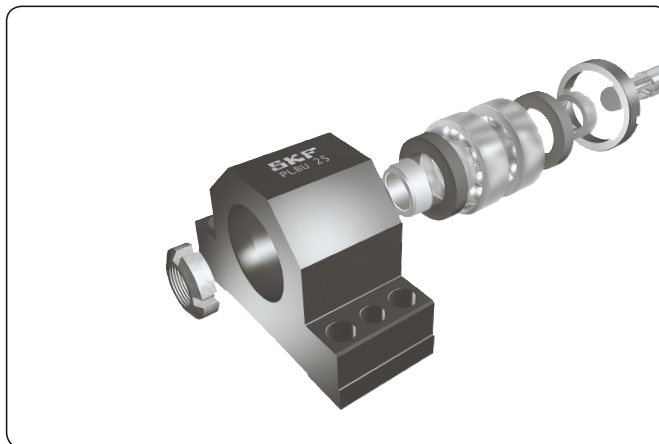
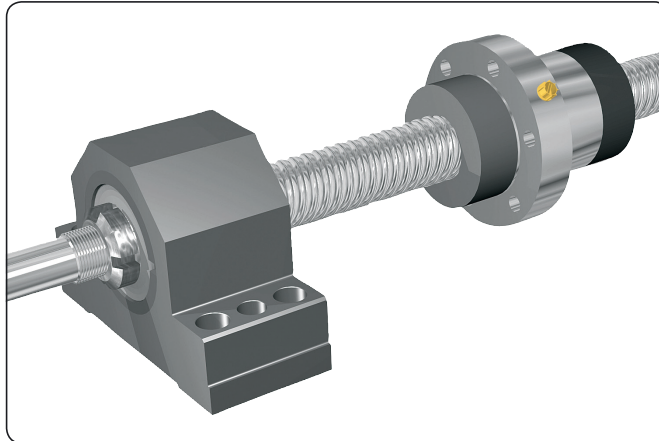

Nominal diameter	Angular contact ball bearing (40°)			SKF bearing designation	Lock nut		High precision nut ³⁾		Tightening torque	Grub screws size	tightening torque max.	Flanged bearing unit designation
	Basic load rating (axial) dynamic	static	Axial rigidity		Self-locking nut Designation	Hook spanner	Designation	Hook spanner				
d ₀	C _a	C _{0a}		–	–	–	–	–	Nm	–	Nm	–
16	12,2	12,8	play	7200 BECB ¹⁾	CN 70-10	HN 1	KMT 0	HN 2/3	4	M5	4,5	PLBU 16
20	13,3	14,7	125	7201 BEGA ²⁾	CN 70-12	HN 1	KMT 1	HN 3	8	M5	4,5	PLBU 20
25	27,9	31,9	150	7303 BEGA ²⁾	CN 70-17	HN3	KMT 3	HN 4	15	M6	8	PLBU 25
32	24,6	31,9	176	7204 BEGA ²⁾	CN 70-20	HN 4	KMT 4	HN 5	18	M6	8	PLBU 32
40	41,9	59,6	222	7206 BEGA ²⁾	CN 70-30	HN 6	KMT 6	HN 6	32	M6	8	PLBU 40
50	54,5	79,8	250	7207 BEGA ²⁾	CN 70-35	HN 7	KMT 7	HN 7	40	M6	8	PLBU 50
63	128	196,1	353	7310 BEGA ²⁾	CN 70-50	HN 10	KMT 10	HN 10/11	60	M8	18	PLBU 63

¹⁾ No backlash elimination

²⁾ Light preload

³⁾ Optional

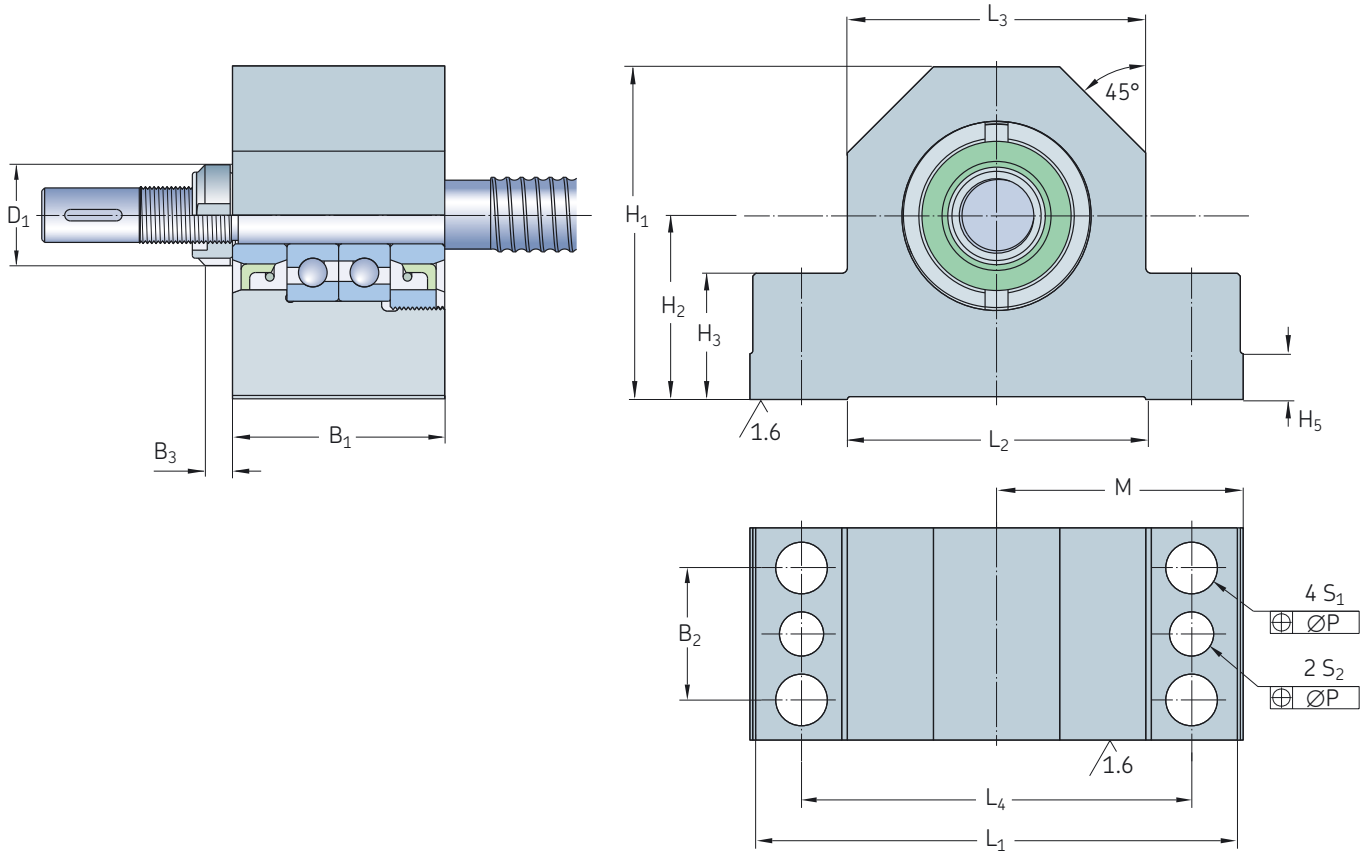

Screw End bearing

d ₀	L ₁	L ₂	L ₃	L ₄	M	B ₁	B ₂	Self-locking nut B ₃	D ₁	High precision nut ⁴⁾ B ₃	D ₁	H ₁	H ₂ js8	H ₃	H ₄	H ₅	S ₁	P	S ₂ H12	Fixing screws	Tapered pin (hardened) or straight pin (DIN6325)	
mm	mm																					
16	86	52	52	68	43	37	23	7,0	18	14	28	58	32	22	15	8	9	0,15	7,7	M8×35	8×40	
20	94	52	60	77	47	42	25	7,5	21	14	30	64	34	22	17	8	9	0,15	7,7	M8×35	8×40	
25	108	65	66	88	54	46	29	8,3	28	18	37	72	39	27	19	10	11	0,20	9,7	M10×40	10×50	
32	112	65	70	92	56	49	29	8,3	32	18	40	77	45	27	20	10	11	0,20	9,7	M10×40	10×50	
40	126	82	80	105	63	53	32	11,0	44	20	49	98	58	32	23	12	13	0,20	9,7	M12×50	10×50	
50	144	80	92	118	72	59	35	11,0	50	22	54	112	65	38	25	12	13	0,20	9,7	M12×55	10×55	
63	190	110	130	160	95	85	40	11,7	68	25	75	130	65	49	35	15	13	0,20	9,7	M12×65	10×65	

⁴⁾ optional

BUF end bearings

Axially free plummer housing with SKF deep-groove ball bearing

The “BUF” plummer bearing unit consists of

- precision housing made of burnished steel, with one reference side
- grease-tight deep-groove SKF ball bearing, greased for life, type 62.. 2RS1
- retaining ring.

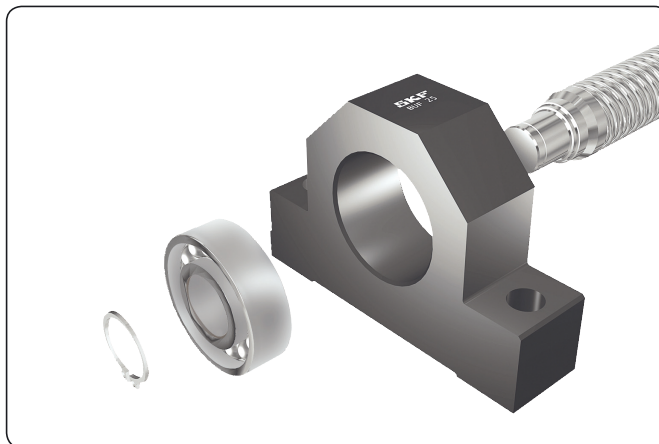
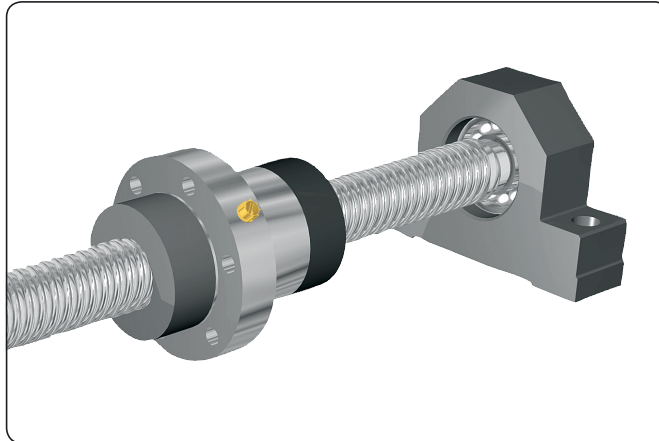

Nominal diameter	Deep-groove ball bearing		SKF bearing designation	Dimensions			Retaining ring (DIN 471)	Plummer bearing unit designation (free)
	Basic load rating radial			d	D	B		
d_0	C	C_0	–	mm	mm	mm	–	–
mm	kN	kN	–	mm	mm	mm	–	–
16	5,07	2,36	6200.2RS1	10	30	9	10×1	BUF 16
20	5,07	2,36	6200.2RS1	10	30	9	10×1	BUF 20
25	9,56	4,75	6203.2RS1	17	40	12	17×1	BUF 25
32	9,56	4,75	6203.2RS1	17	40	12	17×1	BUF 32
40	19,5	11,2	6206.2RS1	30	62	16	30×1,5	BUF 40
50	19,5	11,2	6206.2RS1	30	62	16	30×1,5	BUF 50
63	33,2	21,6	6209.2RS1	45	85	19	45×1,75	BUF 63

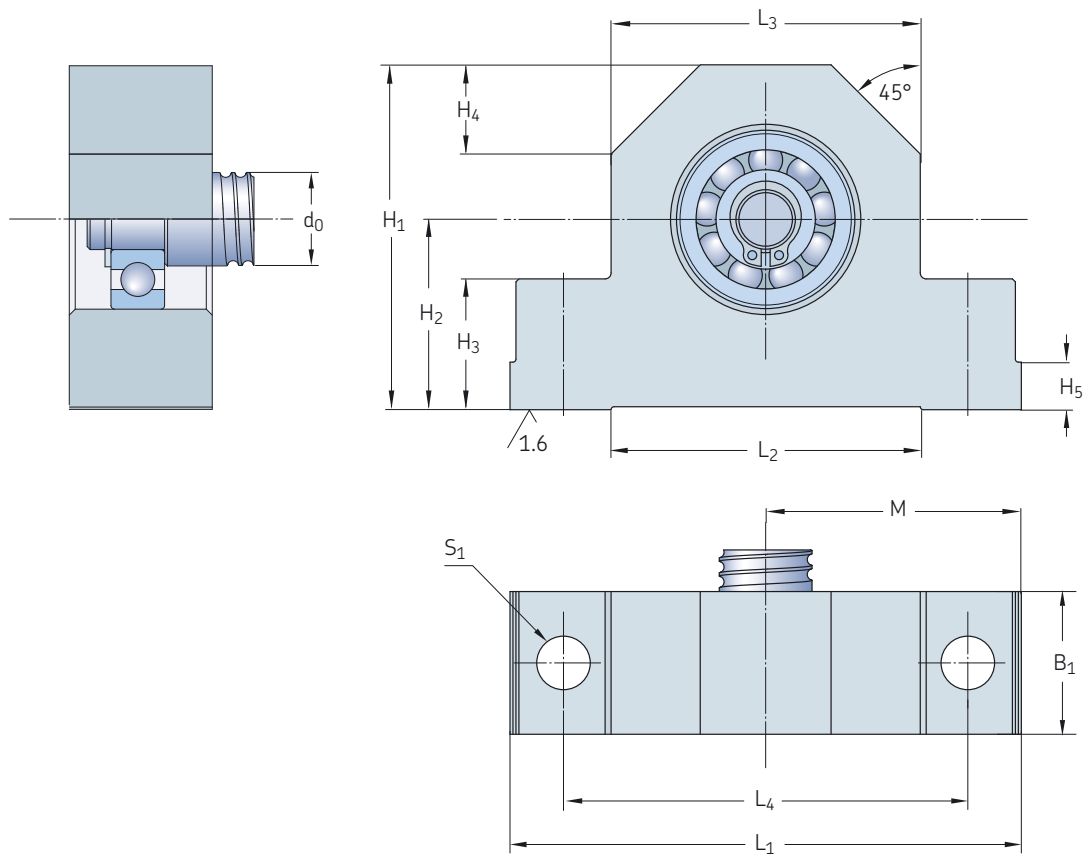

D

Screw End bearing

d ₀	L ₁	L ₂	L ₃	L ₄	M js8	B ₁	H ₁	H ₂ js8	H ₃	H ₄	H ₅	S ₁ H12	Fixing screws
													-
16	86	52	52	68	43	24	58	32	22	15	8	9	M8×35
20	94	52	60	77	47	26	64	34	22	17	8	9	M8×35
25	108	65	66	88	54	28	72	39	27	19	10	11	M10×40
32	112	65	70	92	56	34	77	45	27	20	10	11	M10×40
40	126	82	80	105	63	38	98	58	32	23	12	13	M12×50
50	144	80	92	118	72	39	112	65	38	25	12	13	M12×55
63	190	110	130	160	95	38	130	65	49	35	15	13	M12×65

Calculation formulae

Basic life rating

$$L_{10} = \left(\frac{C_a}{F_m} \right)^3$$

Basic load rating

$$C_{req} = F_m (L_{10})^{1/3}_{req}$$

where

L_{10} = life [million revolutions]

C_a = basic dynamic load rating [N]

C_{req} = required dynamic load rating [N]

F_m = cubic mean load [N]

Cubic mean load

$$F_m = \frac{(F_1^3 L_1 + F_2^3 L_2 + F_3^3 L_3 + \dots)^{1/3}}{(L_1 + L_2 + L_3 + \dots)^{1/3}}$$

where

L_n = load period n (→ fig. 12)

F_n = average load during period n
(→ fig. 12)

$$F_m = \frac{F_{min} + 2F_{max}}{3}$$

where

F_{min} = minimum load (→ diagram 2)

F_{max} = maximum load (→ diagram 2)

Critical speed of screw shaft (no safety factor)

$$n_{cr} = 49 \times 10^6 \frac{f_1 d_2}{l^2}$$

where

n_{cr} = critical speed [rpm]

d_2 = root diameter [mm]

l = free length, or distance between the two support bearings [mm]

f_1 = mounting correction factor

0,9 ●● — fixed, free

3,8 ●● — fixed, supported

5,6 ●● — fixed, fixed

Note: a safety factor of 0,8 is generally recommended.

Speed limit of the mechanism (maximal speed applied through very short periods)

With recirculation by tubes/inserts (SH/SHS/SD/SDS/BD/BDS-SX/BX-SN/BN/PN-SND/BND/PND):

$$n d_0 < 50\,000$$

With recirculation through flange (SL/TL-SLD/TLD):

$$n d_0 < 90\,000$$

If $n d_0 > 50\,000$ or $90\,000$ respectively, consult SKF.

where

n = rotational speed [rpm]

d_0 = screw shaft nominal diameter [mm]

Maximum admissible acceleration is $4\,000 \text{ rad/s}^2$

Buckling strength, with safety factor 3

$$F_c = \frac{34 \times 10^3 f_3 d_2^4}{l^2}$$

where

F_c = buckling strength [N]

d_2 = root diameter [mm]

l = free length, or distance between the two support bearings [mm]

f_3 = mounting correction factor

0,25 ●● — fixed, free

1 ●● — supported, supported

2 ●● — fixed, supported

4 ●● — fixed, fixed

Fig. 12

Cubic mean load

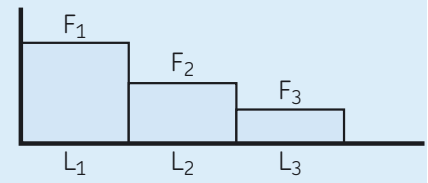
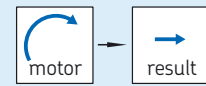

Diagram 2

Cubic mean load

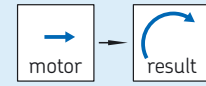

Fig. 13



Rotation Translation

Fig. 14



Translation Rotation

Theoretical efficiencies

direct (→ fig. 13)

$$\eta = \frac{1}{1 + \frac{\pi d_0}{P_h} \mu}$$

where

$\mu = 0,0065$ for SH/SHS

$\mu = 0,006$ for SD/SDS, BD/BDS, SX, SL, SN, SND, BX, BN, TL, PN, PND

d_0 = nominal diameter of screw shaft [mm]

P_h = lead [mm]

indirect (→ fig. 14)

$$\eta' = 2 - \frac{1}{\eta}$$

Practical efficiency

$$\eta_p = 0,9 \eta$$

The value 0,9 used is an average value between the practical efficiency of a new screw and that of a properly run in screw. It should be used for industrial applications in all normal working conditions. For extreme cases, call us.

Input torque in a steady state

$$T = \frac{F P_h}{2\,000 \pi \eta_p}$$

where

T = input torque [Nm]

F = maximum load of the cycle [N]

P_h = lead [mm]

η_p = practical efficiency

Power required in a steady state

$$P = \frac{F n P_h}{60\,000 \eta_p}$$

where

P = power required [W]

n = revolutions per minute [rpm]

Preload torque [Nm]

$$T_{pr} = \frac{F_{pr} P_h}{1\,000 \pi} \left(\frac{1}{\eta_p} - 1 \right)$$

where

T_{pr} = preload torque [Nm]

F_{pr} = preload [N]

Restraining torque (considering system backdriving)

$$T_B = \frac{F P_h \eta'}{2\,000 \pi}$$

where

T_B = restraining torque [Nm]

F = load [N]

For safety, we use the theoretical indirect efficiency.

Nominal motor torque when accelerating

For a horizontal screw

$$T_t = T_f + T_{pr} + \frac{P_h [F + m_L \mu_f g]}{2\,000 \pi \eta_p} + \dot{\omega} \Sigma I$$

For a vertical screw

$$T_t = T_f + T_{pr} + \frac{P_h [F + m_L g]}{2\,000 \pi \eta_p} + \dot{\omega} \Sigma I$$

where

T_t = nominal torque [Nm]

T_f = torque from friction in support bearings, motors, seals, etc... [Nm]

T_{pr} = preload torque [Nm]

μ_f = coefficient of friction

$\dot{\omega}$ = angular acceleration [rad/s²]

m_L = mass of the load [kg]

g = acceleration of gravity [9,8 m/s²]

$\Sigma I = I_M + I_L + I_S \cdot l \cdot 10^{-9}$

Nominal braking torque when decelerating

For a horizontal screw

$$T'_t = T_f + T_{pr} + \frac{P_h \eta' [F + m_L \mu_f g]}{2\,000 \pi} + \dot{\omega} \Sigma I$$

For a vertical screw

$$T'_t = T_f + T_{pr} + \frac{P_h \eta' [F + m_L g]}{2\,000 \pi} + \dot{\omega} \Sigma I$$

where

$$I_L = m_L \left(\frac{P_h}{2 \pi} \right)^2 10^{-6}$$

where

I_M = inertia of motor [kgm²]

I_S = inertia of screw shaft per metre [kgmm²/m]

l = length of screw shaft [mm]

Static axial stiffness

$$\frac{1}{R_t} = \frac{1}{R_s} + \frac{1}{R_n} + \frac{1}{R_p}$$

Fix-free or fix-support

$$R_s = 165 \frac{d_2^2}{l}$$

Fix-fix assembly

$$R_s = \frac{165 d_2^2 l}{l_2 (l - l_2)}$$

where

R_s = shaft rigidity [N/μm]

R_n = nut rigidity [N/μm]

R_p = end bearing rigidity [N/μm]

For details see **page 10**.

For additional information, please contact SKF

Designation

SN 32 x R5 330/445 G7 L - HA + K **/** WPR

Nut type

- SD = Miniature screw, axial play, internal recirculation nut
- SDS = Miniature screw, axial play, stainless steel
- BD = Miniature screw, backlash elimination by oversize balls
- BDS = Miniature screw, backlash elimination, stainless steel
- SH = Miniature screw, axial play, recirculation by integrated tube
- SHS = Miniature screw, axial play, stainless steel
- SX = Universal screw, axial play
- BX = Universal screw, backlash elimination by oversize balls
- SN = Precision screw, axial play
- BN = Precision screw, backlash elimination by oversize balls
- SND = Precision screw, axial play, DIN nut
- BND = Precision screw, backlash elimination by oversize balls, DIN nut
- PN = Precision screw with optimal rigidity
- PND = Precision screw with optimal rigidity, DIN nut
- SL = Long lead screw, axial play
- SLD = Long lead screw, axial play, DIN nut
- TL = Long lead screw, backlash elimination
- TLD = Long lead screw, backlash elimination, DIN nut
- SLT = Rotating nut with axial play
- TLT = Rotating nut with backlash elimination

Nominal diameter x Lead

Hand

R = Right, L = Left (on request)

Threaded length/Total length, mm

Lead precision: G9, G7, G5

Nut orientation

Threaded side or flange of nut towards shorter (S) or longer (L) machined end of shaft. In case of same end machining : (-)

Machined end combination

See page 36

Required lengths for: AA-SA-UA (both sides)

See page 36

WPR: with wipers • NOWPR: without • RING: safety ring (for SH-SD only)

REDPLAY :

Reduced axial play

Roller screws and electromechanical cylinders

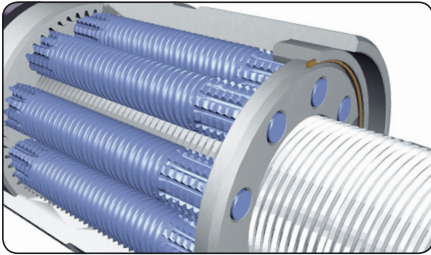

Planetary roller screws:

The robust screws for long life in tough conditions.

$D = 8$ to 210 mm

$P_h = 4$ to 42 mm

- high load carrying capacity
- ability to survive occasional blows and shock loads
- highly reliable, even in hostile surroundings and at high rotational speed.

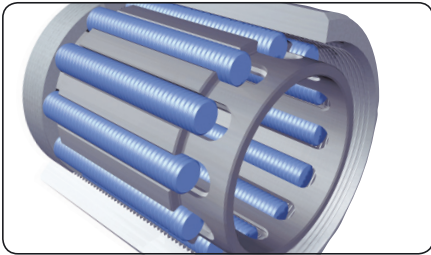

Recirculating roller screws:

The fine screws for ultimate positioning accuracy.

$D = 8$ to 125 mm

$P_h = 1$ to 5 mm

- fine resolution
- high rigidity

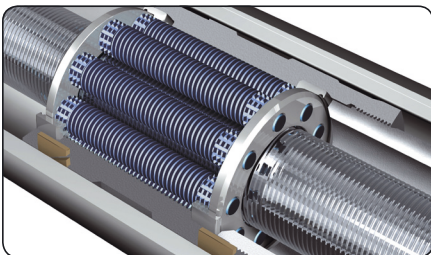

Electromechanical cylinders:

The high performance Electromechanical cylinders consist of an SKF planetary roller screw directly driven through a coupling by a brushless motor. The roller screw converts rotary motion into linear movement.

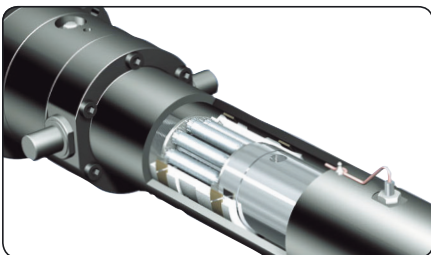

They are designed for long life, high acceleration and high force applications. The cylinders use brushless servomotor technology, with an in-line direct drive as standard. SKF high performance electromechanical cylinders using planetary roller screws are expanding the limits of linear actuators.

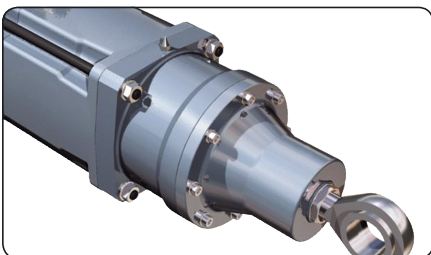

The new standard for high performance motion:

Compact Electromechanical cylinders (CEMC) are designed to deliver the combination of a dynamic flexible actuation packaged with powerful performance.

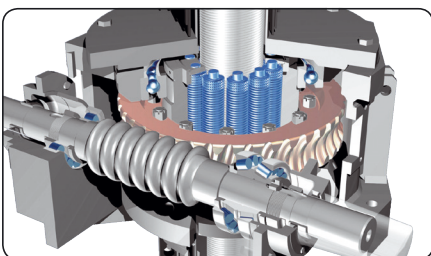

Cylinders for heavy loads:

High loads and heavy working cycles: long life in adverse environments such as in steel industry.



© SKF is a registered trademark of the SKF Group.

© SKF Group 2009

The contents of this publication are the copyright of the publisher and may not be reproduced (even extracts) unless prior written permission is granted. Every care has been taken to ensure the accuracy of the information contained in this publication but no liability can be accepted for any loss or damage whether direct, indirect or consequential arising out of the use of the information contained herein. Previous catalogues, in which the data deviate from those given here, are rendered invalid. The right is reserved to make changes necessitated by technological developments.

Publication **6971 EN** · April 2009

This publication supersedes publication 4141.

Printed in France on environmentally friendly paper.

Certain images used under license from Shutterstock.com