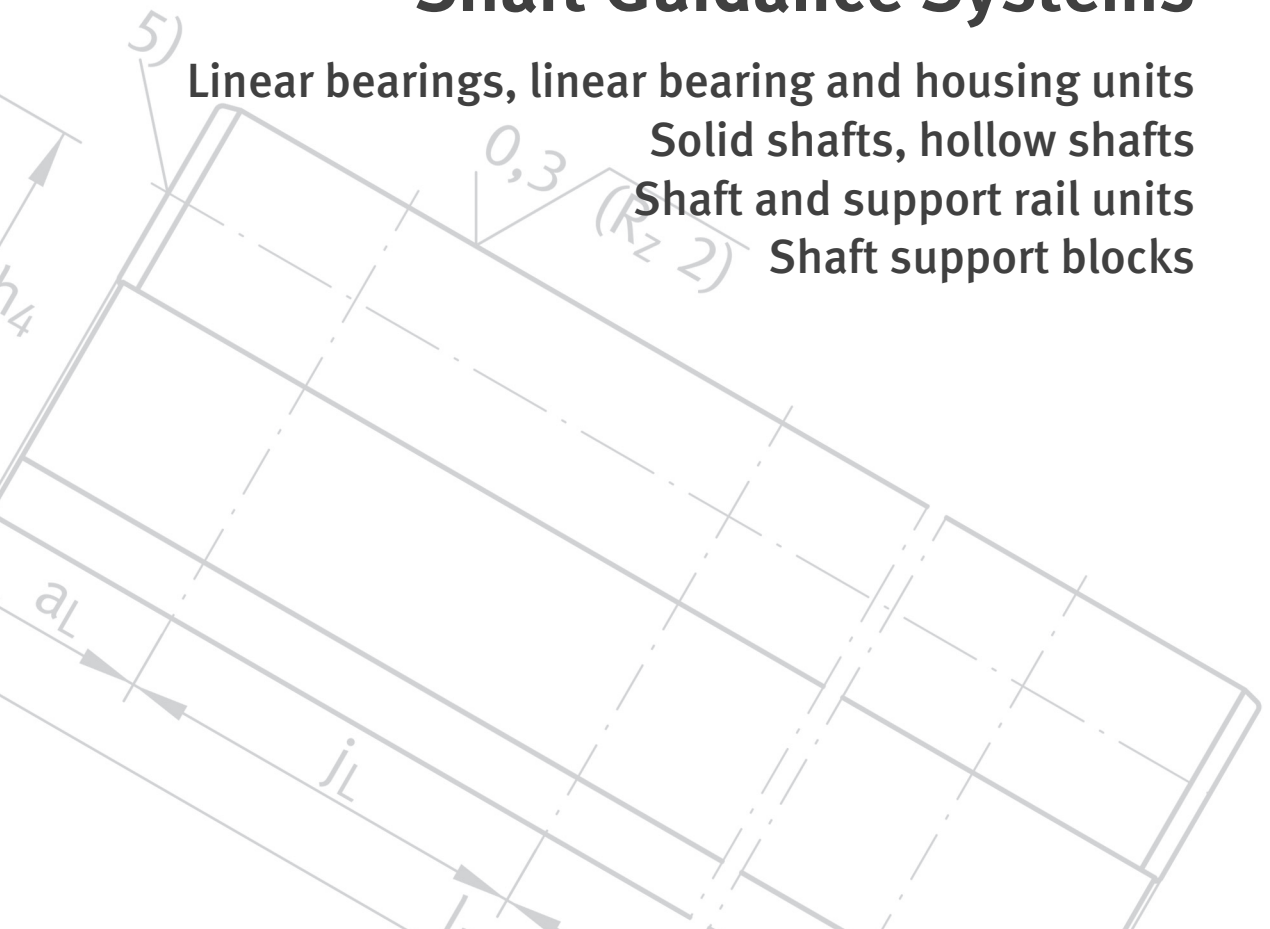


Shaft Guidance Systems

- Linear bearings, linear bearing and housing units
- Solid shafts, hollow shafts
- Shaft and support rail units
- Shaft support blocks



All data have been prepared with a great deal of care and checked for their accuracy but no liability can be accepted for any errors or omissions. We reserve the right to make technical modifications.

© Schaeffler KG · 2008, January

Reproduction in whole or in part without our authorisation is prohibited.

Foreword

Shaft guidance systems comprise shafts or shaft and support rail units combined with low-friction linear ball bearings or Permaglide® plain bearings. The shafts can be either solid or hollow shafts, while shaft and support rail units are always solid. For ease of fixing to the adjacent construction, the guidance systems are also available as complete linear bearing and housing units.

Economical due to modular concept

The complete range, structured according to a modular concept, allows particularly application-oriented, technically up-to-date and highly economical linear bearing guidance systems with a long, maintenance-free operating life.

Bearings and units are available in the compact, light, heavy duty, machined and Permaglide® plain bearing range. Each series has highly specific characteristics that precisely define it as suitable for particular applications.

Linear bearings

Linear ball bearings can support high radial loads while having a relatively low mass and allow the construction of linear guidance systems with unlimited travel. The bearings are available in closed versions and with a segment cutout for supported shafts. In some series, the radial clearance can be adjusted. This makes it possible to achieve clearance-free or preloaded guidance systems. Depending on the application, the linear bearings are either unsealed or are fitted with contact seals on both sides.

Linear bearing and housing units

In the linear bearing and housing units, the bearing is integrated in a strong, rigid housing. The housings are available in closed, open, slotted and tandem versions. Due to their low total mass, the units are particularly suitable for reduced mass designs with high loads and where higher accelerations and travel speeds are required. As a result of volume production in large quantities, the complete units are normally considerably more economical than customers' own designs.

Replacement for ...

The new catalogue replaces the section on shaft guidance systems in Catalogue 801 from the Schaeffler Group. The data in the catalogue represent the current level of technology and manufacture as of January 2008. They reflect not only progress in rolling bearing technology but also the experience gathered in practical use.

Data in earlier catalogues as well as in Product and Market Information publications that do not correspond to the data in this catalogue are therefore invalid.

Safety guidelines and symbols

High product safety

Our products correspond to the current level of research and technology. If the bearing arrangement is correctly designed, if the products are handled and fitted correctly and as agreed and if they are maintained as instructed, they do not give rise to any immediate hazards.

Statements to be observed

This publication gives descriptions of standard products. Since these are used in numerous applications, we cannot make a judgement as to whether any malfunctions will cause harm to persons or property.

It is always and fundamentally the responsibility of the designer and user to ensure that all specifications are observed and that all necessary safety information is communicated to the end user. This applies in particular to applications in which product failure and malfunction may endanger persons.

Definition of guidelines and symbols

The warning and hazard symbols are defined along the lines of ANSI Z535.6–2006.

The meaning of the guidelines and symbols is as follows.

If they are not observed, minor or slight injury will occur.

Caution 

Attention!

If they are not observed, damage or malfunctions in the product or the adjacent construction will occur.

Note!

There follows additional or more detailed information that must be observed.

①

Numbers within a circle are item numbers.

Contents

	Page
Safety guidelines and symbols	4
Product index	6
Product overview	10
Shaft guidance systems	
Technical principles	12
Linear bearings and linear bearing and housing units	42
Solid shafts, hollow shafts	118
Shaft and support rail units	142
Shaft support blocks	160
Addresses	171

Product index

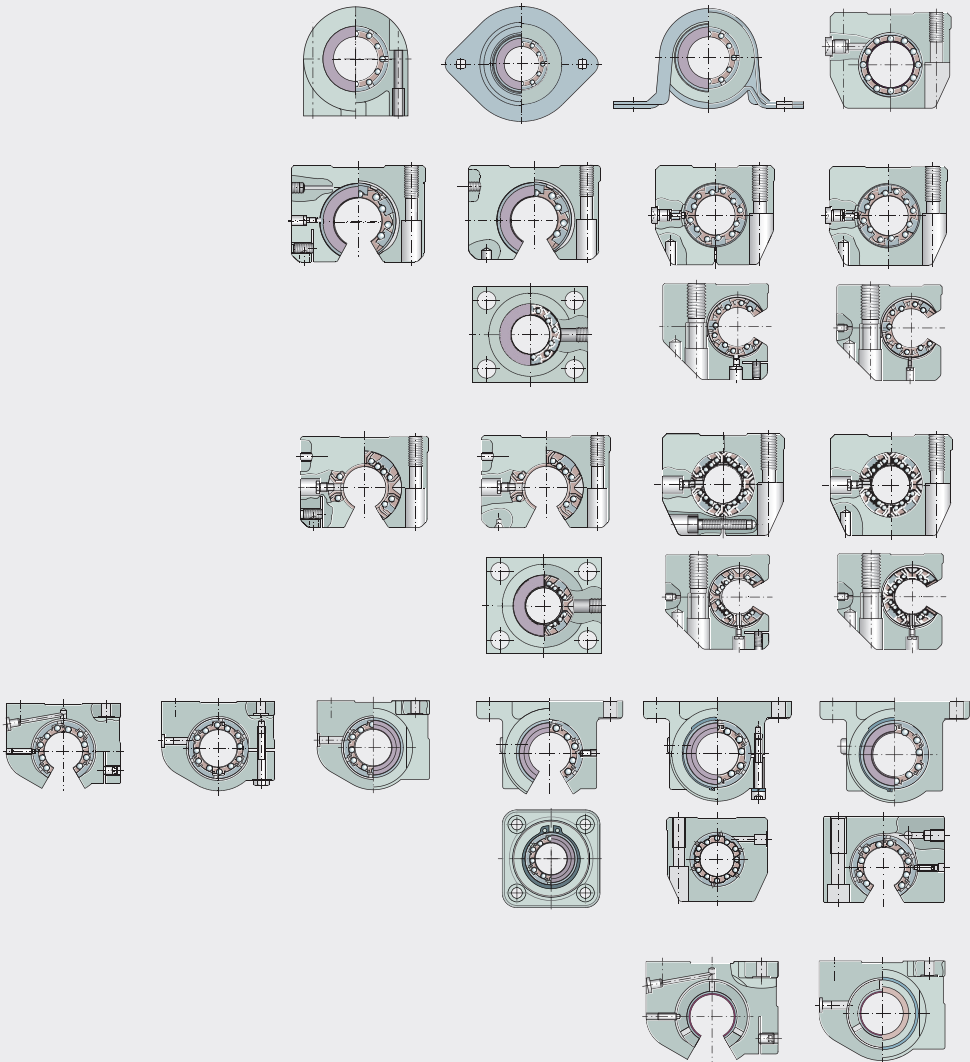
	Page
KH	Linear ball bearing, compact range 46
KGHA..-PP	Linear ball bearing and housing unit, compact range, closed, sealed 46
KGHK..-B-PP-AS	Linear ball bearing and housing unit, compact range, closed, sealed, relubrication facility..... 46
KGHW..-PP	Linear ball bearing and housing unit, compact range, sheet steel housing, with Corrotect® coating, sealed 46
KGHWT..-PP	Linear ball bearing and housing unit, compact range, sheet steel housing, with Corrotect® coating, sealed 46
KTHK..-B-PP-AS	Linear ball bearing and housing unit, compact range, closed, bearings in tandem arrangement, sealed, relubrication facility..... 46
KN..-B	Linear ball bearing, light range, closed, self-aligning 47
KNO..-B	Linear ball bearing, light range, segment cutout, self-aligning..... 47
KGN..-C-PP-AS	Linear ball bearing and housing unit, light range, closed, sealed, relubrication facility..... 47
KGNC..-C-PP-AS	Linear ball bearing and housing unit, light range, segment cutout, sealed, relubrication facility..... 47
KGNCs..-C-PP-AS	Linear ball bearing and housing unit, light range, slotted housing, segment cutout, sealed, relubrication facility..... 47
KGNO..-C-PP-AS	Linear ball bearing and housing unit, light range, segment cutout, sealed, relubrication facility..... 47
KGNOs..-C-PP-AS	Linear ball bearing and housing unit, light range, slotted housing, segment cutout, sealed, relubrication facility..... 47
KGNS..-C-PP-AS	Linear ball bearing and housing unit, light range, closed, slotted housing, sealed, relubrication facility 47
KTFN..-C-PP-AS	Linear ball bearing and housing unit, light range, closed, bearings in tandem arrangement, with centring flange, sealed, relubrication facility 47
KTN..-C-PP-AS	Linear ball bearing and housing unit, light range, closed, bearings in tandem arrangement, sealed, relubrication facility..... 47
KTNO..-C-PP-AS	Linear ball bearing and housing unit, light range, bearings in tandem arrangement, segment cutout, sealed, relubrication facility..... 47
KTNOs..-C-PP-AS	Linear ball bearing and housing unit, light range, bearings in tandem arrangement, segment cutout, slotted housing, sealed, relubrication facility..... 47
KTNS..-C-PP-AS	Linear ball bearing and housing unit, light range, closed, bearings in tandem arrangement, slotted housing, sealed, relubrication facility..... 47

	Page
KS Linear ball bearing, heavy duty range, closed, self-aligning	48
KSO Linear ball bearing, heavy duty range, segment cutout, self-aligning	48
KGSC...-PP-AS Linear ball bearing and housing unit, heavy duty range, segment cutout, sealed, relubrication facility	48
KGSCS...-PP-AS Linear ball bearing and housing unit, heavy duty range, segment cutout, slotted housing, sealed, relubrication facility	48
KGSNG...-PP-AS Linear ball bearing and housing unit, heavy duty range, closed, sealed, relubrication facility	48
KGSNO...-PP-AS Linear ball bearing and housing unit, heavy duty range, segment cutout, sealed, relubrication facility	48
KGSNOS...-PP-AS Linear ball bearing and housing unit, heavy duty range, segment cutout, slotted housing, sealed, relubrication facility	48
KGSNS...-PP-AS Linear ball bearing and housing unit, heavy duty range, slotted housing, sealed, relubrication facility	48
KTFS Linear ball bearing and housing unit, heavy duty range, closed, bearings in tandem arrangement, with centring flange, sealed, relubrication facility	48
KTSG...-PP-AS Linear ball bearing and housing unit, heavy duty range, closed, bearings in tandem arrangement, sealed, relubrication facility	48
KTSO...-PP-AS Linear ball bearing and housing unit, heavy duty range, bearings in tandem arrangement, segment cutout, sealed, relubrication facility	48
KTSOS...-PP-AS Linear ball bearing and housing unit, heavy duty range, bearings in tandem arrangement, segment cutout, slotted housing, sealed, relubrication facility	48
KTSS...-PP-AS Linear ball bearing and housing unit, heavy duty range, closed, bearings in tandem arrangement, slotted housing, sealed, relubrication facility	48

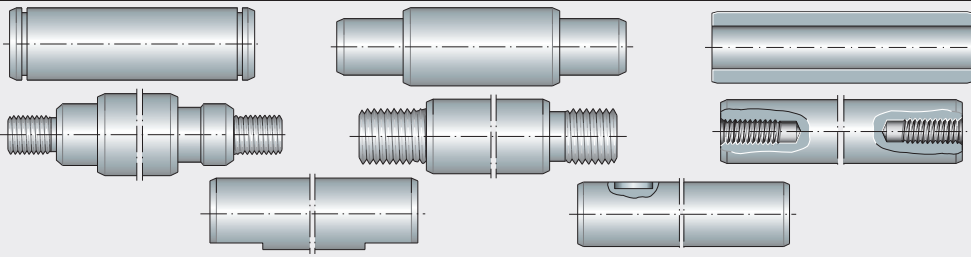
Product index

	Page
KB Linear ball bearing, machined range, closed.....	49
KBO Linear ball bearing, machined range, closed, segment cutout	49
KBS Linear ball bearing, machined range, slotted	49
KFB..-PP-AS Linear ball bearing and housing unit, machined range, closed, with flange, sealed, relubrication facility.....	50
KGB..-PP-AS Linear ball bearing and housing unit, machined range, closed, sealed, relubrication facility.....	49
KGBA..-PP-AS Linear ball bearing and housing unit, machined range, closed, sealed, relubrication facility.....	49
KGBAO..-PP-AS Linear ball bearing and housing unit, machined range, segment cutout, sealed, relubrication facility.....	49
KGBAS..-PP-AS Linear ball bearing and housing unit, machined range, slotted housing, sealed, relubrication facility.....	49
KGBO..-PP-AS Linear ball bearing and housing unit, machined range, segment cutout, sealed, relubrication facility.....	49
KGBS..-PP-AS Linear ball bearing and housing unit, machined range, slotted housing, sealed, relubrication facility.....	49
KTB..-PP-AS Linear ball bearing and housing unit, machined range, closed, bearings in tandem arrangement, sealed, relubrication facility.....	49
KTBO..-PP-AS Linear ball bearing and housing unit, machined range, segment cutout, bearings in tandem arrangement, sealed, relubrication facility.....	49

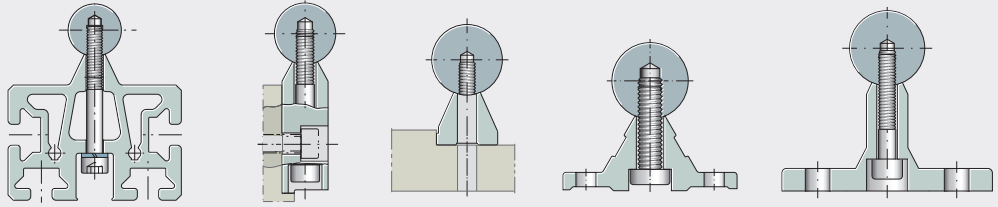
	Page
PAB...-PP-AS	Linear plain bearing, Permaglide® plain bearing range, closed, sealed, relubrication facility 51
PABO...-PP-AS	Linear plain bearing, Permaglide® plain bearing range, segment cutout, sealed, relubrication facility 51
PAGBA...-PP-AS	Linear plain bearing unit, Permaglide® plain bearing range, closed, sealed, relubrication facility 51
PAGBAO...-PP-AS	Linear plain bearing unit, Permaglide® plain bearing range, segment cutout, sealed, relubrication facility 51
W	Solid shafts..... 122
WH	Hollow shafts 122
TSMW	Shaft and support rail unit, support rail with high bending rigidity 146
TSNW	Shaft and support rail unit for fixing from above 146
TSNW..-G4	Shaft and support rail unit for fixing from above 146
TSNW..-G5	Shaft and support rail unit for fixing from above 146
TSSW	Shaft and support rail unit for fixing from side..... 146
TSUW	Shaft and support rail unit for fixing from below 146
TSWW	Shaft and support rail unit for fixing from above 146
TSWWA	Shaft and support rail unit for fixing from above 146
FW	Shaft support block with flange 164
GW	Shaft support block..... 164
GWA	Shaft support block..... 164
GWH	Shaft support block..... 164
GWN	Shaft support block..... 164



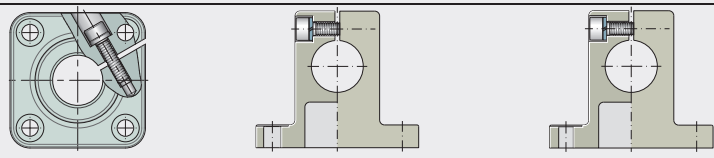
120 584a



120 586



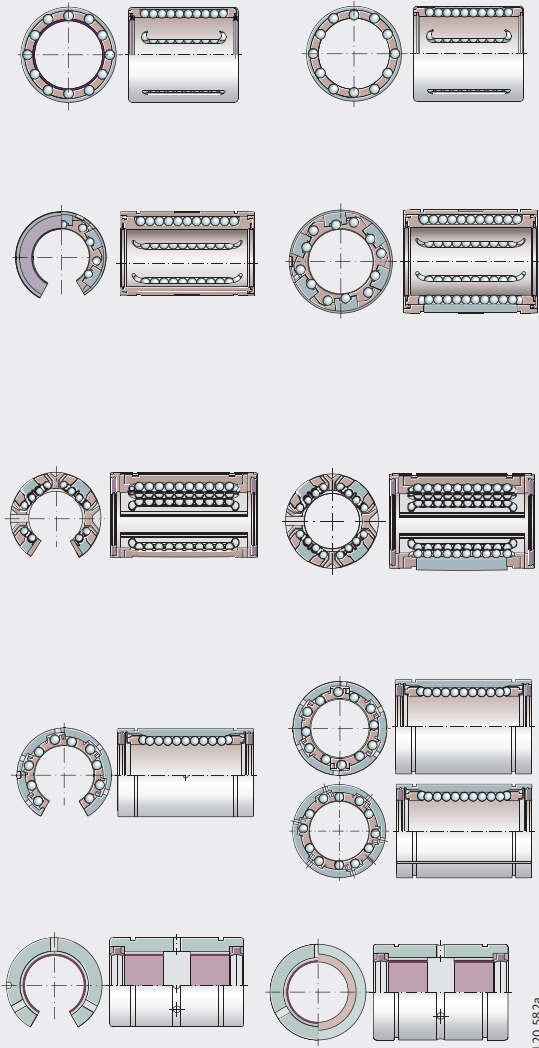
120 588



120 590

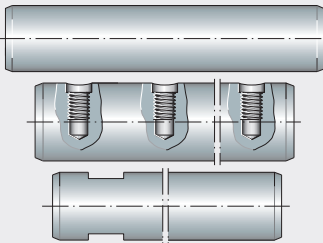
**Linear bearings and
linear bearing and housing units**

- Compact range
- Light range
- Heavy duty range
- Machined range
- Permaglide® plain bearing range



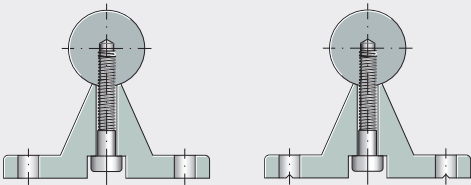
120 582a

**Solid shafts
Hollow shafts**



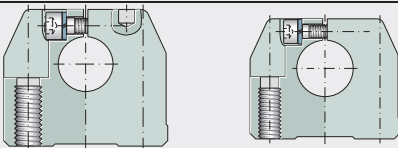
120 585

Shaft and support rail units

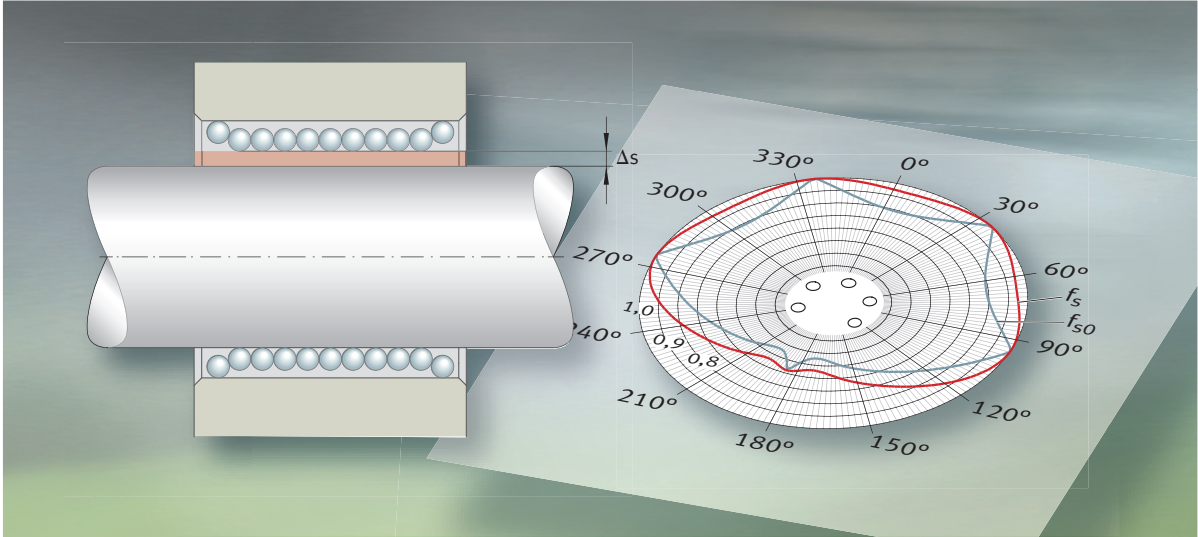


120 587

Shaft support blocks



120 589



Technical principles

Load carrying capacity and life

Friction

Lubrication

Design of bearing arrangements

Operating clearance

Fitting



Technical principles

	Page	
Load carrying capacity and life	Basic rating life 15	
	Operating life 16	
	Static load safety factor..... 16	
	Influence of the shaft raceway on basic load ratings..... 17	
	Differences in raceway hardness..... 17	
	Load direction and position of the ball rows 18	
	Main load direction..... 18	
	Linear ball bearings 19	
	Linear ball bearing and housing units 19	
	Misalignment of the shaft..... 25	
	Load factors in misalignment..... 25	
	Compensation of misalignments in the light and heavy duty range 26	
	Friction	Coefficient of friction 27
		Coefficient of friction in unsealed bearings 27
Lubrication	Grease lubrication 28	
	Structure of suitable greases 28	
	Initial greasing and operating life..... 28	
	Relubrication of linear ball bearings in housings..... 29	
	Lubrication nipples for housings 29	
	Application in special environments..... 31	
	Oil lubrication 31	
Suitable oils 31		
Design of bearing arrangements	Location 32	
	Linear ball bearings KH 32	
	Linear ball bearings KN-B, KB, KS and plain bearings PAB..... 32	
	Linear ball bearings KNO-B, KBO and plain bearings PABO 33	
	Linear ball bearing and housing units 34	
	Sealing..... 35	
Gap seals or contact seals 35		

Technical principles

	Page
Operating clearance	
Tolerance and operating clearance	36
Mounting tolerances and operating clearance	37
Fitting	
Fitting of bearings.....	38
Linear ball bearings KH	38
Linear ball bearings KN-B, KNO-B, KB, KBS, KBO, KS, KSO and linear plain bearings PAB, PABO.....	39
Alignment of bearings and shafts	40
Bearings arranged in series.....	40
Bearings arranged in parallel	40
Very long guidance systems with supported shaft.....	40
Guidance systems with clearance-free or preloaded bearings.....	41
Parallel shaft and support rail units.....	41
Setting the operating clearance	41
Setting bearings clearance-free.....	41
Setting the preload	41
Suspended arrangement of guidance system	41



Load carrying capacity and life

The size of a linear ball bearing is determined by the demands made in terms of load carrying capacity, rating life and operational security.

The load carrying capacity is described in terms of:

- the basic dynamic load rating C
- the basic static load rating C₀.

The calculation of the basic dynamic and static load ratings given in the dimension tables is based on DIN 636-1.

Basic rating life

The basic rating life L is reached or exceeded by 90 % of a sufficiently large group of apparently identical bearings before the first evidence of material fatigue occurs.

$$L = \left(\frac{C}{P}\right)^3$$

$$L_h = \frac{833}{H \cdot n_{osc}} \cdot \left(\frac{C}{P}\right)^3$$

$$L_h = \frac{1666}{\bar{v}} \cdot \left(\frac{C}{P}\right)^3$$

L	m
Basic rating life L in 100 000 m	
L _h	h
Basic rating life in operating hours	
C	N
Basic dynamic load rating	
P	N
Equivalent dynamic load	
H	m
Single stroke length	
n _{osc}	min ⁻¹
Number of return strokes per minute	
\bar{v}	m/min
Mean travel velocity.	

Load carrying capacity and life

Operating life

The operating life is defined as the life actually achieved by a shaft guidance system. It may differ significantly from the calculated life.

The following influences can lead to premature failure through wear or fatigue:

- misalignment between the guideways and guidance elements
- contamination
- inadequate lubrication
- reciprocating motion with very small stroke lengths (false brinelling)
- vibration during stoppage (false brinelling).

Due to the variety of installation and operating conditions, the operating life of a shaft guidance system cannot be precisely determined in advance. The safest way to arrive at an appropriate estimate of the operating life is comparison with similar applications.

Static load safety factor

The static load safety factor S_0 indicates the security against impermissible permanent deformations in the bearing and is determined in accordance with the formula below.

Attention!

For linear ball bearings KH and KN.-B, the value must be $S_0 \geq 4$.

In relation to guidance accuracy and smooth running, a value of $S_0 \geq 2$ is regarded as permissible. If $S_0 < 2$, please contact us.

$$S_0 = \frac{C_0}{P_0}$$

S_0 Static load safety factor –
 P_0 Equivalent static load N
 C_0 Basic static load rating. N



Influence of the shaft raceway on the basic load ratings

The basic load ratings in the dimension tables are only valid if a ground ($R_a 0,3$) and hardened shaft (at least 670 HV) is provided as a raceway.

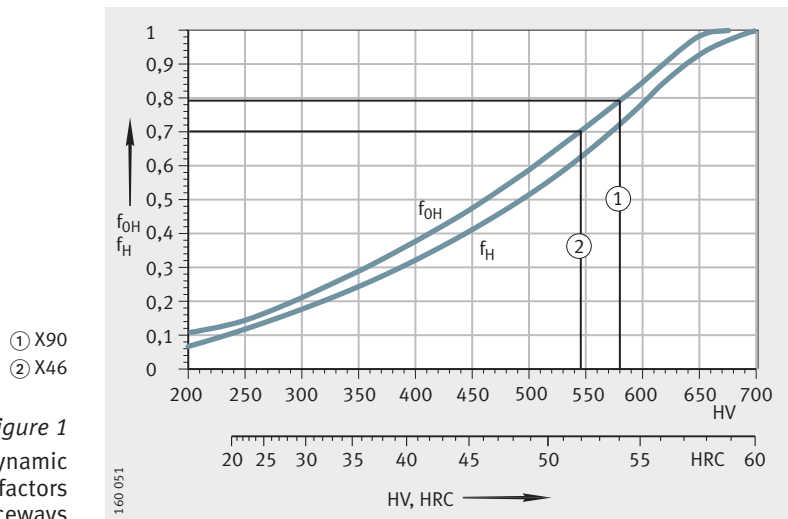
Differences in raceway hardness

If shafts with a surface hardness lower than 670 HV are used (for example, shafts made from X46 or X90), a hardness factor must be applied, see formulae and *Figure 1*.

$$C_H = f_H \cdot C$$

$$C_{OH} = f_{OH} \cdot C_0$$

C	N
Basic dynamic load rating	
C_0	N
Basic static load rating	
C_H	N
Effective dynamic load rating	
C_{OH}	N
Effective static load rating	
f_H	-
Dynamic hardness factor, <i>Figure 1</i>	
f_{OH}	-
Static hardness factor, <i>Figure 1</i>	



Load carrying capacity and life

Load direction and position of the ball rows

The effective load rating of a linear ball bearing is dependent on the position of the load direction in relation to the position of the ball rows:

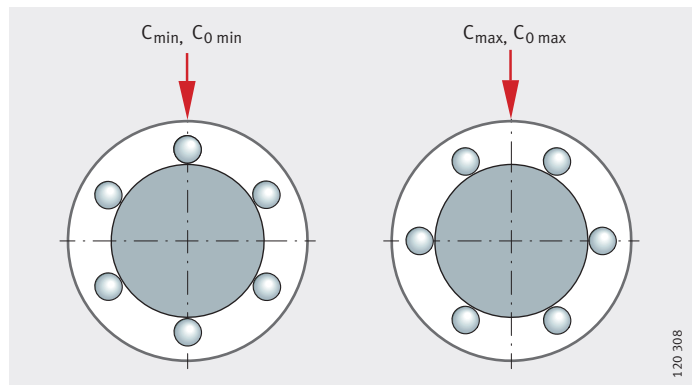
- the lowest load rating C_{\min} and $C_{0 \min}$ occur in the zenith position, *Figure 2*
- the highest load rating C_{\max} and $C_{0 \max}$ occur in the symmetrical position, *Figure 2*.

If the bearings are fitted in correct alignment, the maximum load rating can be used. If aligned fitting is not possible or the direction of loading is not defined, the minimum load ratings must be assumed.

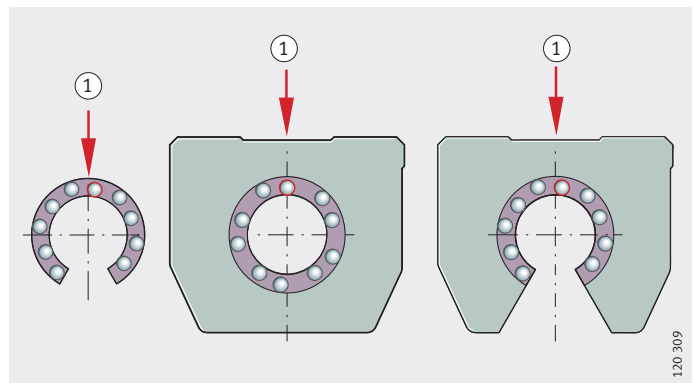
Main load direction

For linear ball bearings and linear ball bearing and housing units where the fitting position of the ball rows is defined, the basic load ratings C and C_0 in the main load direction are given, *Figure 3*. For other load directions, the effective load ratings can be determined using the load direction factors in *Figure 4* to *Figure 21*. If the fitting position of the ball rows is not defined, the minimum load ratings are given.

Figure 2
Load carrying capacity, dependent on the position of the ball rows



① Main load direction
Figure 3
Main load direction for bearings and bearing and housing units





Linear ball bearings The basic load ratings given in the dimension tables are defined as follows:

- For KH, KN-B, KS, KB and KBS, the minimum and maximum load ratings apply in accordance with *Figure 2*.
- For KNO-B, KSO and KBO, the basic load ratings apply in the main load direction.
For other load directions see *Figure 4* to *Figure 13*.

Linear ball bearing and housing units The basic load ratings given in the dimension tables are defined as follows:

Compact range For the units KGHK, KTHK, KGHW, KGHWT, the minimum load rating applies.

Light range For the units KGN, KTN, KTFN, KGNS, KTNS and the open units KGNO, KTNO, KGNC, KGNOS, KTNOS, KGNCS, the basic load rating applies in the main load direction.
For other load directions see *Figure 10* to *Figure 13*.

Heavy duty range For the heavy duty range, the basic load rating applies in the main load direction.
For other load directions see *Figure 14* to *Figure 17*.

Machined range For the units KGB, KGBA, KTB, KGBS, KGBAS, the minimum load rating applies.
For the open units KGBO, KGBAO, the basic load rating applies in the main load direction.
For other load directions see *Figure 20* to *Figure 21*.

Load direction factors The factors in *Figure 4* to *Figure 13* are applied as follows:

$$C_w = f_S \cdot C$$

C	N
Basic dynamic load rating	
C_w	N
Effective dynamic load rating	
f_S	–
Dynamic load factor for load direction.	

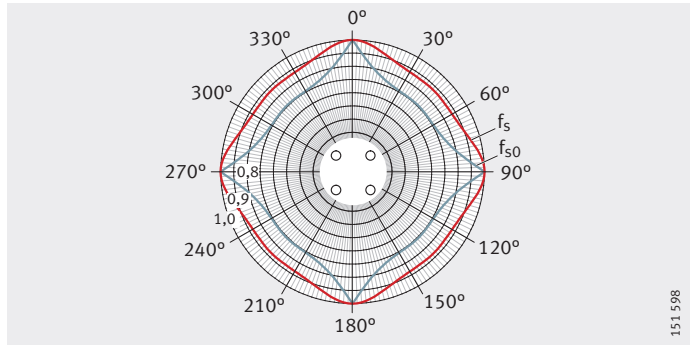
$$C_{0w} = f_{S0} \cdot C_0$$

C_0	N
Basic static load rating	
C_{0w}	N
Effective static load rating	
f_{S0}	–
Static load factor for load direction.	

Load carrying capacity and life

Figure 4

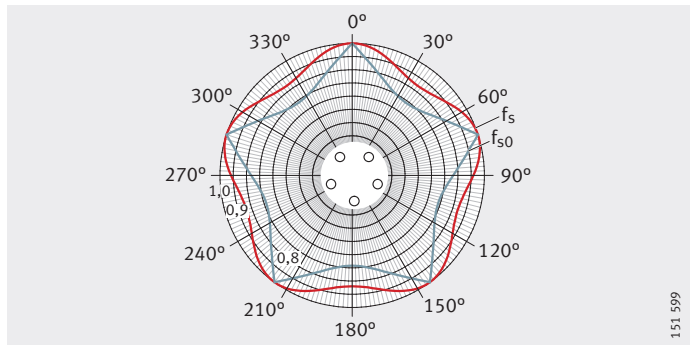
Compact range
Load direction factor for
KH06, KH08, KH10



151 598

Figure 5

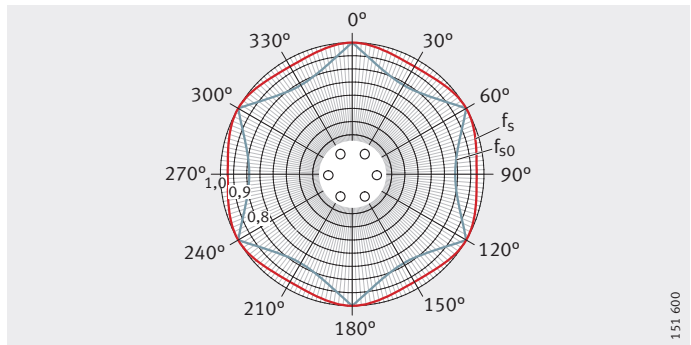
Compact range
Load direction factor for
KH12, KH14, KH16



151 599

Figure 6

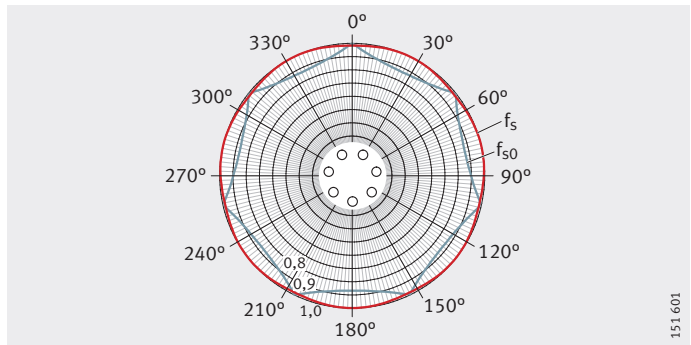
Compact range
Load direction factor for
KH20, KH25



151 600

Figure 7

Compact range
Load direction factor for
KH30



151 601



Figure 8
Compact range
Load direction factor for
KH40

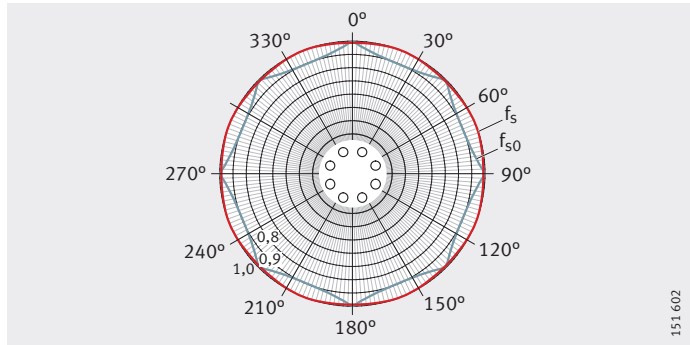
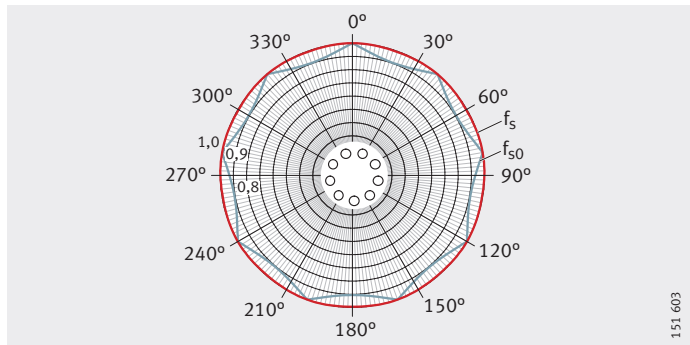
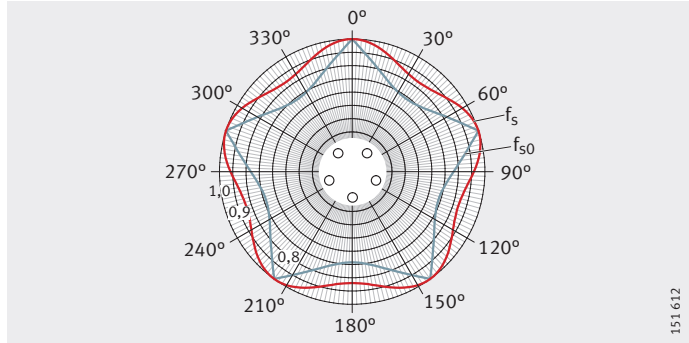


Figure 9
Compact range
Load direction factor for
KH50



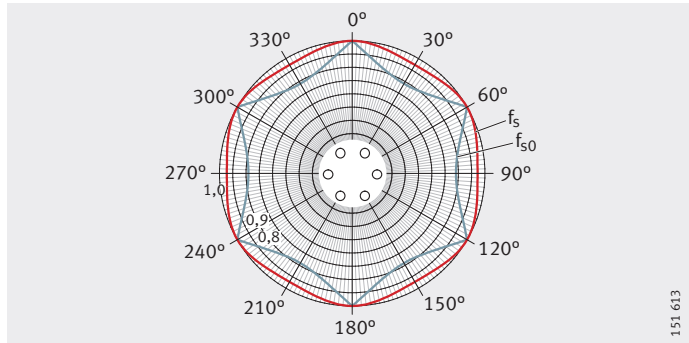
Load carrying capacity and life

Figure 10
Light range
 Load direction factor for
 KN12-B, KN16-B



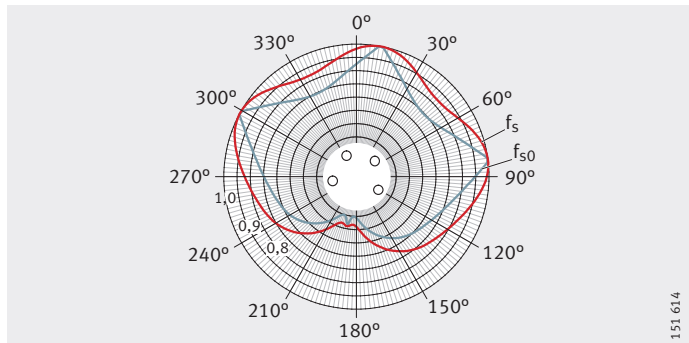
151 612

Figure 11
Light range
 Load direction factor for
 KN20-B, KN25-B, KN30-B,
 KN40-B, KN50-B



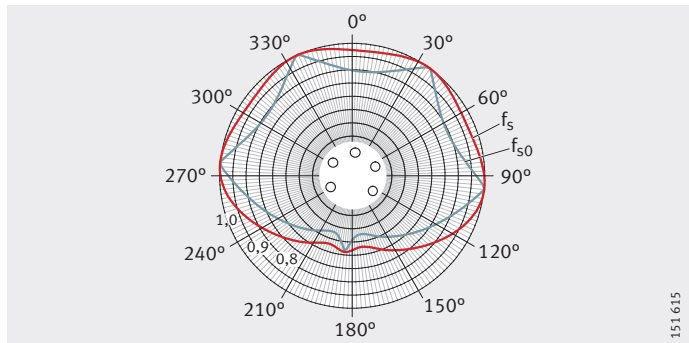
151 613

Figure 12
Light range
 Load direction factor for
 KNO12-B, KNO16-B



151 614

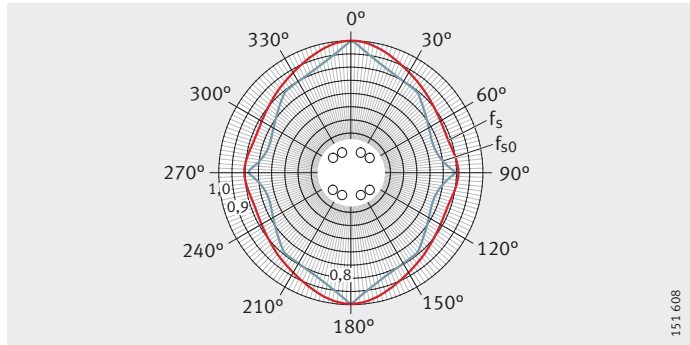
Figure 13
Light range
 Load direction factor for
 KNO20-B, KNO25-B, KNO30-B,
 KNO40-B, KNO50-B



151 615

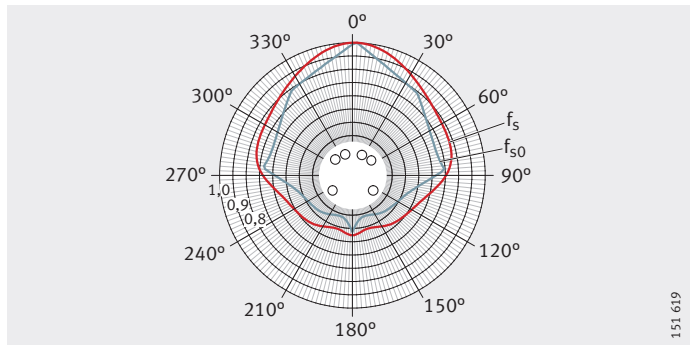


Figure 14
Heavy duty range
Load direction factor for
KS12, KS16, KS20, KS25, KS30,
KS40, KS50



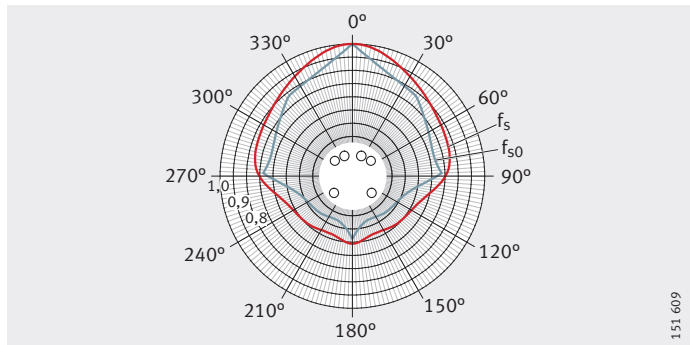
151.608

Figure 15
Heavy duty range
Load direction factor for
KS012, KS016



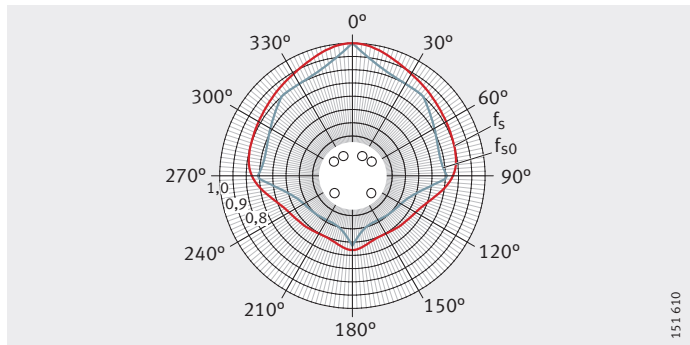
151.619

Figure 16
Heavy duty range
Load direction factor for
KS020, KS025



151.609

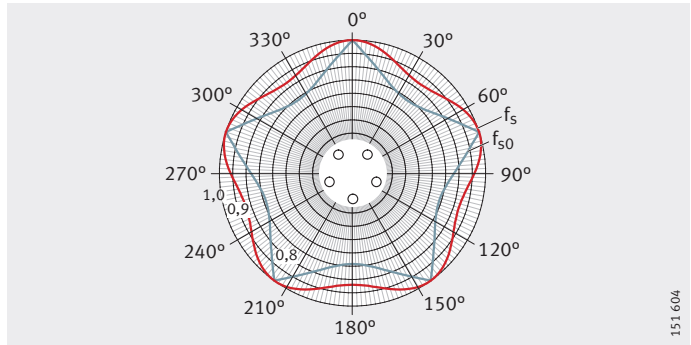
Figure 17
Heavy duty range
Load direction factor for
KS030, KS040, KS050



151.610

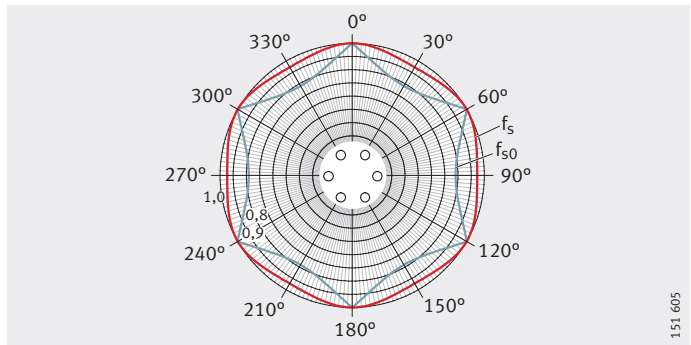
Load carrying capacity and life

Figure 18
Machined range
 Load direction factor for
 KB12, KB16



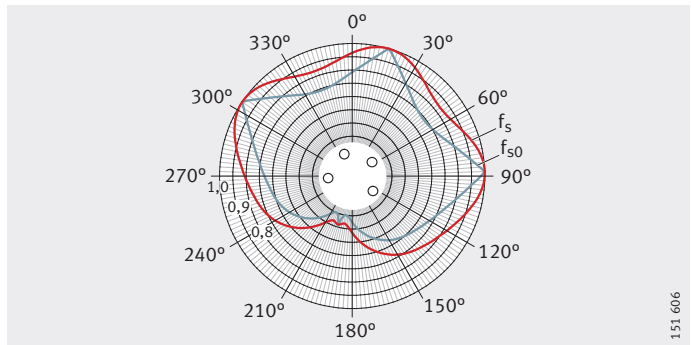
151 604

Figure 19
Machined range
 Load direction factor for
 KB20, KB25, KB30, KB40, KB50



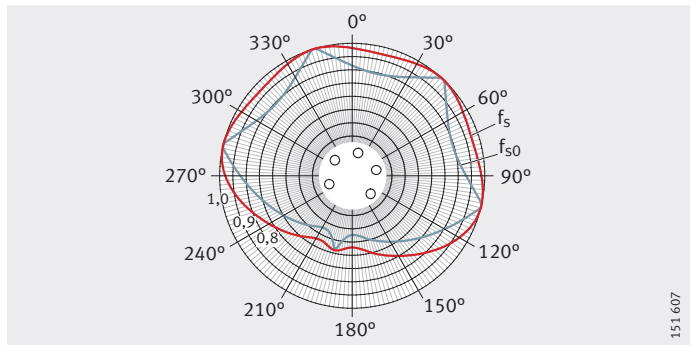
151 605

Figure 20
Machined range
 Load direction factor for
 KBO12, KBO16



151 606

Figure 21
Machined range
 Load direction factor for
 KBO20, KBO25, KBO30,
 KBO40, KBO50



151 607



Misalignment of the shaft

Misalignment of the shaft impairs the running quality and operating life of linear ball bearings. Guidance systems with one shaft should therefore have at least two bearings, while guidance systems with two shafts should have at least three bearings.

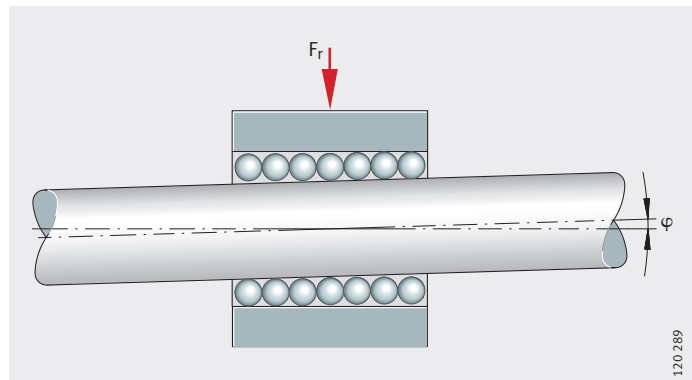
Load factors in misalignment

Due to shaft flexing, it is not always possible to avoid misalignment, *Figure 22*. If it is present, load factors for misalignment should be applied, *Figure 23* and *Figure 24*, page 26.

$$P = K_F \cdot F_r$$

$$P_0 = K_{F0} \cdot F_r$$

- F_r N
Maximum radial bearing load
- C, C_0 N
Basic dynamic or static load rating
- P, P_0 N
Equivalent dynamic or static load
- K_F, K_{F0} –
Dynamic or static load factor for misalignment, *Figure 23* or *Figure 24*, page 26
- φ angular minutes
Misalignment angle, *Figure 22*.



F_r = radial load

Figure 22

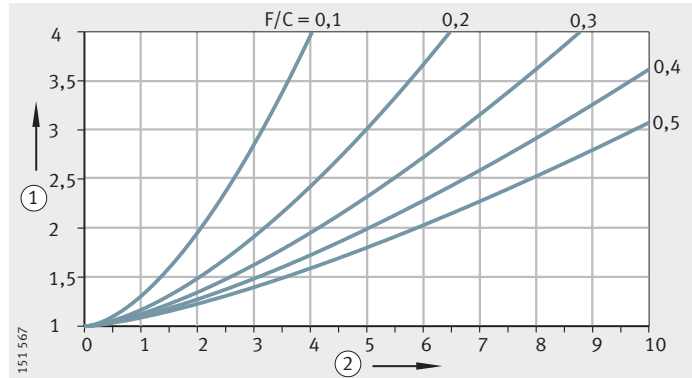
Misalignment φ of the shaft

120_289

Load carrying capacity and life

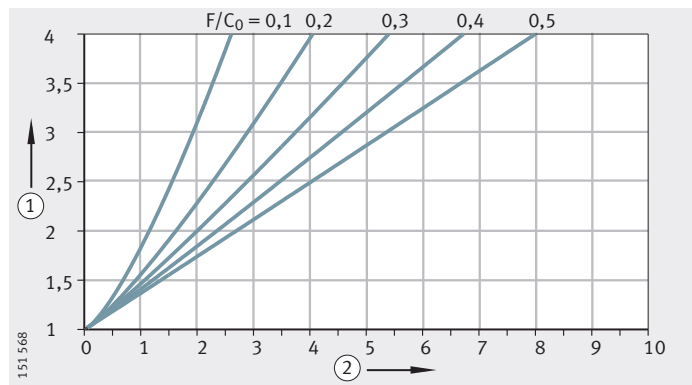
- ① Dynamic load factor K_F
- ② Misalignment φ in angular minutes

Figure 23
Dynamic load factor
for shaft misalignment



- ① Static load factor K_{F0}
- ② Misalignment φ in angular minutes

Figure 24
Static load factor
for shaft misalignment



Compensation of misalignments in the light and heavy duty range

Linear ball bearings KN-B, KNO-B, KS and KSO and linear ball bearing and housing units containing these bearings are self-aligning. They can compensate misalignments of up to ± 30 angular minutes (KN-B and KNO-B) or ± 40 angular minutes (KS and KSO) without any detrimental effect on the load carrying capacity.



Friction

Linear ball bearings are frequently used where high positional accuracy and high efficiency are a priority. The bearings must therefore run without stick-slip and with only low friction.

Linear ball bearings KN-B, KNO-B,KS, KSO, KB, KBS, KBO have particularly low friction.

Coefficient of friction

The total friction consists of:

- rolling and sliding friction in rolling contacts (sliding friction in linear plain bearings)
- friction in the return zones and recirculation guides
- lubricant friction
- seal friction.

The factors on which the coefficient of friction depends may act in a reciprocal manner, may act in a single direction or may counteract each other.

Coefficient of friction in unsealed bearings

The coefficients of friction for unsealed linear bearings with oil lubrication are given in the table.

In Permaglide[®] linear plain bearings, the coefficient of friction is between 0,02 and 0,2.

Series and coefficient of friction

Series	Coefficient of friction
KH	0,003 – 0,005
KN-B, KNO-B	0,001 – 0,0025
KS, KSO	0,001 – 0,0025
KB, KBS, KBO	0,001 – 0,0025

Lubrication

Open linear ball bearings are supplied with a wet or dry preservative and can be lubricated using either grease or oil. The oil-based preservative is compatible and miscible with lubricants having a mineral oil base, which means that it is not generally necessary to wash out the bearings before fitting.

Bearings with a dry preservative must be greased or oiled immediately after they are removed from the packaging.

Grease lubrication

Grease lubrication should be used in preference to oil lubrication, since the grease adheres to the inside of the bearing and thus prevents the ingress of contamination. This sealing effect protects the rolling elements against corrosion.

In addition, the design work involved in providing grease lubrication is less than that for providing oil, since design of the sealing arrangement is less demanding.

Structure of suitable greases

The greases for linear ball bearings have the following composition:

- lithium or lithium complex soaps
- base oil: mineral oil or poly-alpha-olefin (PAO)
- special anti-wear additives for loads $C/P < 8$, indicated by "P" in the DIN designation KP2K-30
- consistency to NLGI class 2 in accordance with DIN 51818.

Initial greasing and operating life

Based on experience, the operating life is achieved when bearings are operated with grease lubrication in normal environmental conditions ($C/P > 10$), at room temperature and at $v \leq 0,6 \cdot v_{\max}$. If it is not possible to achieve these conditions, the bearings must be relubricated.

Sealed linear ball bearings are already adequately greased when delivered and are therefore maintenance-free in many applications.

Initial greasing and relubrication of bearings

The initial greasing and relubrication of linear ball bearings without seals and relubrication holes must be carried out via the shaft. It must be ensured that all rolling elements come into contact with grease during recirculation. The bearing must be moved over at least twice its length during relubrication.

During initial greasing, the bearing fitted on the shaft should be fed with lubricant until this begins to emerge from the bearing.

In linear ball bearings KH, KN..-B-PP-AS, KS..-PP-AS and PAB..-PP-AS, relubrication can be carried out via holes or openings in the retaining ring or outer ring.

Relubrication interval

The relubrication interval is dependent on many operating conditions such as load, temperature, speed, stroke length, lubricant, environmental conditions and the mounting position.

Attention!

The precise lubrication intervals should be determined by tests conducted under application conditions.

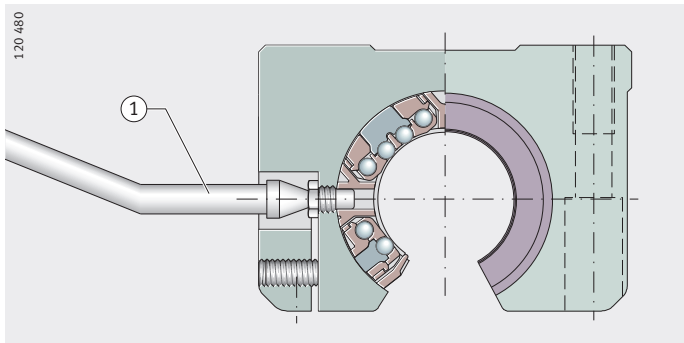


Relubrication of linear ball bearings in housings

If linear ball bearings are mounted in a housing, special nozzle tubes may be required for relubrication, *Figure 1* and *Figure 2*. Sources for nozzle tubes with suitable needle point heads can be requested from us.



Figure 1
Nozzle tube

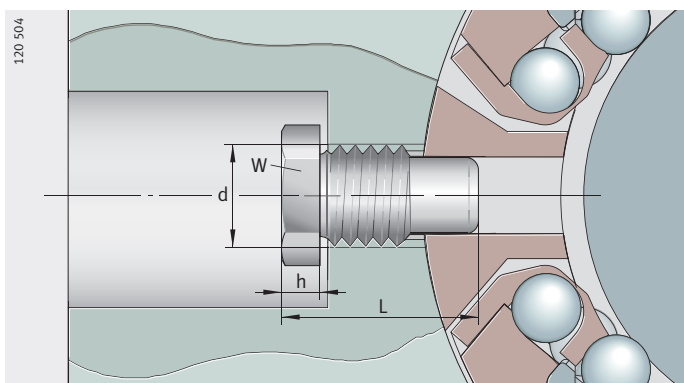


① Nozzle tube

Figure 2
Relubrication using nozzle tube

Lubrication nipples for housings

Lubrication nipples for housings with KS are shown in *Figure 3*, suitable DIN lubrication nipples for housings with KN-B are shown in *Figure 4* and *Figure 5*, page 30, for other housings, *Figure 6*, page 31. The dimensions are given in the tables.



NIP..MZ

Figure 3
Lubrication nipple for heavy duty range KS

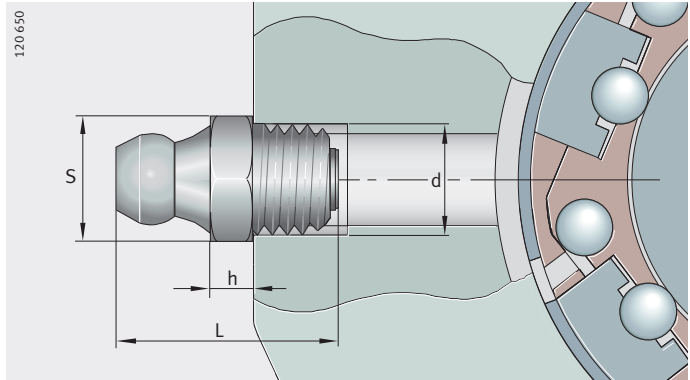
Lubrication nipple

Lubrication nipple	Dimensions in mm			
	Width across flats W	d	L	h
NIP4MZ	5	M4	7,7	1,5
NIP5MZ	6	M5	11,1	2
NIP6MZ	7	M6	14,8	2,5

Lubrication

NIP DIN 71412

Figure 4
Lubrication nipple
DIN 71412 type A
for light range KN-B

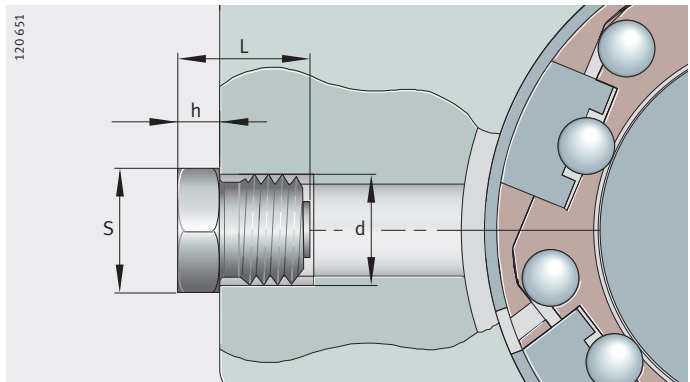


Taper type lubrication nipples

Taper type lubrication nipple	Dimensions in mm			
	S h13	d	L	h j16
NIP DIN 71412-AM6	7	M6	16	3
NIP DIN 71412-AM8X1	9	M8×1	16	3

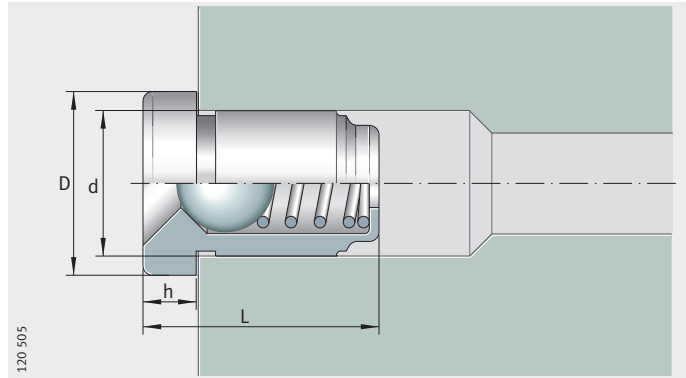
NIP DIN 3405

Figure 5
Alternative lubrication nipple
DIN 3405 type A
for light range KN-B



Funnel type lubrication nipples

Funnel type lubrication nipple	Dimensions in mm			
	S h13	d	L	h j16
NIP DIN 3405-AM6	7	M6	9,5	3
NIP DIN 3405-AM8X1	9	M8×1	9,5	3



NIPA

Figure 6

Lubrication nipple for compact range KH, machined range KB, plain bearing range PAB

Lubrication nipples

Lubrication nipple	Dimensions in mm			
	D	d	L	h
NIPA1	6	4	6	1,5
NIPA2	8	6	9	2

Application in special environments

In vacuum applications, lubricants with low vapourisation rates are required in order to maintain the vacuum atmosphere.

In the foodstuffs sector and clean rooms, special requirements are also placed on lubricants in relation to emissions and compatibility. For such environmental conditions, please consult us.

Oil lubrication

Oil lubrication should be used in preference if heat is to be dissipated and contaminants are to be carried out of the bearing by the lubricant.

This advantage should be set against the increased design work required (lubricant feed, sealing).

Suitable oils

As a function of the load case, we recommend the following oils:

- At low to moderate loads ($C/P > 15$):
 - Hydraulic oils HL to DIN 51 524 and oils CL to DIN 51 517 in the viscosity range ISO-VG 10 to ISO-VG 22.
- At high loads ($C/P < 8$):
 - Hydraulic oils HLP to DIN 51 524 and oils CLP to DIN 51 517 in the viscosity range ISO-VG 68 to ISO-VG 100.

Design of bearing arrangements

The good running characteristics of shaft guidance systems are dependent not only on the bearings. The geometrical and positional tolerances of the adjacent construction also play a significant role. The higher the accuracy to which the adjacent construction is produced and assembled, the better the running characteristics.

Location

Linear ball bearings KH

Linear ball bearings KH and KH..-PP are pressed into the housing bore. This provides axial and radial location. No additional means of location are required.

Linear ball bearings KN-B, KB, KS and plain bearings PAB

Linear ball bearings KN-B, KB, KS and plain bearings PAB must be axially located, for example by means of retaining rings or by the adjacent construction, *Figure 1 to Figure 3*.

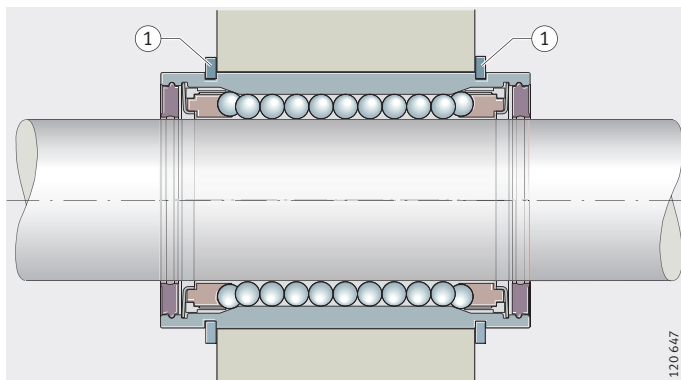
Linear ball bearings KN-B can also be located by means of a screw, *Figure 4*.

Attention!

Series KN-B and KS must not be located by means of shaft retaining rings. This could impair the function of the bearing.

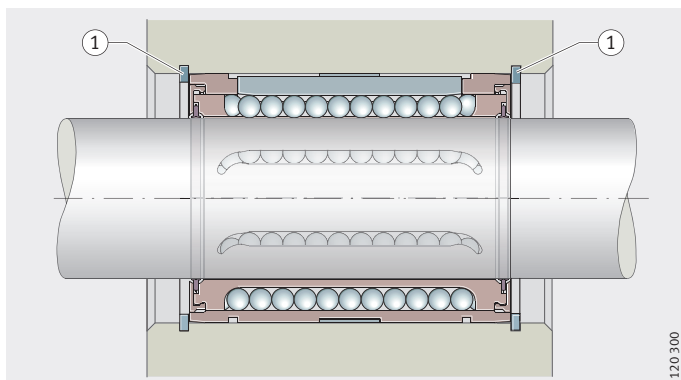
① Retaining rings

Figure 1
Retaining rings
in the bearing slots



① Retaining rings

Figure 2
Retaining rings
in the housing bore





Linear ball bearings KNO-B, KBO and plain bearings PABO

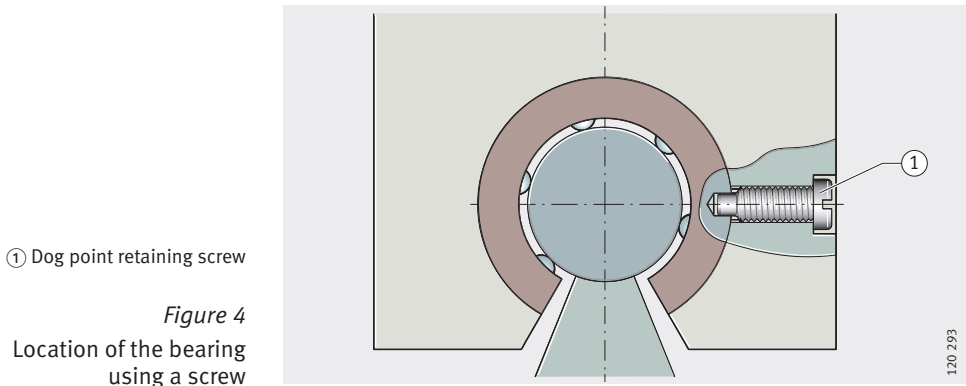
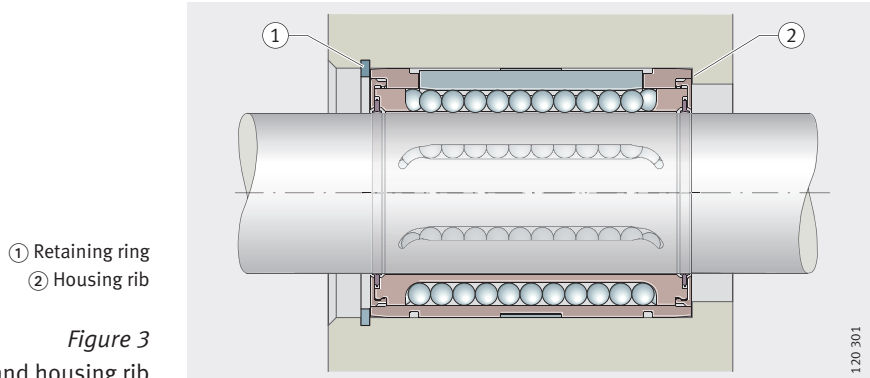
Linear ball bearings KNO-B, KBO and plain bearings PABO must be axially and radially located.

These bearings are located by external means. A dog point screw should preferably be used for location, *Figure 4*.

Set screws are also suitable.

Attention!

The locating screw must not be allowed to deform the bearing. The screw must be secured against loosening.



Design of bearing arrangements

Linear ball bearing and housing units

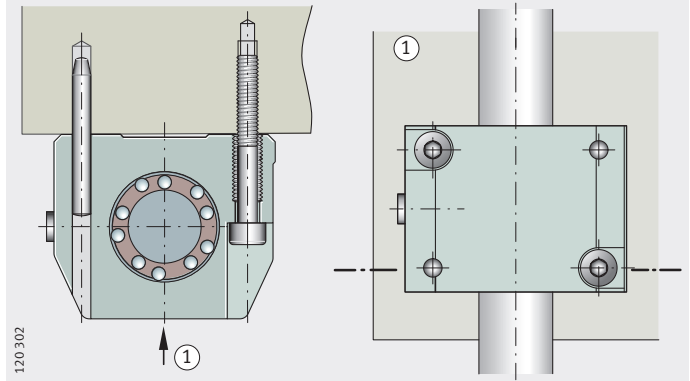
Linear ball bearing and housing units and linear plain bearing units are screw mounted into or through the fixing holes, *Figure 5* and *Figure 6*.

Location of the units by means of dowels is only necessary in rare cases, but can be achieved easily by drilling out the centring holes.

① Bottom view

Figure 5

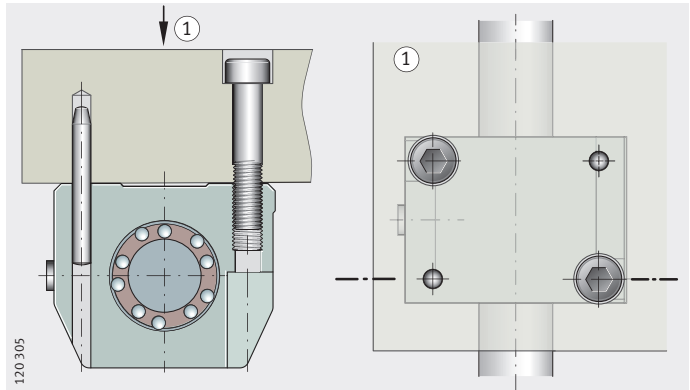
Location of a unit from below



① Top view

Figure 6

Location of a unit from above





Sealing Clean raceways are necessary in order to prevent premature failure of the shaft and bearing. The bearing position should therefore always be sealed.

Gap seals or contact seals The seals for the bearing series are shown in table Seals for bearings and units.

Gap seals protect the bearings against coarse contaminants. Contact seals give protection against fine contaminants and also retain the grease in the bearing.

Linear ball bearings and linear plain bearings with contact seals have the suffix PP, example KH..-PP.

Attention! If the bearing and shaft are in a highly aggressive environment, it is recommended that the guidance system should be provided with additional protection by means of bellows or telescopic covers.

Seals for bearings and units

Series ¹⁾	Seal		
	Open design	Gap seal	Contact seal ¹⁾
KH	●	–	●
KN-B, KNO-B	–	●	●
KS, KSO	–	●	●
KB, KBO	–	●	●
PAB, PABO	–	–	●

● Available design.

¹⁾ All linear bearing units have contact seals.

Operating clearance

Tolerance and operating clearance

The operating clearance of linear bearings is defined by the selection of shaft and housing tolerance, see tables, page 37.

The operating clearance of linear bearing units is defined either by the shaft or, in the case of slotted housings, is set by means of the adjustment screw.

Attention!

With non-rigid housings, tests must be carried out in order to achieve the required operating clearance by means of the housing and shaft tolerances.

For adjustment of the operating clearance see page 41.

Tolerance and operating clearance

Linear bearings and linear bearing and housing units	Designation	Tolerance		Operating clearance
		Shaft	Bore	
Compact range	KH	See table, page 37		
	KGHK, KTHK	h6	–	Standard
Adjusting range	KGHW, KGHWT	h6	–	Standard
Light range	KN-B, KNO-B	h6	H7	Slight preload
	KGN, KTN, KTFN, KGNO, KTNO, KGNC	h6	–	Slight preload
	KGNS, KTNS, KGNOS, KTNOS, KGNSCS	–	–	Adjustable by means of screw
Heavy duty range	KS, KSO	h6	H7	Slight preload
	KGSNG, KTSG, KGSNO, KTSO, KGSC, KTFS	h6	–	Slight preload
	KGSNS, KTSS, KGSNOS, KTSOS, KGSCS	–	–	Adjustable by means of screw
Machined range	KB	See table, page 37		
	KBS, KBO			
	KGB, KGBA, KTB, KGBO, KTBO	h6	–	See table, page 37
	KGBS, KGBAS, KGBAO	–	–	Adjustable by means of screw
Plain bearing range	PAB, PABO	h7	H7	Standard
	PAGBA, PAGBAO	h7	–	Standard



Mounting tolerances and operating clearance

The theoretically possible operating clearance for the individual series is shown in the following tables and *Figure 1*.

Operating clearance for KH, KN-B, KNO-B

Mounting tolerance		Operating clearance	
		All sizes	
Shaft	Bore		
h6	H7, K7	Normal operating clearance	Steel/aluminium
j5	H6, K6	Operating clearance smaller than normal	Steel/aluminium

Operating clearance for KS, KSO

Mounting tolerance		Size and operating clearance (clearance in μm)						
Shaft	Bore	12	16	20	25	30	40	50
h6	H6	+36 -8	+34 -10	+37 -12	+34 -15	+29 -20	+33 -22	+30 -25
h6	H7	+44 -8	+32 -10	+46 -12	+43 -15	+38 -20	+44 -22	+41 -25
h6	JS6	+29 -14,5	+27,5 -16,5	+29 -20	+26 -23	+21 -28	+23,5 -31,5	+20,5 -34,5

Operating clearance for KB

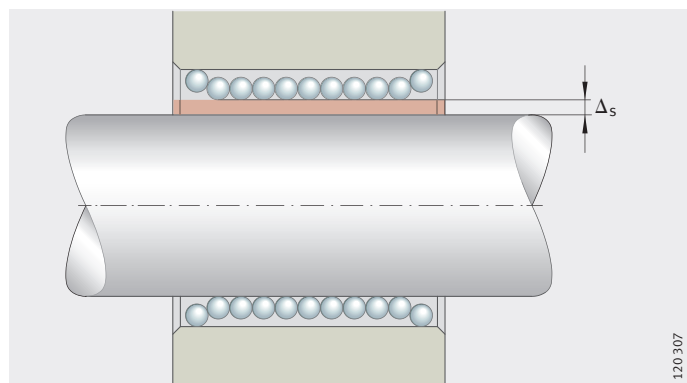
Mounting tolerance		Size and operating clearance (clearance in μm)						
Shaft	Bore	12	16	20	25	30	40	50
h6	H6 (H7)	+19 0	+20 -1	+22 -1	+24 -1	+24 -1	+29 -2	+29 -2

Operating clearance for KBS, KBO

Mounting tolerance		Size and operating clearance (clearance in μm)						
Shaft	Bore	12	16	20	25	30	40	50
h6	H6	+50 0	+51 -1	+60 -1	+62 -1	+62 -1	+74 -2	+74 -2
h6	H7	+58 0	+59 -1	+69 -1	+71 -1	+71 -1	+85 -2	+85 -2
h6	JS6	+43,5 -6,5	+44,5 -7,5	+52 -9	+54 -9	+54 -9	+64,5 -11,5	+64,5 -11,5

Δ_s = operating clearance

Figure 1
Operating clearance



120 307

Fitting

Bearings should only be removed from their packaging immediately before assembly. Bearings with dry preservative should be protected against corrosion immediately after removal from the packaging.

Attention!

The assembly area and the adjacent construction must be clean. Contamination impairs the accuracy and operating life of the guidance systems.

The bearings must not be tilted.

In the case of sealed bearings with a segment cutout, it must be ensured at all costs that the ends of the seal lips are not turned inside out (pay attention to the packing slip).

Fitting of bearings

Linear ball bearings KH

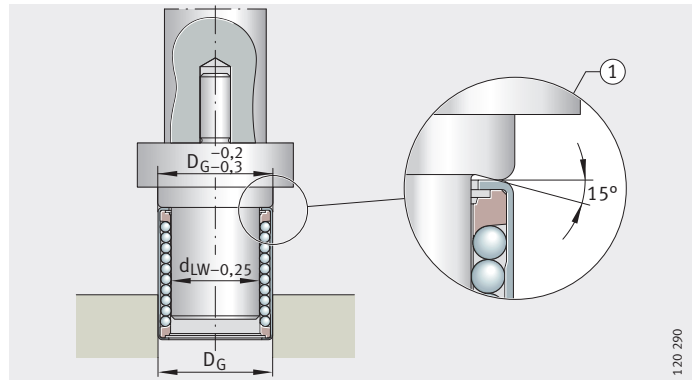
Linear ball bearings KH are pressed into the housing bore using a fitting mandrel, *Figure 1*. The mandrel dimensions must be in accordance with *Figure 1*.

The marked end face of the linear ball bearing should be in contact with the flange of the mandrel.

Linear ball bearings can be fitted more easily if the outside surface is greased.

d_{LW} = shaft diameter
 D_G = housing bore
① Detail

Figure 1
Pressing-in
of linear ball bearing KH





Linear ball bearings KN-B, KNO-B, KB, KBS, KBO, KS, KSO and linear plain bearings PAB, PABO

Attention!

Smaller bearings of these series can be slid into the housing bore by hand. For larger bearings, it is advisable to use a fitting mandrel, *Figure 2*.

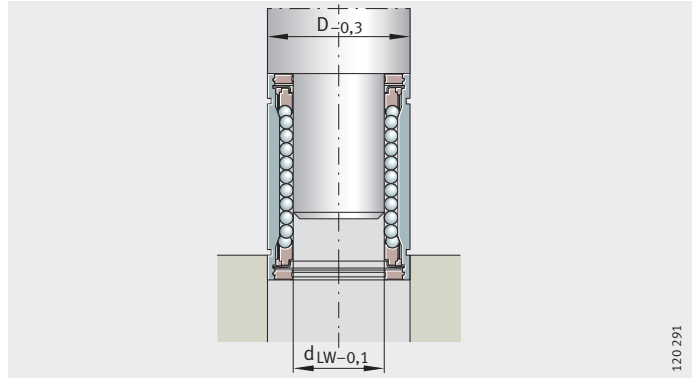
The bearings are then located by means of retaining rings or a screw, *Figure 3*.

In the case of all bearings located by means of a screw, it must be ensured that the screw does not deform the bearing and the screw is secured against loosening.

d_{LW} = shaft diameter

Figure 2

Fitting of linear ball bearing using fitting mandrel

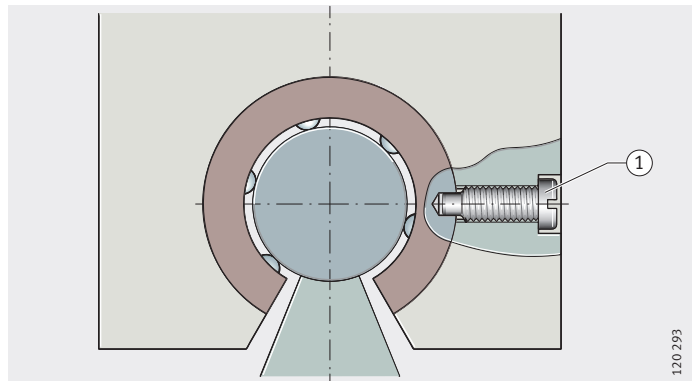


120 291

① Dog point retaining screw

Figure 3

Location of the bearing using a screw



120 293

Fitting

Alignment of bearings and shafts

Bearings arranged in series

Bearings arranged in series should be aligned with a continuous shaft, positioned against a stop and then screw mounted firmly in place.

Bearings arranged in parallel

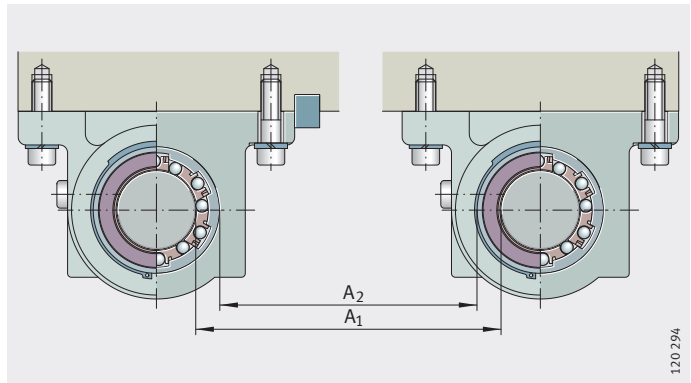
Bearings arranged in parallel are aligned by measuring the spacing between the shafts (A_1) or between the bearing outside diameters (A_2), *Figure 4*. This spacing can also be defined by means of spacers.

The first shaft is set (datum shaft) and screw mounted. The second shaft is aligned by moving the table to achieve the required spacing.

A_1 = spacing between the shafts
 A_2 = spacing between the bearing outside diameters

Figure 4

Alignment of bearings arranged in parallel



Very long guidance systems with supported shaft

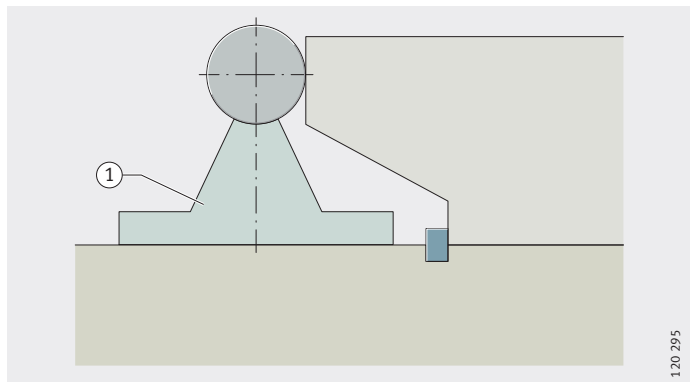
In very long guidance systems with supported shafts, one shaft and support rail unit is first aligned by means of the shaft and screw mounted firmly in place in stages (datum shaft), *Figure 5*.

The procedure described in Bearings arranged in parallel is then carried out.

① Shaft and support rail unit

Figure 5

Alignment of a shaft and support rail unit by means of the shaft





Guidance systems with clearance-free or preloaded bearings

Only one row of bearings arranged in series should be set clearance-free or preloaded. The bearings parallel thereto should have a substantial operating clearance.

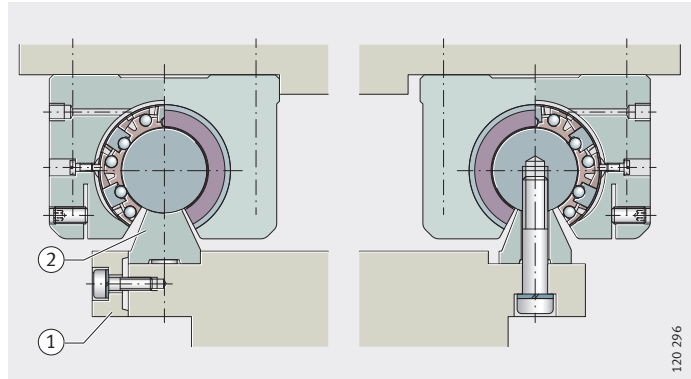
Parallel shaft and support rail units

Clamp the datum support rail against a stop, *Figure 6*.

- ① Stop
- ② Datum support rail

Figure 6

Clamping of the datum support rail when using two shaft and support rail units TSUW



120 296

Setting the operating clearance Setting bearings clearance-free

In the case of linear ball bearings KBS and slotted housings, the operating clearance can be adjusted. The screw must be adjusted until resistance to further rotation can be felt between the shaft and bearing.

Attention!

The adjusted bearing should not be rotated any further on the shaft.

Setting the preload

Preloaded bearings are set clearance-free on a master shaft that is smaller than the actual shaft in the application by the amount of the preload dimension.

Suspended arrangement of guidance system

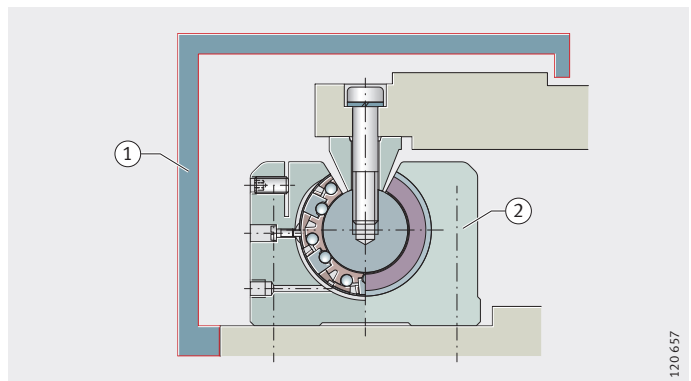
Attention!

If the guidance system is in a suspended arrangement, a drop guard ① is recommended, *Figure 7*.

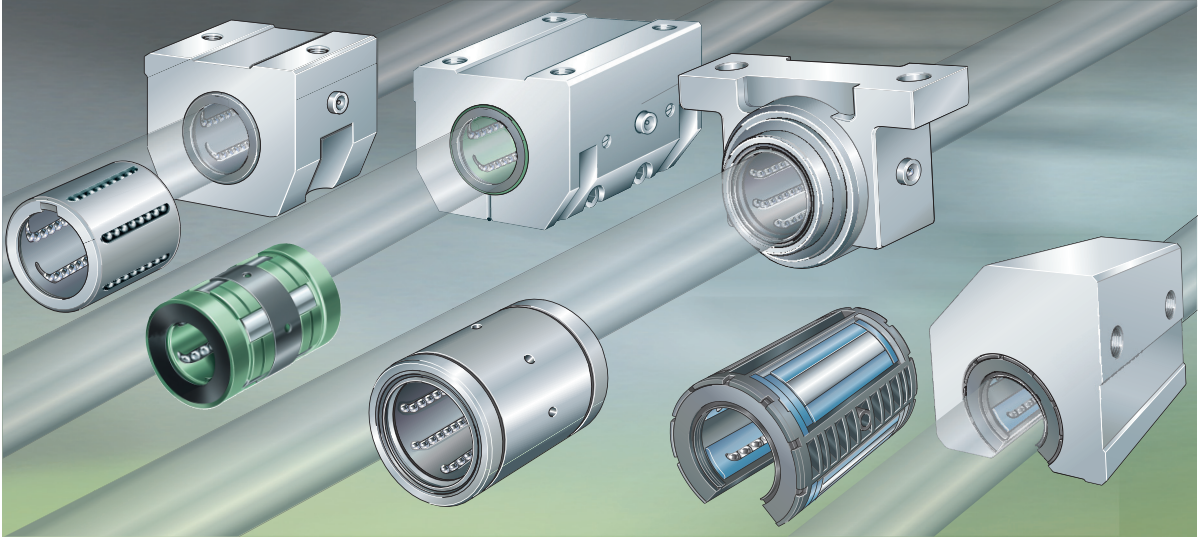
- ① Drop guard
- ② Mounting position 180°

Figure 7

Suspended shaft guidance system with drop guard



120 657



Linear bearings and linear bearing and housing units

Compact range

Light range

Heavy duty range

Machined range

Permaglide[®] plain bearing range



Linear bearings and linear bearing and housing units

		Page
Matrix	Matrix for preselection of linear bearings and linear bearing and housing units.....	44
Product overview	Linear bearings and linear bearing and housing units.....	46
	Compact range	46
	Light range	47
	Heavy duty range	48
	Machined range.....	49
	Permaglide® plain bearing range.....	51
Features	Linear bearings	52
	Linear bearing and housing units	53
	Sealing.....	54
	Lubrication	54
	Operating temperature	54
	Operating limits	55
	Suffixes	55
	Compact range	56
	Light range	58
	Heavy duty range.....	60
	Machined range	62
	Permaglide® plain bearing range	64
Dimension tables	Compact range, linear ball bearings	65
	Compact range, linear ball bearing and housing units	66
	Light range, linear ball bearings	76
	Light range, linear ball bearing and housing units	78
	Heavy duty range, linear ball bearings.....	90
	Heavy duty range, linear ball bearing and housing units	92
	Machined range, linear ball bearings.....	104
	Machined range, linear ball bearing and housing units.....	106
	Permaglide® plain bearing range, linear plain bearings.....	114
	Permaglide® plain bearing range, linear plain bearing units.....	116

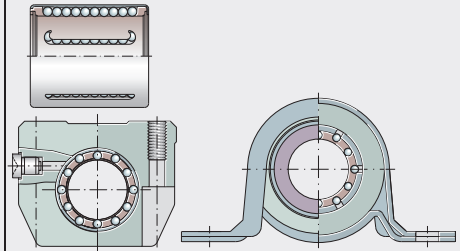


**Matrix for preselection
of linear bearings
and linear bearing
and housing units**

Linear bearings, linear bearing and housing units

Compact range

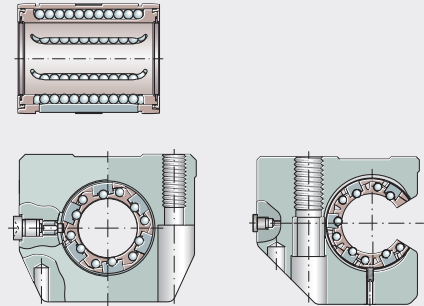
- KH
- KH..-PP
- KGHK..-PP-AS
- KTHK..-PP-AS
- KGHW..-PP
- KGHWT..-PP
- KGHA..-PP



120 496

Light range

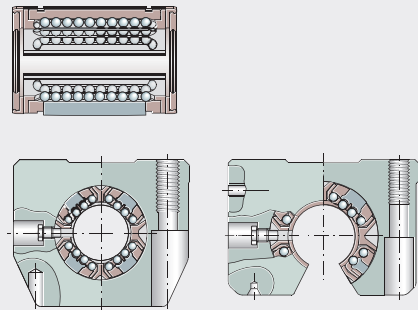
- KN..-B, KN..-B-PP
- KNO..-B, KNO..-B-PP
- KGN..-C-PP-AS
- KGNS..-C-PP-AS
- KTN..-C-PP-AS
- KTNS..-C-PP-AS
- KGNO..-C-PP-AS
- KGNOS..-C-PP-AS
- KTNO..-C-PP-AS
- KTNOS..-C-PP-AS
- KGNC..-C-PP-AS
- KGNCs..-C-PP-AS
- KTFN..-C-PP-AS



120 497

Heavy duty range

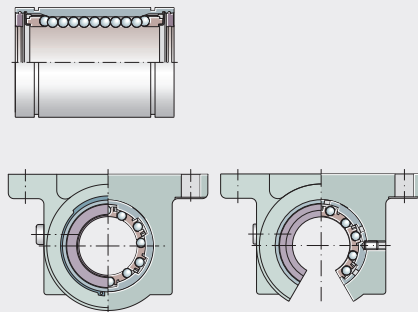
- KS, KS..-PP
- KSO, KSO..-PP
- KGSNG..-PP-AS
- KGSNS..-PP-AS
- KTSg..-PP-AS
- KTSS..-PP-AS
- KGSNO..-PP-AS
- KGSNOS..-PP-AS
- KTSO..-PP-AS
- KTSOS..-PP-AS
- KGSC..-PP-AS
- KGSCS..-PP-AS
- KTFs..-PP-AS



120 498

Machined range

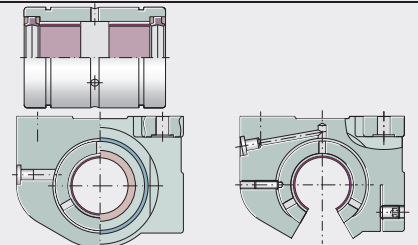
- KB, KBS, KBO
- KB..-PP, KBS..-PP
- KBO..-PP
- KB..-PP-AS
- KBS..-PP-AS
- KBO..-PP-AS
- KGB..-PP-AS
- KGBS..-PP-AS
- KGBO..-PP-AS
- KGBA..-PP-AS
- KGBAS..-PP-AS
- KGBAO..-PP-AS
- KFB..-PP-AS
- KTB..-PP-AS
- KTB0..-PP-AS



120 499

Permaglide® plain bearing range

- PAB..-PP-AS
- PABO..-PP-AS
- PAGBA..-PP-AS
- PAGBAO..-PP-AS



120 500

Definition of symbols

- +++ Very good
- ++ Good
- + Satisfactory
- Available for shaft diameter

Linear bearings KH, KN-B, KNO-B, KS, KSO with the suffix PP are sealed on both sides.

Linear bearings with the suffix PP-AS are sealed on both sides and can be relubricated.

For shaft diameter in mm											Design		Characteristics					
06	08	10	12	14	16	20	25	30	40	50	Closed	Segment cutout	Feature	Load carrying capacity	Precision	Self-aligning	Adjustable	Description: see page
●	●	●	●	●	●	●	●	●	●	●	KH	–	Low section height	+	+	–	–	53, 56
–	–	–	●	–	●	●	●	●	●	●	KN...B	KNO...B	Robust design	+	+	up to ±30	all	53, 58
–	–	–	●	–	●	●	●	●	●	●	KS	KSO	High load capacity	++	++	up to ±40	all	53, 60
–	–	–	●	–	●	●	●	●	●	●	KB	KBO	High precision	+	+++	–	KBS	53, 62
–	–	–	●	–	●	●	●	●	●	●	PAB	PABO	Plain bearing	+++	++	–	–	53, 64



Product overview

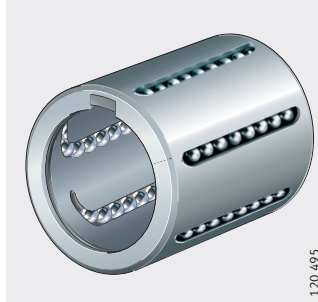
Linear bearings and linear bearing and housing units

Compact range

Linear ball bearings
With and without seals

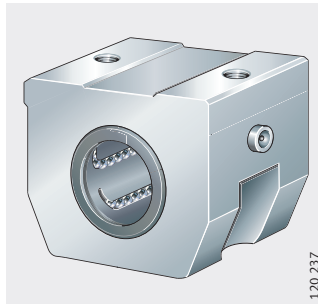
Features see page 56

KH, KH..-PP

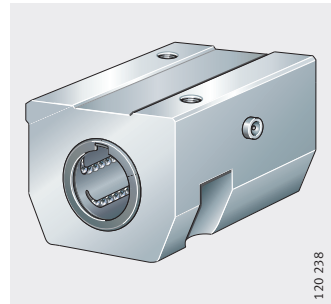


Closed units
Bearings mounted in single
or tandem arrangement

KGHK..-B-PP-AS

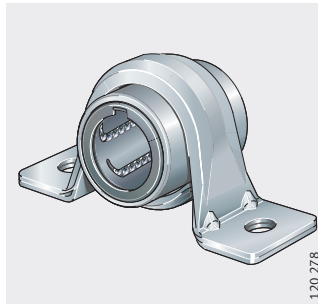


KTHK..-B-PP-AS

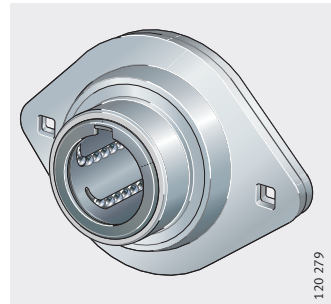


Adjustable units

KGHW..-PP

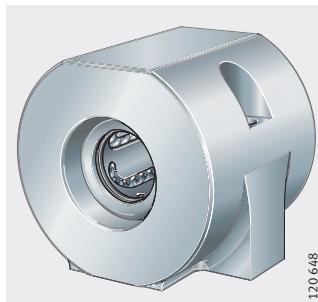


KGHW..-PP



Closed unit

KGHA..-PP



Light range

Linear ball bearings
Closed
or with segment cutout
With and without seals

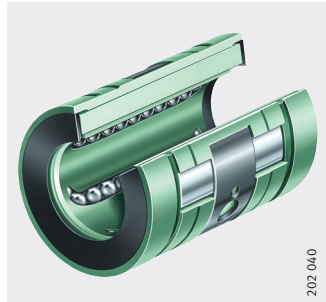
Features see page 58

KN..-B, KN..-B-PP



202 039

KNO..-B, KNO..-B-PP

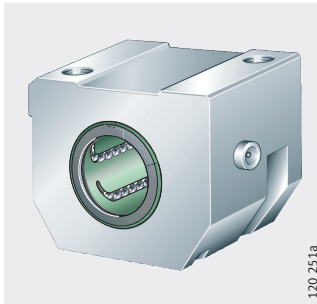


202 040



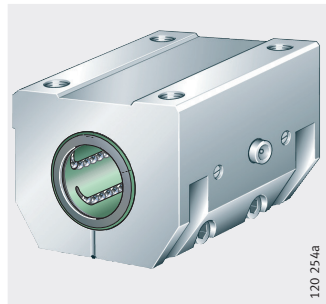
Closed units
Housing closed or slotted
Bearings mounted in single
or tandem arrangement

**KGN..-C-PP-AS,
KGNs..-C-PP-AS**



120 251a

**KTN..-C-PP-AS,
KTNS..-C-PP-AS**

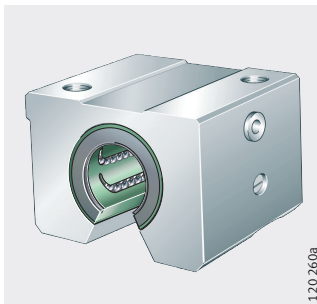


120 254a



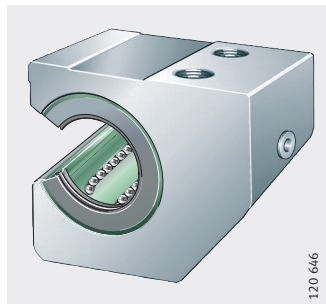
Units
with segment cutout
Housing not slotted or slotted

**KGNO..-C-PP-AS,
KGNOS..-C-PP-AS**



120 260a

**KGNC..-C-PP-AS,
KGNCs..-C-PP-AS**

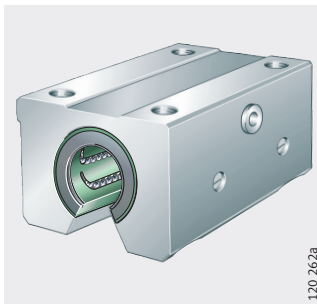


120 646



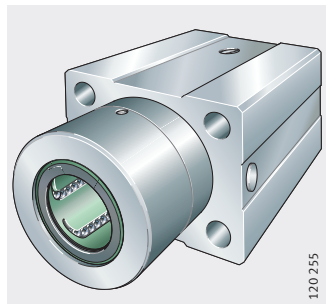
Bearings mounted
in tandem arrangement
Unit with centring collar

**KTNO..-C-PP-AS,
KTNOS..-C-PP-AS**



120 262a

KTFN..-C-PP-AS



120 255

Product overview

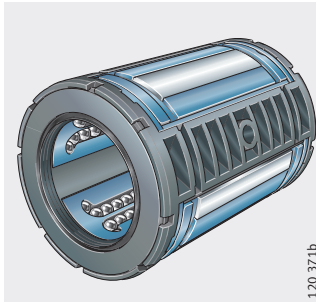
Linear bearings and linear bearing and housing units

Heavy duty range

Linear ball bearings
Closed
or with segment cutout
With and without seals

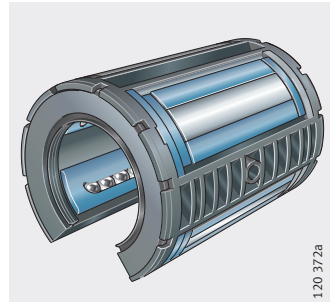
Features see page 60

KS, KS..-PP



120 371b

KSO, KSO..-PP

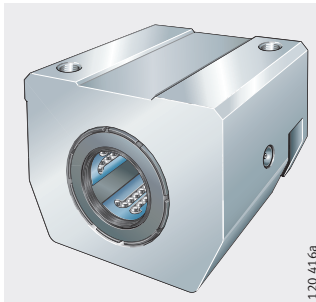


120 372a

Closed units
Housing closed
or slotted

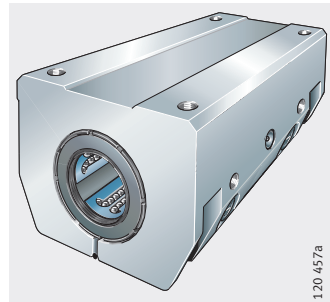
Bearings mounted in single
or tandem arrangement

**KGSNG..-PP-AS,
KGSNS..-PP-AS**



120 416a

**KTSG..-PP-AS,
KTSS..-PP-AS**

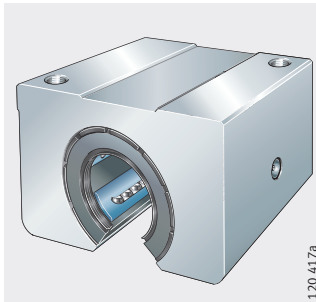


120 457a

Units
with segment cutout
Housing not slotted
or slotted

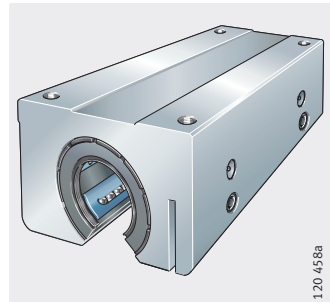
Bearings mounted in single
or tandem arrangement

**KGSNO..-PP-AS,
KGSNOS..-PP-AS**



120 417a

**KTSO..-PP-AS,
KTSOS..-PP-AS**



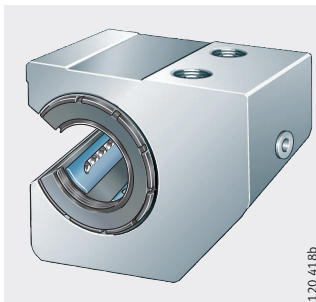
120 458a

Bearings mounted in single
or tandem arrangement

Housing not slotted
or slotted

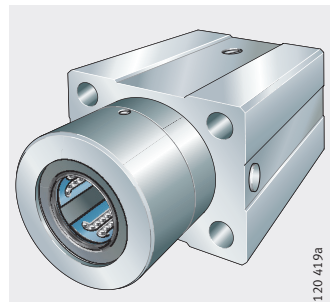
Unit with centring collar

**KGSC..-PP-AS,
KGSCS..-PP-AS**



120 418b

KTFS



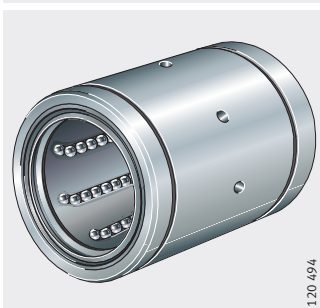
120 419a

Machined range

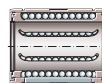
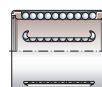
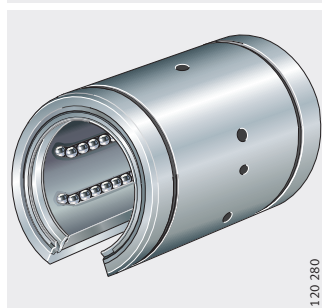
Linear ball bearings
 Closed
 or with slot
 With segment cutout
 With and without seals

Features see page 62

**KB, KB..-PP, KB..-PP-AS,
 KBS, KBS..-PP, KBS..-PP-AS**

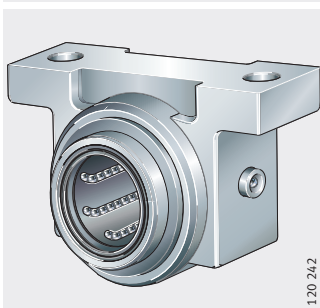


KBO, KBO..-PP, KBO..-PP-AS

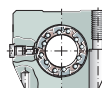
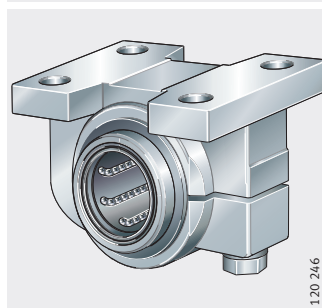


Closed units
 Housing closed
 or slotted

**KGB..-PP-AS,
 KGBS..-PP-AS**

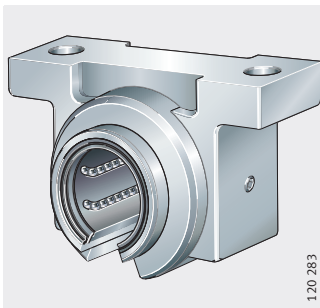


**KGBA..-PP-AS,
 KGBAS..-PP-AS**

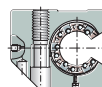
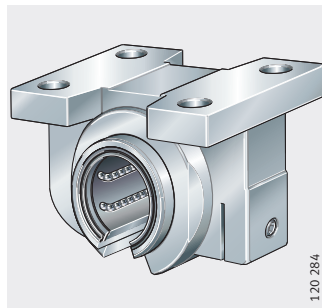


Units
 with segment cutout
 Housing not slotted
 or slotted

KGBO..-PP-AS

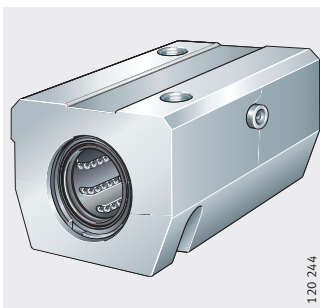


KGBAO..-PP-AS

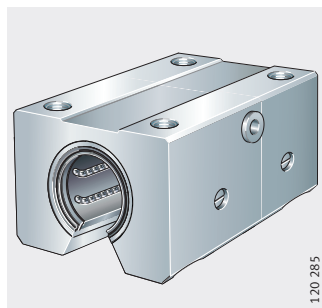


Closed units
 or units
 with segment output
 Bearings mounted in tandem
 arrangement

KTB..-PP-AS



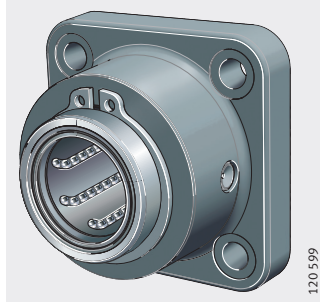
KTBO..-PP-AS



Product overview **Linear bearings and linear bearing and housing units**

Flanged housing unit
Closed design

KFB...PP-AS

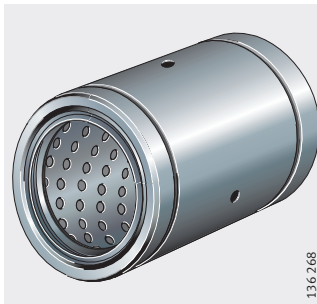


**Permaglide®
plain bearing range**

Linear plain bearings
Closed design
Sealed

Features see page 64

PAB...PP-AS

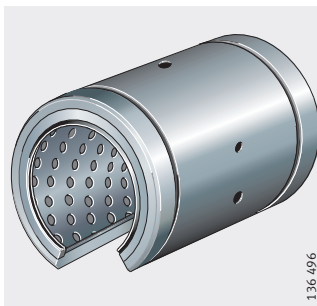


136 268



With segment cutout
Sealed

PABO...PP-AS

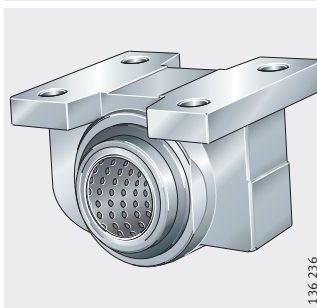


136 496



Linear plain bearing units
Closed design

PAGBA...PP-AS

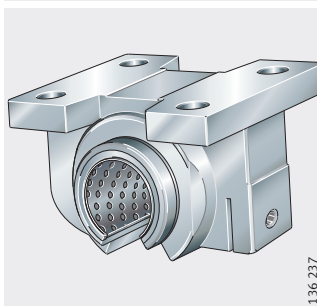


136 236



With segment cutout

PAGBAO...PP-AS



136 237



Linear bearings and linear bearing and housing units

Features Linear bearings and linear bearing and housing units are available in the compact, light, heavy duty, machined and plain bearing range. The bearings can support high loads while having a relatively low mass and allow the construction of linear guidance systems with unlimited travel.

Each series has quite specific characteristics that makes it particularly suitable for certain applications. These may include, for example, requirements for compensation of misalignments, low-friction running, high accelerations and travel speeds or long operating life.

The range, which has been constructed and expanded in accordance with a modular concept, provides the best technical and economic solution, in relation to each application, for bearing arrangements with shaft guidance systems.

Linear bearings Linear ball bearings and linear plain bearings are available in open or closed designs. The open design has a segment cut out and is intended for supported shafts. Several series allow, in conjunction with the corresponding housings, adjustment of the radial clearance in order to achieve clearance-free or preloaded guidance systems.

Compensation of misalignment Misalignment can be caused by tolerance defects, mounting errors or inaccuracies in the adjacent construction. Linear ball bearings of series KN..-B and KNO..-B can compensate static misalignment of up to $\pm 30'$, linear ball bearings of series KS and KSO up to $\pm 40'$, *Figure 1*.

Due to the self-alignment function, the balls run without difficulty into the load zone. At the same time, the load distribution over the whole ball row is more uniform. This leads to smoother running, allows higher accelerations and prevents overloading of the individual balls.

Overall, this means that the bearings can achieve higher loads and a longer operating life; if necessary, the adjacent construction can be designed to be smaller and more economical.

Attention! In order to fully utilise the basic load ratings given in the dimension table, the shaft raceway must be hardened (670 HV + 170 HV) and ground. Please observe the information in the section Design of bearing arrangements, page 32.

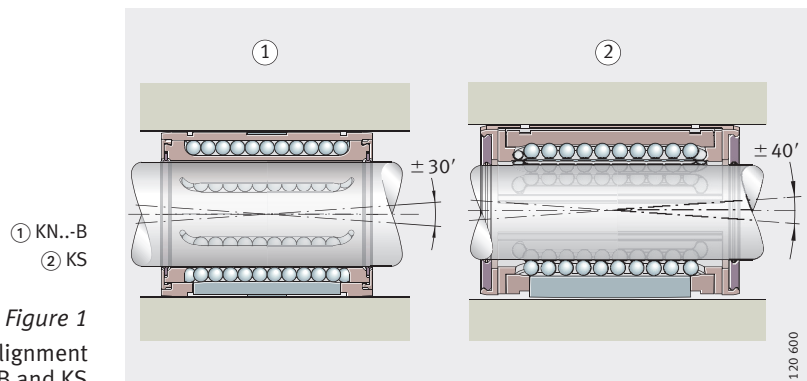


Figure 1
Compensation of misalignment
KN..-B and KS

Linear bearing and housing units

Linear ball bearings and plain bearings are also available in conjunction with INA housings as complete bearing units. The linear bearing is located in the housing by means of a radial fixing screw to prevent axial displacement.

The housings are made from a high rigidity, high strength aluminium alloy that allows the full load carrying capacity of the bearings fitted to be utilised. In the machined series, pressure diecast housings are also available.

Due to the comparatively low total mass, the units are particularly suitable for reduced mass designs with high loads and where higher accelerations and travel speeds are required.



Simple location

Threaded or counterbored holes in the housing allow straight-forward screw mounting on the adjacent construction, if necessary from below.

For rapid alignment, the housings have a locating edge. This also prevents distortion of the linear bearings when the housings are being mounted.

Centring holes allow rapid additional location by dowels on the adjacent construction.



Housing designs

The housings are available in closed design, with a segment cutout and in open, slotted and tandem versions (with and without a centring collar).

Closed design

In this variant, the bearing and housing are closed. High precision standard guidance systems with a fixed enveloping circle can thus be easily achieved.

With segment cutout

Open designs with a segment cutout are used where, in the case of long guidance systems, the shaft must be supported and the bearing arrangement must be highly rigid.

Slotted design

Closed designs and designs with a segment cutout are also available in several series with a slot. Slotted variants are suitable for clearance-free or preloaded guidance systems. The operating clearance is set by means of an adjusting screw.

Tandem design

The tandem version contains two linear bearings. As a result, the units have particularly high load carrying capacity. Tandem ball bearing and housing units are available in open and closed designs. Both variants are also available in the named design with a slot.

With centring collar

For special applications, there is also a tandem version with a centring collar for locating bores to H7.

Highly cost-effective

As a result of volume production in large quantities, the complete units are normally considerably more economical than customers' own designs.



Linear bearings and linear bearing and housing units

Sealing The bearings are available in an open version and with contact seals on both sides (suffix PP). The end face seals have two seal lips; the outer lip prevents the ingress of contamination, the inner lip retains the lubricant in the bearing.

Lubrication Due to the initial greasing with a high quality grease and the integral lubricant reservoir, the linear bearings are maintenance-free for many applications; if necessary, however, they can be relubricated. Linear ball bearings can be lubricated, depending on the design, via the openings in the outer ring or radial holes arranged in the centre of the bearing.

In the units, lubrication is carried out via a separate lubrication nipple in the housing; location of the bearing in the housing and the relubrication devices are thus separate from each other.

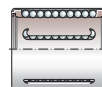
Operating temperature Bearings and housings can be used at operating temperatures from -30 °C to $+80\text{ °C}$.

Operating limits

The table shows the operating limits for linear bearings. Once the interrelationships of bearing size and design, load, operating clearance, location of bearings and lubrication have been checked, it may be possible in individual cases to use higher values. Please contact us in this case.

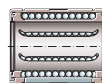
Attention!

Linear bearing and housing units should be allocated in accordance with the linear bearing fitted.



Dynamic values for linear bearings

Acceleration, speed	Linear bearing series				
	KH	KN-B	KB	KS	PAB
Acceleration in m/s^2	50	50	50	100	50
Speed in m/s	2	up to 5	up to 5	up to 5	up to 3

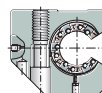
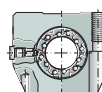


Suffixes

Suffixes for available designs: see table.

Available designs

Suffix	Description	Design
PP	Lip seals on both sides	Standard
PPL	Sealing strips on bearings with segment cutout	Available by agreement
AS	Bearing and unit with relubrication facility	Standard



Linear bearings and linear bearing and housing units

Compact range

Compact range

Linear ball bearings KH and linear ball bearing and housing units of the compact range have a small radial design envelope and are particularly economical. Their low radial section height automatically makes them attractive for applications in which only a small amount of radial space is available.

Due to the closed design, they are suitable for use on shafts.

Linear ball bearings

The bearings have an outer ring with openings. This contains a ball and cage assembly with a plastic cage. The outer ring is formed and hardened. The balls undergo return travel along the openings in the outer ring.

Seals

The bearings are available in an open version and with lip seals on both sides (suffix PP). The end face seals have two seal lips; the outer lip prevents the ingress of contamination, the inner lip retains the lubricant in the bearing.

Linear ball bearing and housing units

Linear ball bearing and housing units of the compact range are available with an integral bearing and, in the tandem version with particularly high load carrying capacity, with two bearings.

The housings are made from high strength aluminium.

The linear ball bearing and housing units KGHW..-PP and KGHWT..-PP are designed as plummer block and flanged housing units. These can support static misalignment and allow static self-alignment up to 3° by means of a ball cup.

Anti-corrosion protection

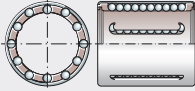
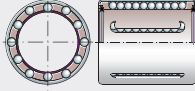
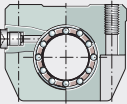
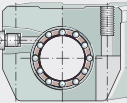
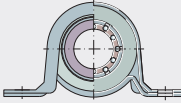
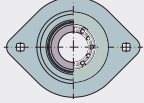
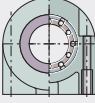
The housings are two-piece components made from sheet steel with a Corrotect® coating. The bearings and housing parts are packed separately. The bearing is firmly seated once it is fitted in the housing.

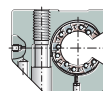
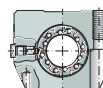
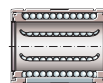
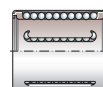
Further information

Further information is given on the following pages:

- dimension tables see page 65
- shafts see page 118
- shaft and support rail units see page 142
- accessories see page 160.

**Linear ball bearings
and linear ball bearing
and housing units,
compact range**

Series ¹⁾		Feature
KH	 120 506	<ul style="list-style-type: none"> ■ Linear ball bearing ■ Not sealed
KH...PP	 120 507	<ul style="list-style-type: none"> ■ Linear ball bearing ■ Lip seals on both sides
KGHK...PP-AS	 120 508	<ul style="list-style-type: none"> ■ Closed design ■ Relubrication facility
KTHK...PP-AS	 120 509	<ul style="list-style-type: none"> ■ Closed design ■ Tandem design ■ Relubrication facility
KGHW...-PP	 120 535	<ul style="list-style-type: none"> ■ Sheet steel housing, with Corrotect[®] coating ■ Self-aligning
KGHW...-PP	 120 536	<ul style="list-style-type: none"> ■ Sheet steel housing, with Corrotect[®] coating ■ Self-aligning
KGHA...-PP	 120 537	<ul style="list-style-type: none"> ■ Unit ■ Closed design

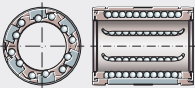
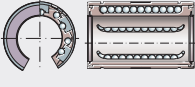
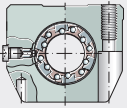
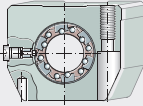
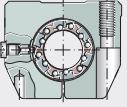
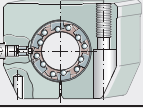
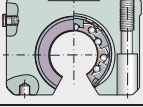
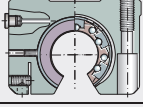
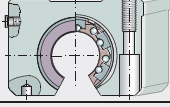
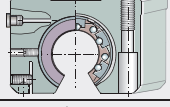
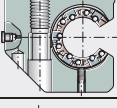
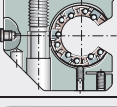
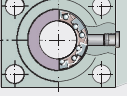


¹⁾ The suffix PP indicates that the bearing has lip seals on both sides.

Linear bearings and linear bearing and housing units

- Light range** The light range is available as linear ball bearings KN..-B and KNO..-B and as completely ready-to-fit linear ball bearing and housing units.
- In the appropriate housing, the bearings have adjustable clearance. In order to compensate misalignments arising from manufacturing tolerances, mounting errors and shaft deflection, the linear bearings of series KN..-B are self-aligning up to $\pm 30'$.
- Their robust construction allows operation even under aggressive operating conditions.
- The series KN..-B is of a closed construction and is designed for use on shafts. KNO..-B has a segment cutout and is used with shaft and support rail units.
- Linear ball bearings** Linear ball bearings KN..-B and KNO..-B comprise a plastic cage with inserted raceway plates. The plates are supported in the housing bore by means of a retaining ring. Due to the retaining ring, the plates can “rock” and thus compensate for static misalignments.
- Seals** The bearings are available in an open version and with contact seals on both sides (suffix PP). The end face seals have two seal lips; the outer lip prevents the ingress of contamination, the inner lip retains the lubricant in the bearing.
- Linear ball bearing and housing units** Linear ball bearing and housing units of the compact range are available with an integral bearing and, in the tandem version with particularly high load carrying capacity, with two bearings. The housings are made from high strength aluminium.
- The housings are available in a closed design, with a segment cutout for supported shafts and with or without a slot.
- In units with a slot, the radial clearance can be adjusted.
- All series have a locating edge and centring holes for dowel holes.
- The bearings are sealed on both sides, they have an initial greasing and can be relubricated via a lubrication nipple in the housing.
- Further information** Further information is given on the following pages:
- dimension tables see page 76
 - shafts see page 118
 - shaft and support rail units see page 142
 - accessories see page 160.

**Linear ball bearings
and linear ball bearing
and housing units,
light range**

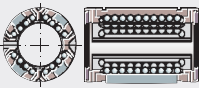
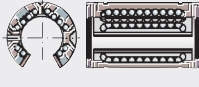
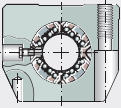
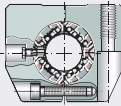
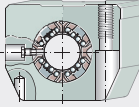
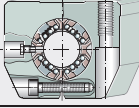
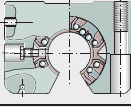
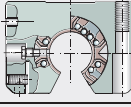
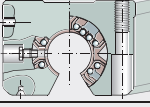
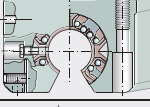
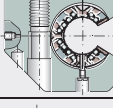
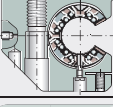
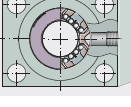
Series ¹⁾		Feature
KN...-B KN...-B-PP		<ul style="list-style-type: none"> ■ Linear ball bearings ■ Closed design ■ Self-aligning ■ With or without lip seals
KNO...-B KNO...-B-PP		<ul style="list-style-type: none"> ■ Linear ball bearings ■ With segment cutout ■ Self-aligning ■ With or without lip seals
KGN...-C-PP-AS		<ul style="list-style-type: none"> ■ Closed design ■ Relubrication facility
KTN...-C-PP-AS		<ul style="list-style-type: none"> ■ Closed design ■ Tandem arrangement ■ Relubrication facility
KGNS...-C-PP-AS		<ul style="list-style-type: none"> ■ Closed design ■ Slotted housing ■ Relubrication facility
KTNS...-C-PP-AS		<ul style="list-style-type: none"> ■ Tandem arrangement ■ Slotted housing ■ Relubrication facility
KGNO...-C-PP-AS		<ul style="list-style-type: none"> ■ With segment cutout ■ Relubrication facility
KGNO...-C-PP-AS		<ul style="list-style-type: none"> ■ With segment cutout ■ Slotted housing ■ Relubrication facility
KTNO...-C-PP-AS		<ul style="list-style-type: none"> ■ With segment cutout ■ Tandem arrangement ■ Relubrication facility
KTNO...-C-PP-AS		<ul style="list-style-type: none"> ■ With segment cutout ■ Slotted housing ■ Tandem arrangement ■ Relubrication facility
KGNC...-C-PP-AS		<ul style="list-style-type: none"> ■ With segment cutout ■ Relubrication facility
KGNC...-C-PP-AS		<ul style="list-style-type: none"> ■ With segment cutout ■ Slotted housing ■ Relubrication facility
KTFN...-PP-AS		<ul style="list-style-type: none"> ■ With centring collar ■ Tandem arrangement ■ Relubrication facility

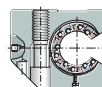
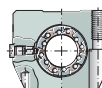
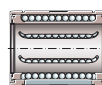
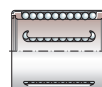
¹⁾ The suffix PP indicates that the bearing has lips seals on both sides.

Linear bearings and linear bearing and housing units

Heavy duty range	Linear ball bearings of the heavy duty range KS and KSO and the corresponding ball bearing and housing units have particularly high load carrying capacity and have an angular adjustment facility for compensation of misalignments. They have very good running characteristics.
Linear ball bearings	<p>Linear ball bearings KS and KSO comprise a plastic cage with loosely retained segments. The double row segments with crowned raceway plates can realign themselves in all directions and thus compensate misalignments. Since the complete segment undergoes realignment, there is no disruption to the recirculation of the balls. This results in uniformly low displacement resistance.</p> <p>The series KS is of a closed construction and is designed for use on shafts. KSO has a segment cutout and is used in conjunction with shaft and support rail units.</p>
Seals	The bearings are available with contact seals or gap seals. The end face contact seals have two seal lips; the outer lip prevents the ingress of contamination, the inner lip retains the lubricant in the bearing.
Linear ball bearing and housing units	<p>Linear ball bearing and housing units of the heavy duty range are available with an integral bearing and, in the tandem version with particularly high load carrying capacity, with two bearings. The housings are made from high strength aluminium.</p> <p>The housings are available in a closed design, with a segment cutout for supported shafts and with or without a slot. In designs with a slot, the radial clearance can be adjusted by means of an adjusting screw.</p> <p>All series have a locating edge and centring holes for dowel holes. The bearings are sealed on both sides, they have an initial greasing and can be relubricated via a lubrication nipple in the housing.</p>
Further information	<p>Further information is given on the following pages:</p> <ul style="list-style-type: none">■ dimension tables see page 90■ shafts see page 118■ shaft and support rail units see page 142■ accessories see page 160.

**Linear ball bearings
and linear ball bearing
and housing units,
heavy duty range**

Series ¹⁾		Feature
KS KS...PP		<ul style="list-style-type: none"> ■ Linear ball bearings ■ Self-aligning ■ With or without lip seals
KSO KSO...PP		<ul style="list-style-type: none"> ■ Linear ball bearings ■ With segment cutout ■ Self-aligning ■ With or without lip seals
KGSNG...PP-AS		<ul style="list-style-type: none"> ■ Closed design ■ Relubrication facility
KGSNS...PP-AS		<ul style="list-style-type: none"> ■ Closed design ■ Slotted housing ■ Relubrication facility
KTSG...PP-AS		<ul style="list-style-type: none"> ■ Closed design ■ Tandem arrangement ■ Relubrication facility
KTSS...PP-AS		<ul style="list-style-type: none"> ■ Closed design ■ Tandem arrangement ■ Slotted housing ■ Relubrication facility
KGSNO...PP-AS		<ul style="list-style-type: none"> ■ With segment cutout ■ Relubrication facility
KGSNOS...PP-AS		<ul style="list-style-type: none"> ■ With segment cutout ■ Slotted housing ■ Relubrication facility
KTSO...PP-AS		<ul style="list-style-type: none"> ■ With segment cutout ■ Tandem arrangement ■ Relubrication facility
KTSOS...PP-AS		<ul style="list-style-type: none"> ■ With segment cutout ■ Tandem arrangement ■ Slotted housing ■ Relubrication facility
KGSC...PP-AS		<ul style="list-style-type: none"> ■ Open at side ■ Relubrication facility
KGSCS...PP-AS		<ul style="list-style-type: none"> ■ Open at side ■ Slotted housing ■ Relubrication facility
KTFS...PP-AS		<ul style="list-style-type: none"> ■ With centring collar ■ Tandem arrangement ■ Relubrication facility

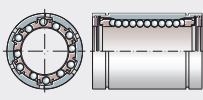
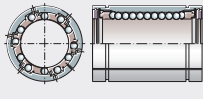
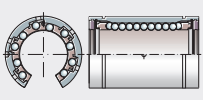
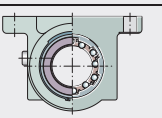
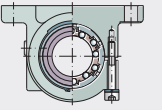
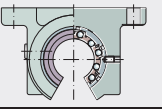
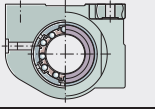
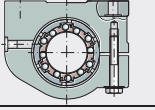
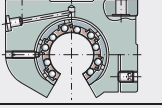
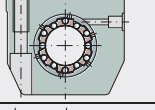
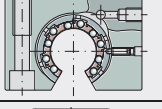
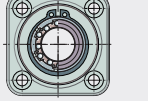


¹⁾ The suffix PP indicates that the bearing has lip seals on both sides.

Linear bearings and linear bearing and housing units

Machined range	Linear ball bearings of the machined range KB, KBS and KBO and the corresponding linear ball bearing and housing units have high precision and are particularly rigid. They have excellent running characteristics.
Linear ball bearings	<p>Linear ball bearings KB, KBS and KBO comprise a hardened and ground outer ring in which a ball and cage assembly with a plastic cage is integrated.</p> <p>The balls are guided with high precision throughout the return area by a special spring washer. This ensures that the displacement resistance remains uniformly low even under difficult operating conditions and irrespective of the mounting position.</p> <p>The series KB is of a closed construction and is designed for use on shafts. KBO has a segment cutout and is used in conjunction with shaft and support rail units. KBS has a slot for adjustment of the radial clearance.</p>
Seals	The bearings have contact seals or gap seals.
Linear ball bearing and housing units	<p>Linear ball bearing and housing units of the machined range are available with an integral bearing and, in the tandem version with particularly high load carrying capacity, with two bearings.</p> <p>The housings are made from high strength aluminium or are pressure diecast.</p> <p>The housings are available in a closed design, with a segment cutout for supported shafts and with or without a slot. In designs with a slot, the radial clearance can be adjusted by means of an adjusting screw.</p> <p>All series have a locating edge and centring holes for dowel holes.</p> <p>The bearings are sealed on both sides, they have an initial greasing and can be relubricated via a lubrication nipple in the housing.</p>
Further information	<p>Further information is given on the following pages:</p> <ul style="list-style-type: none">■ dimension tables see page 104■ shafts see page 118■ shaft and support rail units see page 142■ accessories see page 160.

**Linear ball bearings
and linear ball bearing
and housing units,
machined range**

Series ¹⁾²⁾		Feature
KB KB...PP KB...PP-AS		<ul style="list-style-type: none"> Linear ball bearings With or without lip seals depending on the design Relubrication facility
KBS KBS...PP KBS...PP-AS		<ul style="list-style-type: none"> Linear ball bearings With or without lip seals depending on the design Relubrication facility Slotted design
KBO KBO...PP KBO...PP-AS		<ul style="list-style-type: none"> Linear ball bearings With or without lip seals depending on the design Relubrication facility With segment cutout
KGB...PP-AS		<ul style="list-style-type: none"> Closed design Relubrication facility
KGBS...PP-AS		<ul style="list-style-type: none"> Closed design Slotted housing Relubrication facility
KGBO...PP-AS		<ul style="list-style-type: none"> With segment cutout Relubrication facility
KGBA...PP-AS		<ul style="list-style-type: none"> Closed design Relubrication facility
KGBAS...PP-AS		<ul style="list-style-type: none"> Closed design Slotted housing Relubrication facility
KGBAO...PP		<ul style="list-style-type: none"> With segment cutout Relubrication facility
KTB...PP-AS		<ul style="list-style-type: none"> Closed design Tandem arrangement Relubrication facility
KTBO...PP-AS		<ul style="list-style-type: none"> With segment cutout Tandem arrangement Relubrication facility
KFB...PP-AS		<ul style="list-style-type: none"> Closed design Relubrication facility



¹⁾ The suffix PP indicates that the bearing has lip seals on both sides.
²⁾ Bearings and units with the suffix AS can be relubricated.

Linear bearings and linear bearing and housing units

Permaglide® plain bearing range

Linear plain bearings PAB and PABO and the corresponding plain bearing units have very high load carrying capacity, are extremely robust and have particularly low running noise. They have excellent emergency running characteristics.

Linear plain bearings

Linear plain bearings PAB and PABO comprise an outer ring made from high strength aluminium into which Permaglide® plain bearing bushes PAP..-P20 are fixed by adhesive.

The series PAB is of a closed construction and is designed for use on shafts. PABO has a segment cutout and is used in conjunction with shaft and support rail units.

Attention!

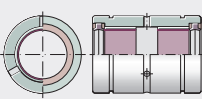
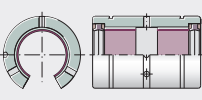
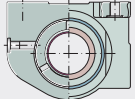
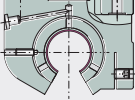
Permaglide® bushes must not be used in conjunction with the special coating Corrotect®. Crevice corrosion may occur that would impair the function of the bearing.

Further information

Further information is given on the following pages:

- dimension tables see page 114
- shafts see page 118
- shaft and support rail units see page 142
- accessories see page 160.

Linear plain bearings and linear plain bearing units, Permaglide® plain bearing range

Series ¹⁾		Feature
PAB..-PP-AS		<ul style="list-style-type: none"> ■ Closed design ■ Lip seals on both sides ■ Relubrication facility
PABO..-PP-AS		<ul style="list-style-type: none"> ■ With segment cutout ■ Lip seals on both sides ■ Relubrication facility
PAGBA..-PP-AS		<ul style="list-style-type: none"> ■ Closed design ■ Relubrication facility
PAGBAO..-PP-AS		<ul style="list-style-type: none"> ■ With segment cutout ■ Slotted housing ■ Relubrication facility

¹⁾ The suffix PP indicates that the bearing has lip seals on both sides.

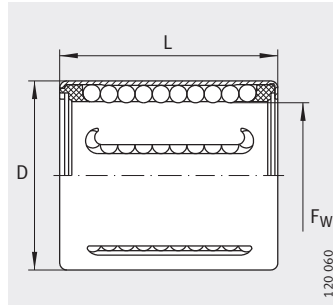
Compact range

Linear ball bearings

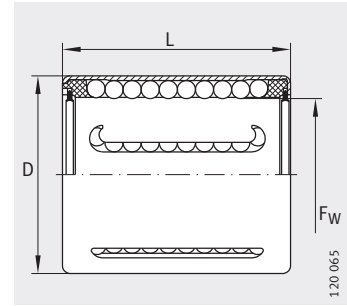
Unsealed

or sealed

Relubrication facility



KH



KH..-PP

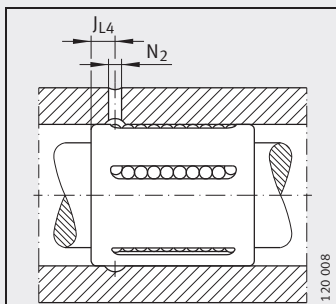


Dimension table · Dimensions in mm

Designation		Mass m g	Dimensions			Mounting dimensions		Basic load ratings ¹⁾			
2)	3)		F _w	D	L	J _{L4}	N ₂	dyn. C _{0 min} N	stat. C _{0 min} N	dyn. C _{0 max} N	stat. C _{0 max} N
KH06	KH06-PP	7	6	12	22	4	2	340	240	390	340
KH08	KH08-PP	12	8	15	24	6	2	410	280	475	400
KH10	KH10-PP	14,5	10	17	26	6	2,5	510	370	590	520
KH12	KH12-PP	18,5	12	19	28	6	2,5	670	510	800	740
KH14	KH14-PP	20,5	14	21	28	6	2,5	690	520	830	760
KH16	KH16-PP	27,5	16	24	30	7	2,5	890	620	1060	910
KH20	KH20-PP	32,5	20	28	30	7	2,5	1 110	790	1 170	1 010
KH25	KH25-PP	66	25	35	40	8	2,5	2 280	1 670	2 420	2 130
KH30	KH30-PP	95	30	40	50	8	2,5	3 300	2 700	3 300	3 100
KH40	KH40-PP	182	40	52	60	9	2,5	5 300	4 450	5 300	4 950
KH50	KH50-PP	252	50	62	70	9	2,5	6 800	6 300	6 800	7 000

Corrosion-resistant designs have the suffix -RR.
This must be stated when ordering.

- 1) The basic load ratings are only valid for hardened (670 HV + 170 HV) and ground shaft raceways.
- 2) With preservative.
- 3) With initial greasing, sealed on both sides.

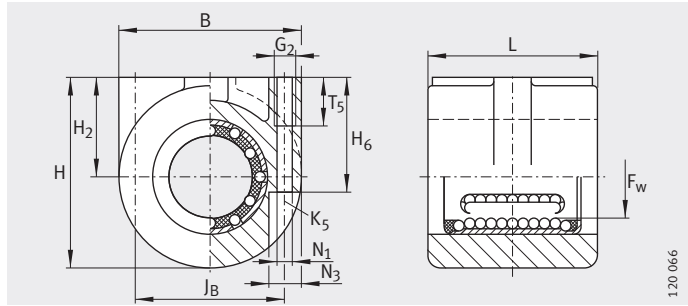


Mounting dimensions

Compact range

Linear ball bearing and housing units

Sealed
Greased



KGHA..-PP

120 066

Dimension table - Dimensions in mm

Designation	Mass m ≈g	Dimensions				
		F _w	H ₂ ±0,015	H	B	L +0,5
KGHA10-PP	108	10	15	29	29	33
KGHA12-PP	258	12	20	39	42	37
KGHA14-PP	246	14	20	41	42	37
KGHA16-PP	228	16	20	41	42	37
KGHA20-PP	303	20	25	48,5	47	39
KGHA25-PP	496	25	30	57,5	55	49
KGHA30-PP	860	30	35	67,5	65	59
KGHA40-PP	1 434	40	45	84	78	71
KGHA50-PP	2 120	50	50	96	92	81

- 1) The basic load ratings are only valid for hardened (670 HV + 170 HV) and ground shaft raceways.
- 2) For fixing screws ISO 4 762-8.8.
If there is a possibility of settling, the screws should be secured against rotation.

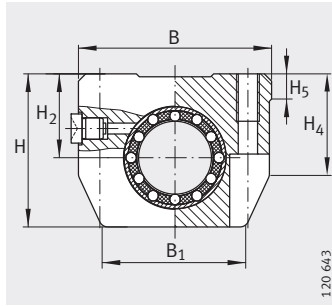


Mounting dimensions							Basic load ratings ¹⁾	
H ₆	T ₅	J _B ±0,1	G ₂	N ₁	N ₃	K ₅ ²⁾	dyn. C N	stat. C ₀ N
18,5	10	23	M4	3,25	6,1	M3	510	370
27	15	32	M6	5,1	8,1	M4	670	510
27	15	32	M6	5,1	8,1	M4	690	520
27	15	32	M6	5,1	8,1	M4	890	620
29	15	38	M6	5,1	8,1	M4	1 110	790
35	15	46	M6	5,1	8,1	M4	2 280	1 670
39	20	54	M8	6,7	11,1	M6	3 300	2 700
49	20	66	M8	6,7	11,1	M6	5 300	4 450
59	25	78	M10	8,5	15,125	M8	6 800	6 300

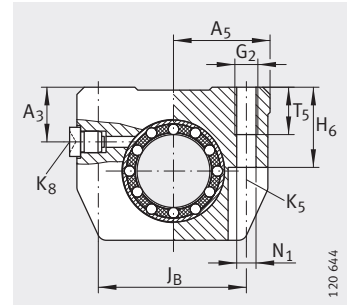
Compact range

Linear ball bearing and housing units

Sealed
Greased,
with relubrication facility



KGHK..-B-PP-AS

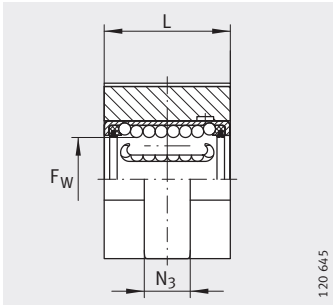


KGHK..-B-PP-AS

Dimension table - Dimensions in mm

Designation	Mass m ≈g	Dimensions				Mounting dimensions		
		F _w	B	L	H	J _B	B ₁	A ₅
KGHK06-B-PP-AS	40	6	32	22,2	27	±0,15	25	16
KGHK08-B-PP-AS	50	8	32	24,2	27	±0,15	25	16
KGHK10-B-PP-AS	70	10	40	26,2	33	±0,15	32	20
KGHK12-B-PP-AS	80	12	40	28,2	33	±0,15	32	20
KGHK14-B-PP-AS	100	14	43	28,2	36,5	±0,15	34	21,5
KGHK16-B-PP-AS	110	16	43	30,2	36,5	±0,15	34	21,5
KGHK20-B-PP-AS	150	20	53	30,2	42,5	±0,15	40	26,5
KGHK25-B-PP-AS	270	25	60	40,2	52,5	±0,15	44	30
KGHK30-B-PP-AS	400	30	67	50,2	60	±0,15	49,6	33,5
KGHK40-B-PP-AS	750	40	87	60,2	73,5	±0,15	63	43,5
KGHK50-B-PP-AS	1 250	50	103	70,2	92	±0,15	74	51,5

- 1) The basic load ratings are only valid for hardened (670 HV + 170 HV) and ground shaft raceways.
- 2) For fixing screws ISO 4 762-8.8.
If there is a possibility of settling, the screws should be secured against rotation.
- 3) Lubrication nipple see page 31.



KGHK..-B-PP-AS

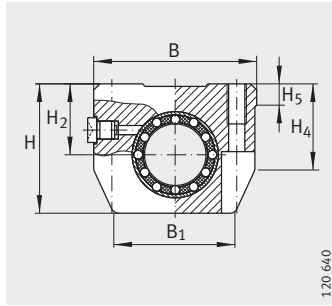
											Basic load ratings ¹⁾	
H ₂ +0,010 -0,014	H ₄	H ₅	T ₅	H ₆	A ₃	G ₂	N ₁	N ₃	K ₅ ²⁾	K ₈ ³⁾	dyn. C N	stat. C ₀ N
13	20,6	5	9	13	9	M4	3,4	7	M3	NIPA1	340	240
14	20,6	5	9	13	9	M4	3,4	7	M3	NIPA1	410	280
16	25,1	5	11	16	11	M5	4,3	10	M4	NIPA1	510	370
17	25,1	5	11	16	11	M5	4,3	10	M4	NIPA1	670	510
18	28,1	6,9	11	18	13	M5	4,3	10	M4	NIPA1	690	520
19	28,1	6,9	11	18	13	M5	4,3	10	M4	NIPA1	890	620
23	29,8	7,4	13	22	15	M6	5,3	11	M5	NIPA2	1 110	790
27	36,6	9,9	18	26	17,5	M8	6,6	15	M6	NIPA2	2 280	1 670
30	42,7	8	18	29	18	M8	6,6	15	M6	NIPA2	3 300	2 700
39	49,7	12,8	22	38	23	M10	8,4	18	M8	NIPA2	5 300	4 450
47	62,3	10,9	26	46	28	M12	10,5	20	M10	NIPA2	6 800	6 300



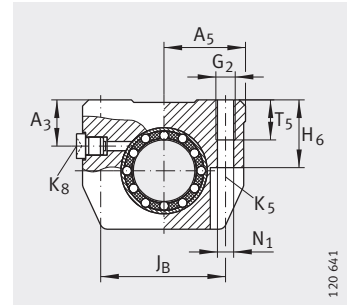
Compact range

Linear ball bearing and housing units

Tandem arrangement
Sealed
Greased,
with relubrication facility



KTHK..-B-PP-AS



KTHK..-B-PP-AS

Dimension table - Dimensions in mm

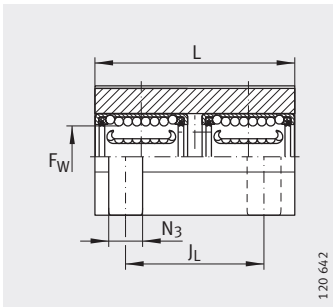
Designation	Mass m ≈g	Dimensions				Mounting dimensions			
		F _w	B	L	H	J _B	B ₁	A ₅	J _L ³⁾
KTHK12-B-PP-AS	170	12	40	60	33	29	32	20	35
KTHK16-B-PP-AS	230	16	43	65	36,5	34	34	21,5	40
KTHK20-B-PP-AS	320	20	53	65	42,5	40	40	26,5	45
KTHK25-B-PP-AS	580	25	60	85	52,5	48	44	30	55
KTHK30-B-PP-AS	850	30	67	105	60	53	49,6	33,5	70
KTHK40-B-PP-AS	1 600	40	87	125	73,5	69	63	43,5	85
KTHK50-B-PP-AS	2 700	50	103	145	92	82	74	51,5	100

¹⁾ The basic load ratings are only valid for hardened (670 HV + 170 HV) and ground shaft raceways and where the two linear ball bearings are subjected to equal loading.

²⁾ For fixing screws ISO 4762-8.8.
If there is a possibility of settling, the screws should be secured against rotation.

³⁾ Dimension J_L and lubrication hole symmetrical to the bearing length L.

⁴⁾ Lubrication nipple see page 31.



KTHK...B-PP-AS

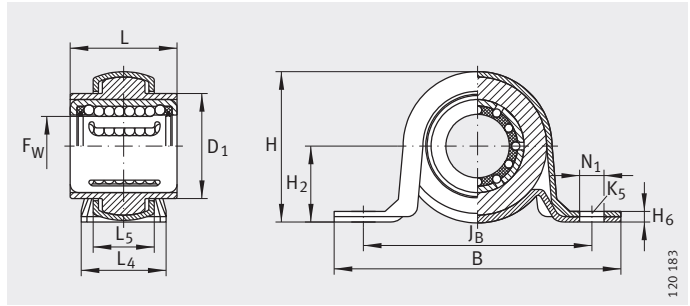


											Basic load ratings ¹⁾	
H ₂ +0,010 -0,014	H ₄	H ₅	T ₅	H ₆	A ₃	G ₂	N ₁	N ₃	K ₅ ²⁾	K ₈ ⁴⁾	dyn. C N	stat. C ₀ N
17	25,1	5	11	16	11	M5	4,3	10	M4	NIPA1	1 090	1 020
19	28,1	6,9	11	18	13	M5	4,3	10	M4	NIPA1	1 440	1 240
23	29,8	7,4	13	22	15	M6	5,3	11	M5	NIPA2	1 800	1 580
27	36,6	9,9	18	26	17,5	M8	6,6	11	M6	NIPA2	3 700	3 350
30	42,7	8	18	29	18	M8	6,6	15	M6	NIPA2	5 400	5 400
39	49,7	12,8	22	38	23	M10	8,4	18	M8	NIPA2	8 600	6 900
47	62,3	10,9	26	46	28	M12	10,5	20	M10	NIPA2	11 000	12 600

Compact range

Linear ball bearing and housing units

- Self-aligning
- Sealed
- Greased



KGHW..-PP

120 183

Dimension table - Dimensions in mm

Designation	Mass m ≈g	Dimensions			
		F _w	B	L	H
KGHW16-PP	220	16	85,7 ±0,5	30	43,2
KGHW20-PP	190	20	85,7	30	43,2
KGHW25-PP	450	25	108	40	56,5

¹⁾ The basic load ratings are only valid for hardened (670 HV + 170 HV) and ground shaft raceways.



Mounting dimensions

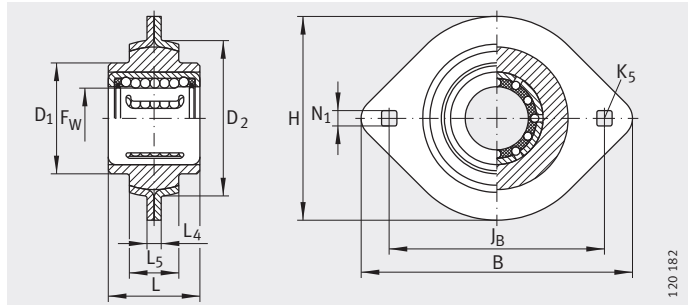
Basic load ratings¹⁾

J_B	L_4	L_5	D_1	H_2	H_6	N_1	K_5	dyn. C N	stat. C_0 N
$\pm 0,25$				$\pm 0,2$					
68,3	25,4	18,8	32	22,2	3	9,5	M8	890	620
68,3	25,4	18,8	32	22,2	3	9,5	M8	1 110	790
86	32	23,5	40	28,6	4	11,5	M10	2 280	1 670

Compact range

Linear ball bearing and housing units

- Self-aligning
- Sealed
- Greased



KGHWT..-PP

Dimension table - Dimensions in mm

Designation	Mass m ≈g	Dimensions			
		F _w	B	L	H
KGHWT16-PP	220	16	81	30	58,7
KGHWT20-PP	190	20	81	30	58,7
KGHWT25-PP	320	25	90,5	40	66

- 1) The basic load ratings are only valid for hardened (670 HV + 170 HV) and ground shaft raceways.
- 2) Fixing screws (to DIN 603, mushroom head square neck bolt) should be secured against rotation if there is a possibility of settling.



Mounting dimensions							Basic load ratings ¹⁾	
l_B	L_4	L_5	D_1	D_2	N_1	$K_5^{2)}$	dyn. C N	stat. C_0 N
$\pm 0,15$	$\pm 0,5$	+1						
63,5	4	14	32	44	7	M6	890	620
63,5	4	14	32	44	7	M6	1 110	790
71,5	4,4	16	40	51	8,7	M8	2 280	1 670

Light range

Linear ball bearings

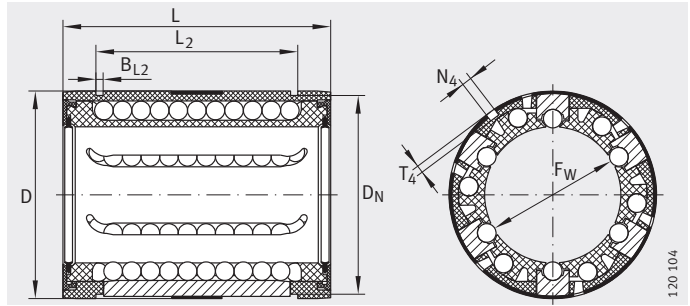
Self-aligning

Closed

or with segment cutout

Unsealed or sealed

Relubrication facility



KN..-B-PP, KN..-B

Dimension table - Dimensions in mm

Designation				Mass m ≈ g	Dimensions			Mounting dimensions	
					F _w	D	L	B ₂ ³⁾	L ₂
KN12-B-PP	KN12-B	-	-	20	12	22	32	-	22,6
-	-	KNO12-B-PP	KNO12-B					6,5	-
KN16-B-PP	KN16-B	-	-	30	16	26	36	-	24,6
-	-	KNO16-B-PP	KNO16-B					9	-
KN20-B-PP	KN20-B	-	-	60	20	32	45	-	31,2
-	-	KNO20-B-PP	KNO20-B					9	-
KN25-B-PP	KN25-B	-	-	130	25	40	58	-	43,7
-	-	KNO25-B-PP	KNO25-B					11,5	-
KN30-B-PP	KN30-B	-	-	190	30	47	68	-	51,7
-	-	KNO30-B-PP	KNO30-B					14	-
KN40-B-PP	KN40-B	-	-	350	40	62	80	-	60,3
-	-	KNO40-B-PP	KNO40-B					19	-
KN50-B-PP	KN50-B	-	-	670	50	75	100	-	77,3
-	-	KNO50-B-PP	KNO50-B					22,5	-

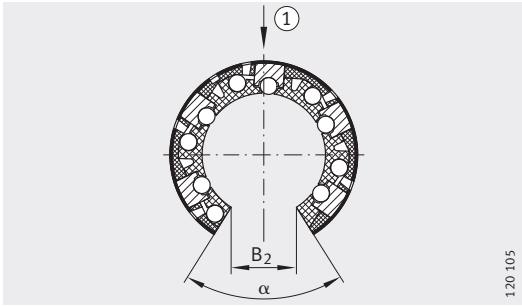
1) The basic load ratings are only valid for hardened (670 HV + 170 HV) and ground shaft raceways.

2) Basic load rating in main load direction.

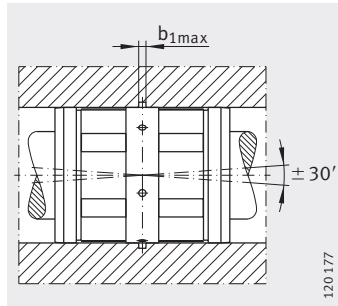
3) Dimension B₂ on diameter F_w.

4) Hole position symmetrical to bearing length L.

5) Not included in delivery, must be ordered separately.



120 105



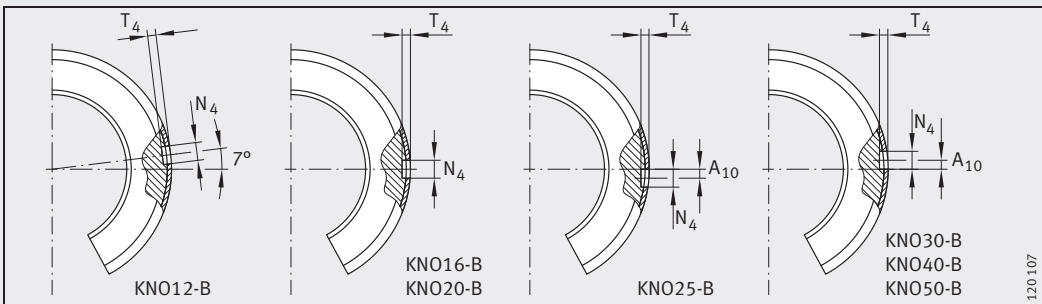
120 177

KNO..-B-PP, KNO..-B
 ① Main load direction

Self-aligning up to $\pm 30'$



B _{L2}	D _N	T ₄	A ₁₀	N ₄ ⁴⁾	α	Ball rows		Basic load ratings ¹⁾				Accessories ⁵⁾
						b _{1 max}	Quantity	dyn. C _{min} N	stat. C _{0 min} N	dyn. C _{max} N	stat. C _{0 max} N	Suitable retaining ring DIN 471
1,3	21	0,7	-	3	-	1,5	5	730	510	870	740	22X1,2
-	-				66		4	-	-	840 ²⁾	640 ²⁾	-
1,3	25	0,7	-	3	-	1,5	5	870	620	1040	910	26X1,2
-	-				68		4	-	-	1000 ²⁾	750 ²⁾	-
1,6	30,7	0,9	-	3	-	2,5	6	1730	1230	1830	1570	32X1,5
-	-				55		5	-	-	1740 ²⁾	1240 ²⁾	-
1,85	38,5	1,4	-	3	-	2,5	6	3100	2220	3250	2850	42X1,75
-	-		1,5		57		5	-	3100 ²⁾	2260 ²⁾	-	
1,85	44,7	2,2	-	3	-	2,5	6	3750	2850	3950	3650	48X1,75
-	-		2		57		5	-	3750 ²⁾	2850 ²⁾	-	
2,15	59,4	2,2	-	3	-	3	6	6300	4350	6700	5600	63X2
-	-		1,5		56		5	-	6300 ²⁾	4350 ²⁾	-	
2,65	71,4	2,3	-	5	-	3	6	9300	6500	9800	8300	75X2,5
-	-		2,5		54		5	-	9300 ²⁾	6500 ²⁾	-	



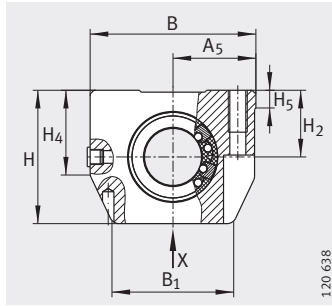
Fixing holes

120 107

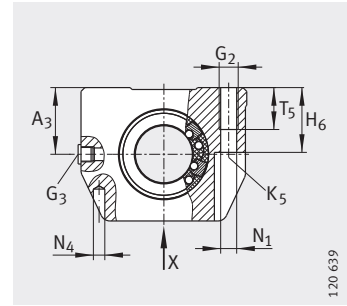
Light range

Linear ball bearing and housing units

Closed or with slot
Sealed
Greased,
with relubrication facility



KGN...-C-PP-AS, KGNS...-C-PP-AS



KGN...-C-PP-AS, KGNS...-C-PP-AS

Dimension table - Dimensions in mm

Designation	Mass m ≈g	Dimensions				Mounting dimensions					
		F _W	B	L	H	J _B	B ₁	A ₅	J _L ⁴⁾	H ₂	A ₃
KG12-C-PP-AS	100	12	43	32	35	32	34	21,5	23	18	18
KGNS12-C-PP-AS											
KG16-C-PP-AS	170	16	53	37	42	40	40	26,5	26	22	22
KGNS16-C-PP-AS											
KG20-C-PP-AS	270	20	60	45	50	45	44	30	32	25	25
KGNS20-C-PP-AS											
KG25-C-PP-AS	560	25	78	58	60	60	59,5	39	40	30	30
KGNS25-C-PP-AS											
KG30-C-PP-AS	830	30	87	68	70	68	63	43,5	45	35	35
KGNS30-C-PP-AS											
KG40-C-PP-AS	1 550	40	108	80	90	86	76	54	58	45	45
KGNS40-C-PP-AS											
KG50-C-PP-AS	2 700	50	132	100	105	108	90	66	50	50	50
KGNS50-C-PP-AS											

¹⁾ The basic load ratings are only valid for hardened (670 HV + 170 HV) and ground shaft raceways.

²⁾ Basic load rating in main load direction.

³⁾ For fixing screws ISO 4 762-8.8.

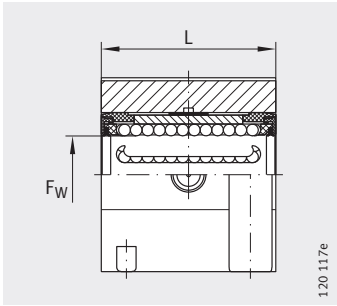
If there is a possibility of settling, the screws should be secured against rotation.

⁴⁾ Dimensions J_L and lubrication hole symmetrical to bearing length L.

⁵⁾ Lubrication hole closed off using plastic plug.

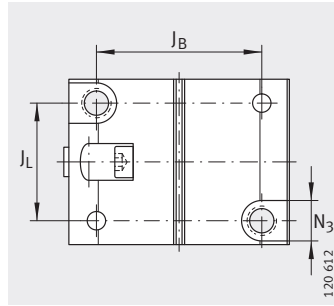
Lubrication nipple, designs and dimensions see page 30.

⁶⁾ Centring for dowel hole.



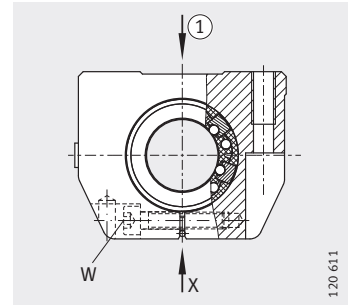
KGNS..-C-PP-AS

120 117e



KGNS..-C-PP-AS
View X

120 612



① Main load direction
View X

120 611

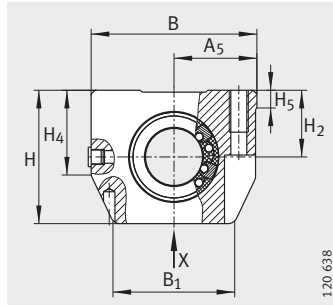


											Ball rows Quantity	Basic load ratings ¹⁾²⁾	
H ₅	H ₄	T ₅	H ₆	G ₂	N ₁	N ₄ ⁶⁾	N ₃	K ₅ ³⁾	G ₃ ⁴⁾⁵⁾	Width across flats W		dyn. C N	stat. C ₀ N
6	25,5	11	16,5	M5	4,3	4	8	M4	M6	— 2,5	5	780	560
7	28	13	21	M6	5,3	4	10	M5	M6	— 3	5	1 000	750
7,5	33	18	24	M8	6,6	5	11	M6	M6	— 4	6	1 740	1 240
8,5	40	22	29	M10	8,4	6	15	M8	M8X1	— 5	6	3 100	2 230
9,5	44,5	22	34	M10	8,4	6	15	M8	M8X1	— 5	6	3 800	2 900
11	56	26	44	M12	10,5	8	18	M10	M8X1	— 6	6	6 300	4 350
11	60	35	49	M16	13,5	10	20	M12	M8X1	— 8	6	9 300	6 500

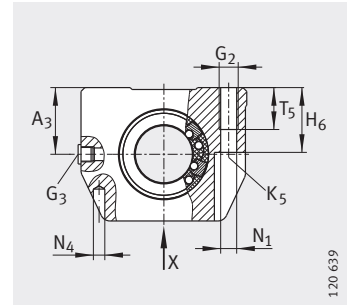
Light range

Linear ball bearing and housing units

Tandem arrangement
 Closed or with slot
 Sealed
 Greased,
 with relubrication facility



KTN...-C-PP-AS, KTNS...-C-PP-AS

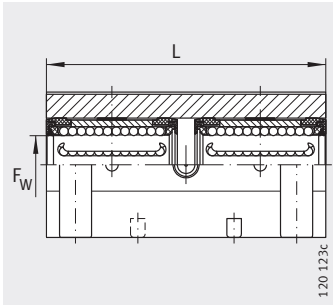


KTN...-C-PP-AS, KTNS...-C-PP-AS

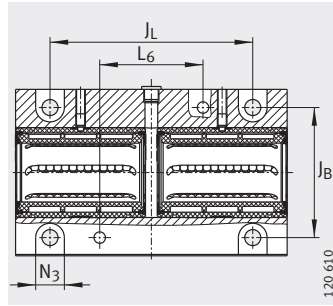
Dimension table - Dimensions in mm

Designation	Mass m ≈g	Dimensions				Mounting dimensions				
		F _W	B	L	H	J _B ±0,15	B ₁	A ₅ ±0,01	J _L ⁴⁾ ±0,15	L ₆ ⁴⁾
KTN12-C-PP-AS	210	12	43	70	35	32	34	21,5	56	24
KTNS12-C-PP-AS										
KTN16-C-PP-AS	350	16	53	78	42	40	40	26,5	64	26
KTNS16-C-PP-AS										
KTN20-C-PP-AS	560	20	60	96	50	45	44	30	76	33
KTNS20-C-PP-AS										
KTN25-C-PP-AS	1 150	25	78	122	60	60	59,5	39	94	44
KTNS25-C-PP-AS										
KTN30-C-PP-AS	1 700	30	87	142	70	68	63	43,5	106	54
KTNS30-C-PP-AS										
KTN40-C-PP-AS	3 200	40	108	166	90	86	76	54	124	62
KTN50-C-PP-AS	5 900	50	132	212	105	108	90	66	160	84

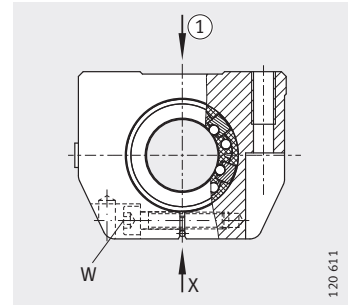
- 1) The basic load ratings are only valid for hardened (670 HV + 170 HV) and ground shaft raceways.
- 2) Basic load rating in main load direction.
- 3) For fixing screws ISO 4 762-8.8.
If there is a possibility of settling, the screws should be secured against rotation.
- 4) Dimensions J_L, L₆ and lubrication hole symmetrical to the bearing length L.
- 5) Lubrication hole closed off using plastic plug. Lubrication nipple, designs and dimensions see page 30.
- 6) Centring for dowel hole.



KTN..-C-PP-AS



KTNS..-C-PP-AS



① Main load direction

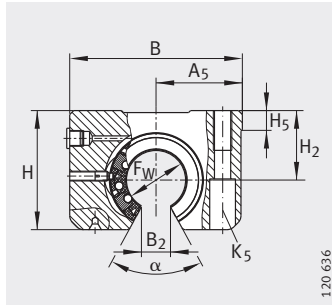


H ₂ +0,008 -0,016	A ₃	H ₅	H ₄	T ₅	H ₆	G ₂	N ₁	N ₄ ⁶⁾	N ₃	K ₅ ³⁾	G ₃ ⁴⁾⁵⁾	Width across flats W	Ball rows Quantity	Basic load ratings ¹⁾²⁾	
														dyn. C N	stat. C ₀ N
18	18	6	25,5	11	16,5	M5	4,3	4	8	M4	M6	- 2,5	5	1 270	1 110
22	22	7	28	13	21	M6	5,3	4	10	M5	M6	- 3	5	1 620	1 500
25	25	7,5	33	18	24	M8	6,6	5	11	M6	M6	- 4	6	2 850	2 480
30	30	8,5	40	22	29	M10	8,4	6	15	M8	M8X1	- 5	6	5 000	4 450
35	35	9,5	44,5	22	34	M10	8,4	6	15	M8	M8X1	- 5	6	6 100	5 800
45	45	11	56	26	44	M12	10,5	8	18	M10	M8X1	-	6	10 300	8 800
50	50	11	60	35	49	M16	13,5	10	20	M12	M8X1	-	6	15 200	13 200

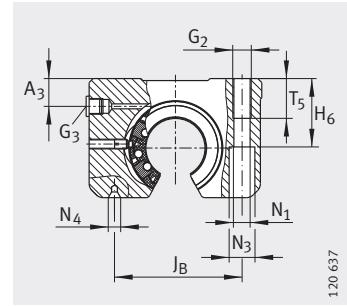
Light range

Linear ball bearing and housing units

With segment cutout
or with slot
Sealed
Greased,
with relubrication facility



KGNO...-C-PP-AS,
KGNOS...-C-PP-AS



KGNO...-C-PP-AS,
KGNOS...-C-PP-AS

Dimension table - Dimensions in mm

Designation	Mass m ≈ g	Dimensions				Mounting dimensions						
		F _w	B	L	H	J _B	A ₅	B ₂ ⁵⁾	J _L ⁴⁾	H ₂ +0,008 -0,016	A ₃	H ₅
KGNO12-C-PP-AS	90	12	43	32	28	32	21,5	6,5	23	18	8	6
KGNOS12-C-PP-AS												
KGNO16-C-PP-AS	150	16	53	37	35	40	26,5	9	26	22	10	7,5
KGNOS16-C-PP-AS												
KGNO20-C-PP-AS	250	20	60	45	42	45	30	9	32	25	11	8
KGNOS20-C-PP-AS												
KGNO25-C-PP-AS	520	25	78	58	51	60	39	11,5	40	30	12,5	9
KGNOS25-C-PP-AS												
KGNO30-C-PP-AS	760	30	87	68	60	68	43,5	14	45	35	14	9,5
KGNOS30-C-PP-AS												
KGNO40-C-PP-AS	1 400	40	108	80	77	86	54	19	58	45	17,5	12
KGNOS40-C-PP-AS												
KGNO50-C-PP-AS	2 400	50	132	100	88	108	66	22,5	50	50	17,5	12
KGNOS50-C-PP-AS												

1) The basic load ratings are only valid for hardened (670 HV + 170 HV) and ground shaft raceways.

2) Basic load rating in main load direction.

3) For fixing screws ISO 4 762-8.8.

If there is a possibility of settling, the screws should be secured against rotation.

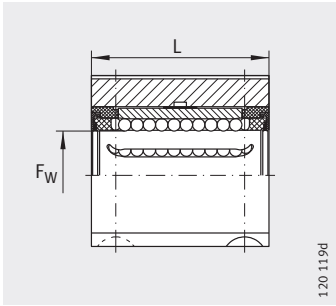
4) Dimensions J_L and lubrication hole symmetrical to bearing length L.

5) Dimension B₂ on diameter F_w.

6) Lubrication hole closed off using plastic plug.

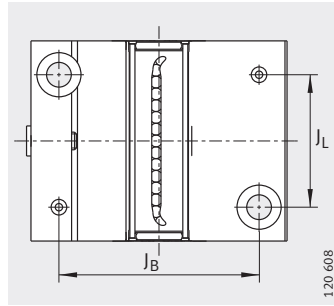
Lubrication nipple see page 30.

7) Centring hole DIN 332 type A.



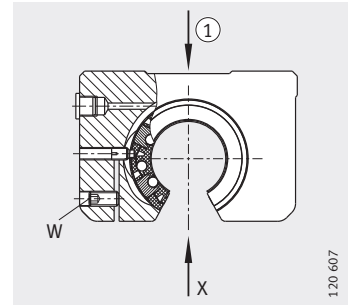
KGNO..-C-PP-AS

120 119d



KGNOS..-C-PP-AS
View X

120 608



① Main load direction

120 607

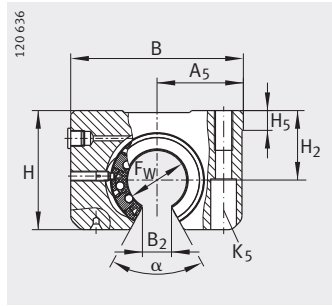


T ₅	H ₆	G ₂	N ₁	N ₄ ⁷⁾	N ₃	K ₅ ³⁾	G ₃ ⁴⁾⁶⁾	Width across flats W	α °	Ball rows Quantity	Basic load ratings ¹⁾²⁾	
											dyn. C N	stat. C ₀ N
11	16,5	M5	4,3	1,6X3,35	8	M4	M6	— 2,5	66	4	840	640
13	21	M6	5,3	1,6X3,35	10	M5	M6	— 2,5	68	4	1 000	750
18	24	M8	6,6	2X4,25	11	M6	M6	— 2,5	55	5	1 740	1 240
22	29	M10	8,4	2,5X5,3	15	M8	M8X1	— 3	57	5	3 100	2 260
22	34	M10	8,4	2,5X5,3	15	M8	M8X1	— 3	57	5	3 750	2 850
26	44	M12	10,5	3,15X6,7	18	M10	M8X1	— 4	56	5	6 300	4 350
35	49	M16	13,5	4X8,5	20	M12	M8X1	— 5	54	5	9 300	6 500

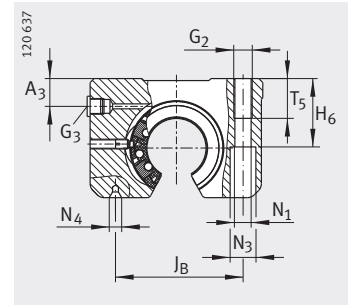
Light range

Linear ball bearing and housing units

- Tandem arrangement
- With segment cutout
- With or without slot
- Sealed
- Greased, with relubrication facility



KTNO...-C-PP-AS,
KTNOS...-C-PP-AS



KTNO...-C-PP-AS,
KTNOS...-C-PP-AS

Dimension table - Dimensions in mm

Designation	Mass m ≈g	Dimensions				Mounting dimensions					
		F _w	B	L	H	J _B	A ₅	B ₂ ⁵⁾	J _L ⁴⁾	L ₆ ⁴⁾	H ₂
KTNO12-C-PP-AS	190	12	43	70	28	32	21,5	6,5	56	24	18
KTNO12-C-PP-AS											
KTNO16-C-PP-AS	310	16	53	78	35	40	26,5	9	64	26	22
KTNO16-C-PP-AS											
KTNO20-C-PP-AS	520	20	60	96	42	45	30	9	76	33	25
KTNO20-C-PP-AS											
KTNO25-C-PP-AS	1 060	25	78	122	51	60	39	11,5	94	44	30
KTNO25-C-PP-AS											
KTNO30-C-PP-AS	1 550	30	87	142	60	68	43,5	14	106	54	35
KTNO30-C-PP-AS											
KTNO40-C-PP-AS	2 900	40	108	166	77	86	54	19	124	62	45
KTNO50-C-PP-AS	5 000	50	132	212	88	108	66	22,5	160	84	50

1) The basic load ratings are only valid for hardened (670 HV + 170 HV) and ground shaft raceways.

2) Basic load rating in main load direction.

3) For fixing screws ISO 4 762-8.8.

If there is a possibility of settling, the screws should be secured against rotation.

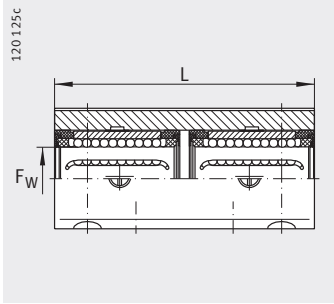
4) Dimensions J_L, L₆ and lubrication hole symmetrical to the bearing length L.

5) Dimension B₂ on diameter F_w.

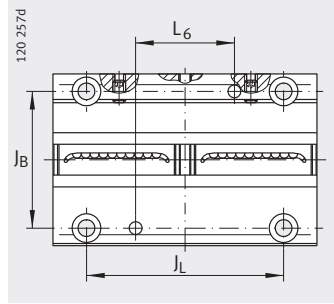
6) Lubrication hole closed off using plastic plug.

Lubrication nipple see page 30.

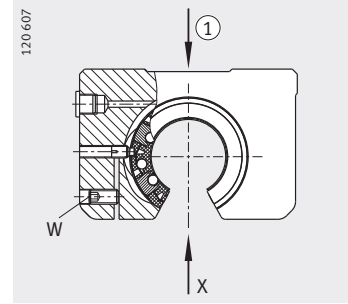
7) Centring hole DIN 332 type A.



KTNOS...-C-PP-AS



KTNOS...-C-PP-AS
View X (rotated 90°)



① Main load direction

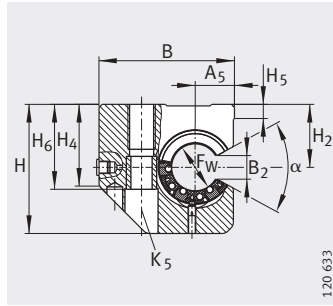


A ₃	H ₅	T ₅	H ₆	G ₂	N ₁	N ₄ ⁷⁾	N ₃	K ₅ ³⁾	G ₃ ⁴⁾⁶⁾	Width across flats W	α °	Ball rows Quantity	Basic load ratings ¹⁾²⁾	
													dyn. C N	stat. C ₀ N
8	6	11	16,5	M5	4,3	1,6X3,35	8	M4	M6	— 2,5	66	4	1 370	1 270
10	7,5	13	21	M6	5,3	1,6X3,35	10	M5	M6	— 2,5	68	4	1 620	1 500
11	8	18	24	M8	6,6	2X4,25	11	M6	M6	— 2,5	55	5	2 850	2 480
12,5	9	22	29	M10	8,4	2,5X5,3	15	M8	M8X1	— 3	57	5	5 100	4 550
14	9,5	22	34	M10	8,4	2,5X5,3	15	M8	M8X1	— 3	57	5	6 100	5 700
17,5	12	26	44	M12	10,5	3,15X6,7	18	M10	M8X1	—	56	5	10 300	8 700
17,5	12	35	49	M16	13,5	4X8,5	20	M12	M8X1	—	54	5	15 000	13 000

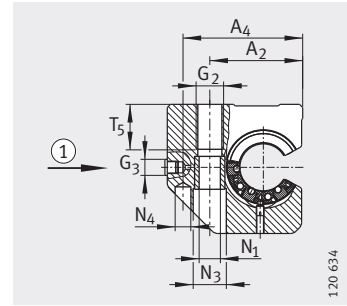
Light range

Linear ball bearing and housing units

Lateral segment cutout
 With or without slot
 Sealed
 Greased,
 with relubrication facility



KGNC...-C-PP-AS,
 KGNC...-C-PP-AS

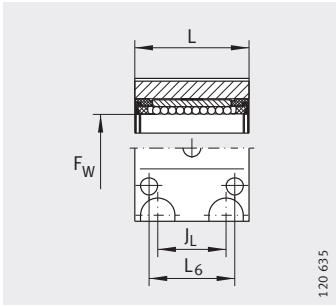


KGNC...-C-PP-AS,
 KGNC...-C-PP-AS
 ① Main load direction

Dimension table - Dimensions in mm

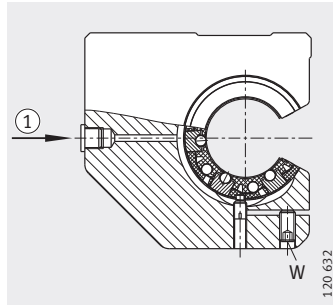
Designation	Mass m ≈g	Dimensions				Mounting dimensions					
		F _w	B	L	H	A ₂	A ₄	A ₅	B ₂ ⁵⁾	J _L ⁴⁾	L ₆ ⁴⁾
KGNC20-C-PP-AS	350	20	60	47	60	39	51	17	9	30	36
KGNC20-C-PP-AS											
KGNC25-C-PP-AS	680	25	75	58	72	49	64	21	11,5	36	45
KGNC25-C-PP-AS											
KGNC30-C-PP-AS	1000	30	86	68	82	59	76	25	14	42	52
KGNC30-C-PP-AS											
KGNC40-C-PP-AS	1800	40	110	80	100	75	97	32	19	48	60
KGNC40-C-PP-AS											
KGNC50-C-PP-AS	2900	50	127	100	115	88	109	38	22,5	62	80
KGNC50-C-PP-AS											

- 1) The basic load ratings are only valid for hardened (670 HV + 170 HV) and ground shaft raceways.
- 2) Basic load rating in main load direction.
- 3) For fixing screws ISO 4762-8.8.
If there is a possibility of settling, the screws should be secured against rotation.
- 4) Dimensions J_L, L₆ and lubrication hole symmetrical to the bearing length L.
- 5) Dimension B₂ on diameter F_w.
- 6) Lubrication hole closed off using plastic plug.
Lubrication nipple see page 30.
- 7) Centring for dowel hole.



120 635

KGNC...-C-PP-AS,
KGNCS...-C-PP-AS



120 632

KGNCS...-C-PP-AS
① Main load direction

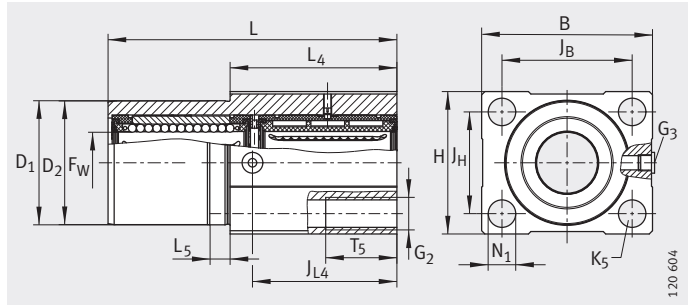


												Ball rows Quantity	Basic load ratings ¹⁾²⁾		
H ₂ +0,008 -0,016	H ₅	H ₄	T ₅	H ₆	G ₂	N ₁	N ₄ ⁷⁾	N ₃	K ₅ ³⁾	G ₃ ⁴⁾⁶⁾	Width across flats W		α °	dyn. C N	stat. C ₀ N
30	8	37,5	18	42	M10	8,4	6	15	M8	M6	- 2,5	55	5	1 740	1 240
35	8	45	22	50	M12	10,5	8	18	M10	M8X1	- 3	57	5	3 100	2 260
40	9	52	29	55	M16	13,5	10	20	M12	M8X1	- 3	57	5	3 750	2 850
45	9	60	36	67	M20	15,5	12	24	M14	M8X1	- 4	56	5	6 300	4 350
50	9	70	36	78	M20	17,5	12	26	M16	M8X1	- 5	54	5	9 300	6 500

Light range

Linear ball bearing and housing units

- Centring collar
- Tandem arrangement
- Sealed
- Greased, with relubrication facility



KTFN..-C-PP-AS

Dimension table - Dimensions in mm

Designation	Mass m ≈g	Dimensions				Mounting dimensions			
		F _w	B	L	H	J _B	L ₄	L ₅	J _{L4}
KTFN12-C-PP-AS	200	12	42	70	34	32	46	10	35
KTFN16-C-PP-AS	300	16	50	78	40	38	50	10	39
KTFN20-C-PP-AS	500	20	60	96	50	45	60	10	48
KTFN25-C-PP-AS	1 000	25	74	122	60	56	73	10	61
KTFN30-C-PP-AS	1 400	30	84	142	70	64	82	10	71

- 1) The basic load ratings are only valid for hardened (670 HV + 170 HV) and ground shaft raceways.
- 2) Recommended locating bore for D₁ = H7.
- 3) Lubrication hole closed off using plastic plug.
Lubrication nipple see page 30.



D ₁ ²⁾	D ₂	j _h	T ₅	G ₂	N ₁	K ₅	G ₃ ³⁾	Ball rows Quantity	Basic load ratings ¹⁾	
									dyn. C N	stat. C ₀ N
g7	-0,1 -0,3	±0,15								
30	29,8	24	13	M6	5,3	M5	M8X1	5	1 270	1 110
35	34,8	28	18	M8	6,6	M6	M8X1	5	1 620	1 500
42	41,8	35	22	M10	8,4	M8	M8X1	6	2 850	2 480
52	51,8	42	26	M12	10,5	M10	M8X1	6	5 000	4 450
61	60,8	50	35	M16	13,5	M12	M8X1	6	6 100	5 800

Heavy duty range

Linear ball bearings

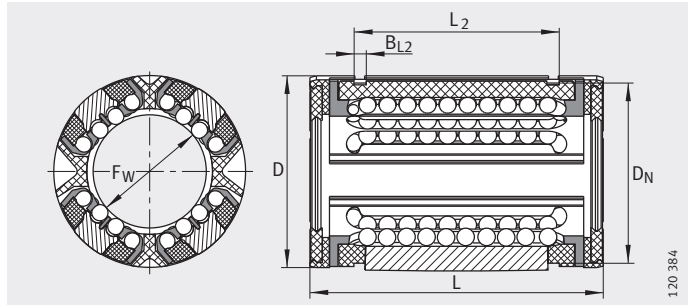
Self-aligning

Closed

or with segment cutout

Unsealed or sealed

Relubrication facility



KS, KS..-PP

Dimension table - Dimensions in mm

Designation				Mass m ≈ g	Dimensions			Mounting dimensions		
6)	7)	6)	7)		F _w	D	L	B ₂ ³⁾	L ₂ H13	B _{L2}
KS12	KS12-PP	-	-	18	12	22	32	-	22,6	1,3
-	-	KSO12	KSO12-PP	13				7,6	-	-
KS16	KS16-PP	-	-	28	16	26	36	-	24,6	1,3
-	-	KSO16	KSO16-PP	19				10,1	-	-
KS20	KS20-PP	-	-	51	20	32	45	-	31,2	1,6
-	-	KSO20	KSO20-PP	38				10	-	-
KS25	KS25-PP	-	-	102	25	40	58	-	43,7	1,85
-	-	KSO25	KSO25-PP	75				12,5	-	-
KS30	KS30-PP	-	-	172	30	47	68	-	51,7	1,85
-	-	KSO30	KSO30-PP	135				14,3	-	-
KS40	KS40-PP	-	-	335	40	62	80	-	60,3	2,15
-	-	KSO40	KSO40-PP	259				18,2	-	-
KS50	KS50-PP	-	-	589	50	75	100	-	77,3	2,65
-	-	KSO50	KSO50-PP	454				22,7	-	-

1) The basic load ratings are only valid for hardened (670 HV + 170 HV) and ground shaft raceways.

2) Basic load rating in main load direction.

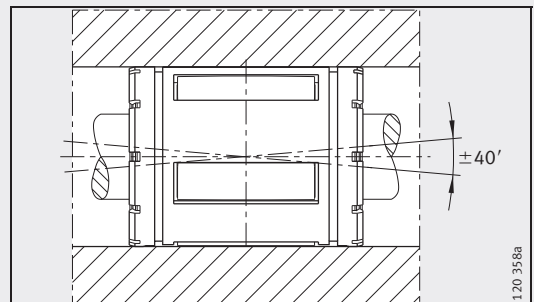
3) Dimension B₂ on diameter F_w.

4) Hole position symmetrical to bearing length L.

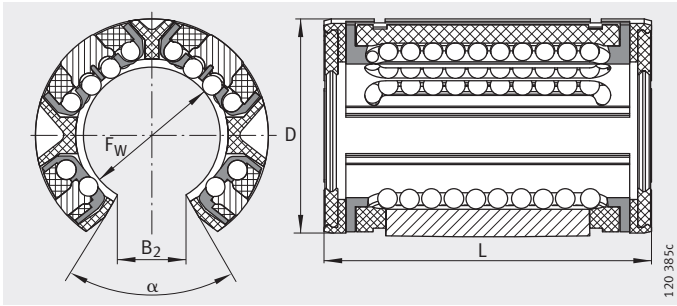
5) Only one lubrication and fixing hole each in size 16 and 20.

6) With preservative, gap seals on both sides.

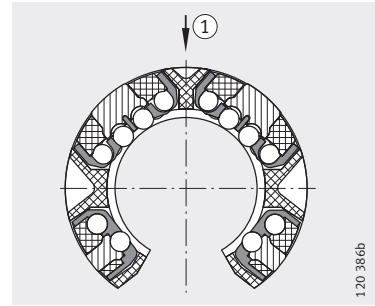
7) With initial greasing, contact seals on both sides.



Self-aligning up to ±40'

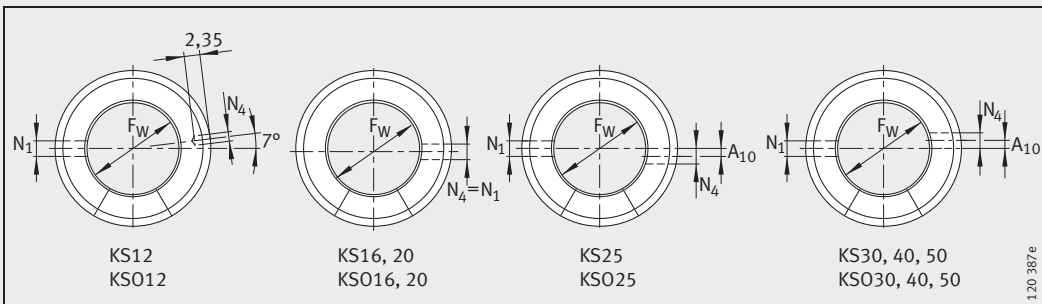


KSO, KSO..-PP



KSO, KSO..-PP
① Main load direction

D _N	A ₁₀	N ₁ ⁴⁾	N ₄ ⁴⁾	α °	Ball rows Quantity	Basic load ratings ¹⁾²⁾			
						dyn. C _{min} N	stat. C _{0 min} N	dyn. C _{max} N	stat. C _{0 max} N
21	-	-	3	-	8	630	600	900	1 100
-				78	6	-	-	900 ²⁾	1 100 ²⁾
25	-	3 ⁵⁾	3 ⁵⁾	-	8	1 060	950	1 430	1 550
-				78	6	-	-	1 430 ²⁾	1 550 ²⁾
30,7	-	3 ⁵⁾	3 ⁵⁾	-	8	1 780	1 600	2 200	2 310
-				60	6	-	-	2 200 ²⁾	2 310 ²⁾
38	1,5	3,5	3	-	8	2 700	2 430	3 950	4 300
-				60	6	-	-	3 950 ²⁾	4 300 ²⁾
44,7	2	3,5	3	-	8	4 650	3 970	5 900	6 000
-				57	6	-	-	5 900 ²⁾	6 000 ²⁾
59,4	1,5	3,5	3	-	8	8 800	7 200	10 200	9 600
-				54	6	-	-	10 200 ²⁾	9 600 ²⁾
71,4	2,5	4,5	5	-	8	12 300	9 700	15 100	13 900
-				54	6	-	-	15 100 ²⁾	13 900 ²⁾



Fixing holes⁵⁾

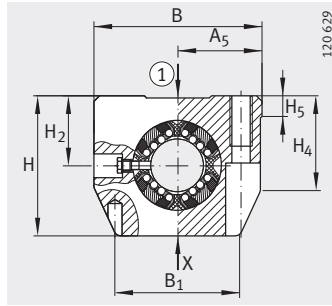
Heavy duty range

Linear ball bearing and housing units

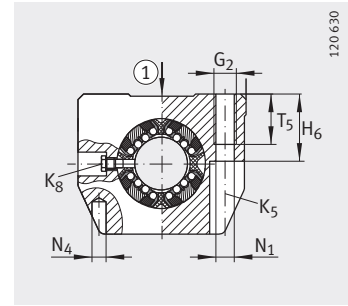
Closed or with slot

Sealed

Greased,
with relubrication facility



KGSNG...-PP-AS, KGSNS...-PP-AS
① Main load direction



KGSNG...-PP-AS, KGSNS...-PP-AS
① Main load direction

Dimension table - Dimensions in mm

Designation		Mass m ≈g	Dimensions				Mounting dimensions			
			F _w	B	L	H	J _B ±0,15		A ₅ ±0,01	J _L ⁴⁾ ±0,15
KGSNG12-PP-AS	-	110	12	43	32	35	32	34	21,5	23
-	KGSNS12-PP-AS	100								
KGSNG16-PP-AS	-	220	16	53	37	42	40	40	26,5	26
-	KGSNS16-PP-AS	200								
KGSNG20-PP-AS	-	370	20	60	45	50	45	44	30	32
-	KGSNS20-PP-AS	360								
KGSNG25-PP-AS	-	630	25	78	58	60	60	59,4	39	40
-	KGSNS25-PP-AS	550								
KGSNG30-PP-AS	-	890	30	87	68	70	68	63	43,5	45
-	KGSNS30-PP-AS	730								
KGSNG40-PP-AS	-	1 300	40	108	80	90	86	76	54	58
-	KGSNS40-PP-AS	1 350								
KGSNG50-PP-AS	-	2 200	50	132	100	105	108	90	66	50
-	KGSNS50-PP-AS	2 250								

1) The basic load ratings are only valid for hardened (670 HV + 170 HV) and ground shaft raceways.

2) Basic load rating in main load direction.

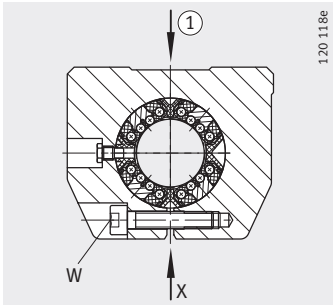
3) For fixing screws ISO 4762-8.8.

If there is a possibility of settling, the screws should be secured against rotation.

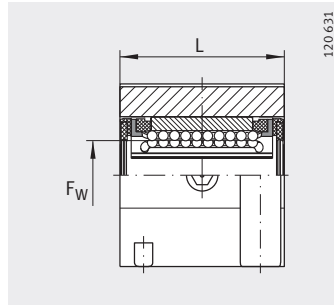
4) Dimension J_L and lubrication hole symmetrical to the bearing length L.

5) Lubrication nipple. Designs and dimensions see page 29.

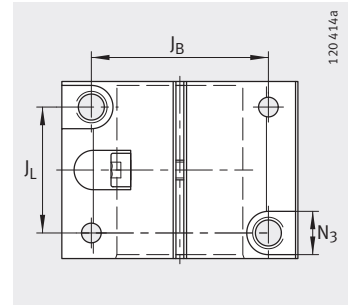
6) Centring for dowel hole.



KGSNS..-PP-AS
 ① Main load direction



KGSNG..-PP-AS, KGSNS..-PP-AS



KGSNS..-PP-AS

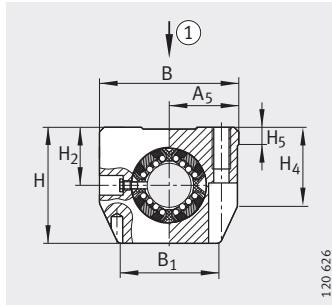


H ₂ +0,008 -0,016	H ₅	H ₄	T ₅	H ₆	G ₂	N ₁	N ₄ ⁽⁶⁾	N ₃	K ₅ ⁽³⁾	K ₈ ⁽⁴⁾⁵⁾	Width across flats W	Ball rows Quantity	Basic load ratings ¹⁾²⁾	
													dyn. C _{max} N	stat. C _{0 max} N
18	5,4	26,6	11	16,5	M5	4,3	4	8	M4	NIP4MZ	— 2,5	8	900	1 100
22	6,9	29,3	13	21	M6	5,3	4	10	M5	NIP4MZ	— 3	8	1 430	1 550
25	7,4	34,1	18	24	M8	6,6	5	11	M6	NIP4MZ	— 4	8	2 200	2 310
30	8,3	41,5	22	29	M10	8,4	6	15	M8	NIP5MZ	— 5	8	3 950	4 300
35	9,3	46,2	22	34	M10	8,4	6	15	M8	NIP5MZ	— 5	8	5 900	6 000
45	11,7	57,6	26	44	M12	10,5	8	18	M10	NIP5MZ	— 6	8	10 200	9 600
50	10,6	62	35	49	M16	13,5	10	20	M12	NIP6MZ	— 8	8	15 100	13 900

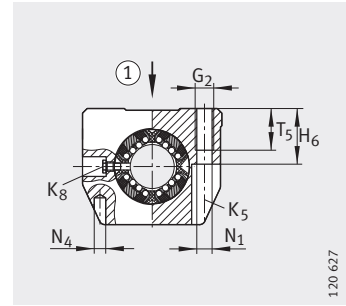
Heavy duty range

Linear ball bearing and housing units

Tandem arrangement
 Closed or with slot
 Sealed
 Greased,
 with relubrication facility



KTSG...PP-AS, KTSS...PP-AS
 ① Main load direction

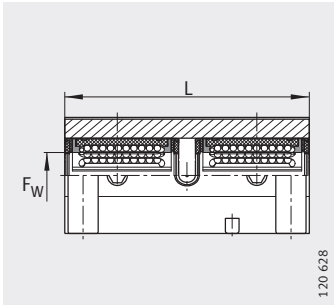


KTSG...PP-AS, KTSS...PP-AS
 ① Main load direction

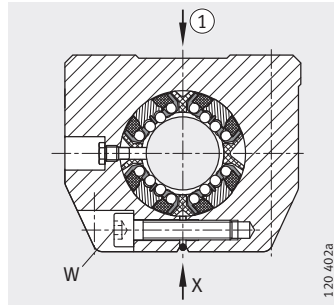
Dimension table - Dimensions in mm

Designation		Mass m ≈g	Dimensions				Mounting dimensions				
			F _W	B	L	H	J _B	B ₁	A ₅	J _L ⁴⁾	L ₆ ⁴⁾
KTSG12-PP-AS	-	210	12	43	70	35	32	34	21,5	56	24
-	KTSS12-PP-AS										
KTSG16-PP-AS	-	380	16	53	78	42	40	40	26,5	64	26
-	KTSS16-PP-AS										
KTSG20-PP-AS	-	550	20	60	96	50	45	44	30	76	33
-	KTSS20-PP-AS										
KTSG25-PP-AS	-	1 130	25	78	122	60	60	59,4	39	94	44
-	KTSS25-PP-AS										
KTSG30-PP-AS	-	1 780	30	87	142	70	68	63	43,5	106	54
-	KTSS30-PP-AS										

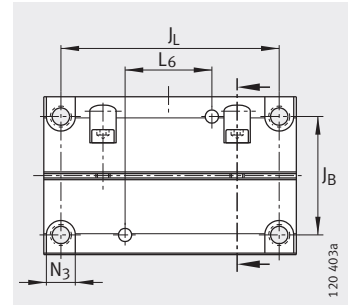
- 1) The basic load ratings are only valid for hardened (670 HV + 170 HV) and ground shaft raceways.
- 2) Basic load rating in main load direction.
- 3) For fixing screws ISO 4 762-8.8.
If there is a possibility of settling, the screws should be secured against rotation.
- 4) Dimensions J_L, L₆ and lubrication hole symmetrical to the bearing length L.
- 5) Lubrication nipple. Designs and dimensions see page 29.
- 6) Centring for dowel hole.



KTSG...PP-AS, KTSS...PP-AS



KTSS...PP-AS
① Main load direction



KTSS...PP-AS

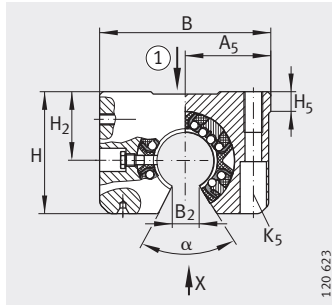


H ₂ +0,008 -0,016	H ₅	H ₄	T ₅	H ₆	G ₂	N ₁	N ₄ ⁶⁾	N ₃	K ₅ ³⁾	K ₈ ⁴⁾⁵⁾	Width across flats W	Ball rows	Basic load ratings ¹⁾²⁾	
												Quantity	dyn. C _{max} N	stat. C _{0 max} N
18	5,4	26,6	11	16,5	M5	4,3	4	8	M4	NIP4MZ	— 2,5	8	1 460	2 100
22	6,9	29,3	13	21	M6	5,3	4	10	M5	NIP4MZ	— 3	8	2 330	3 100
25	7,4	34,1	18	24	M8	6,6	5	11	M6	NIP4MZ	— 4	8	3 500	4 600
30	8,3	41,5	22	29	M10	8,4	6	15	M8	NIP5MZ	— 5	8	6 400	8 600
35	9,3	46,2	22	34	M10	8,4	6	15	M8	NIP5MZ	— 5	8	9 600	12 000

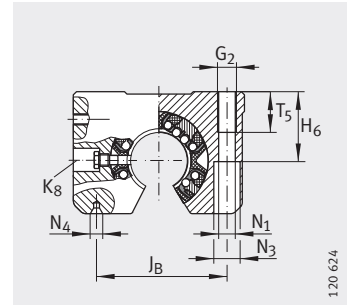
Heavy duty range

Linear ball bearing and housing units

With segment cutout
 With or without slot
 Sealed
 Greased,
 with relubrication facility



KGSNO...-PP-AS, KGSNOS...-PP-AS
 ① Main load direction

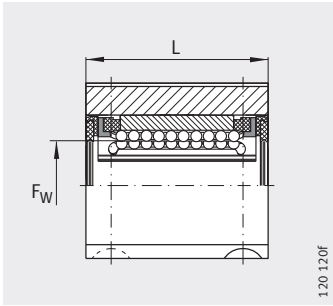


KGSNO...-PP-AS, KGSNOS...-PP-AS

Dimension table - Dimensions in mm

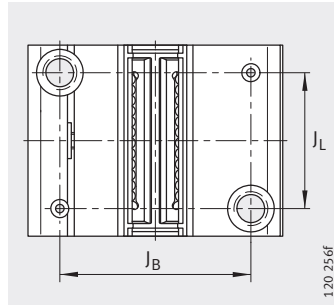
Designation		Mass m ≈ g	Dimensions				Mounting dimensions			
			F _W	B	L	H	J _B	A ₅	B ₂ ⁵⁾	J _L ⁴⁾
KGSNO12-PP-AS	–	80	12	43	32	28	32	21,5	7,6	23
–	KGSNOS12-PP-AS	90								
KGSNO16-PP-AS	–	150	16	53	37	35	40	26,5	10,1	26
–	KGSNOS16-PP-AS	150								
KGSNO20-PP-AS	–	200	20	60	45	42	45	30	10	32
–	KGSNOS20-PP-AS	250								
KGSNO25-PP-AS	–	410	25	78	58	51	60	39	12,5	40
–	KGSNOS25-PP-AS	520								
KGSNO30-PP-AS	–	600	30	87	68	60	68	43,5	14,3	45
–	KGSNOS30-PP-AS	760								
KGSNO40-PP-AS	–	1 100	40	108	80	77	86	54	18,2	58
–	KGSNOS40-PP-AS	1 400								
KGSNO50-PP-AS	–	2 870	50	132	100	88	108	66	22,7	50
–	KGSNOS50-PP-AS	2 670								

- 1) The basic load ratings are only valid for hardened (670 HV + 170 HV) and ground shaft raceways.
- 2) Basic load rating in main load direction.
- 3) For fixing screws ISO 4 762-8.8.
If there is a possibility of settling, the screws should be secured against rotation.
- 4) Dimension J_L and lubrication hole symmetrical to the bearing length L.
- 5) Dimension B₂ on diameter F_W.
- 6) Lubrication nipple. Designs and dimensions see page 29.
- 7) Centring hole DIN 332 type A.



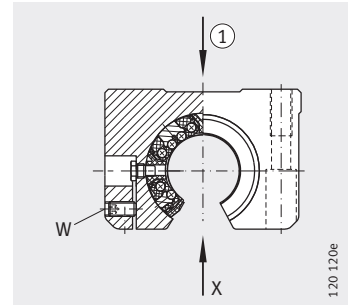
KGSNO..-PP-AS, KGSNOS..-PP-AS

120 120f



KGSNOS..-PP-AS
View X

120 256f



KGSNOS..-PP-AS
① Main load direction

120 120e

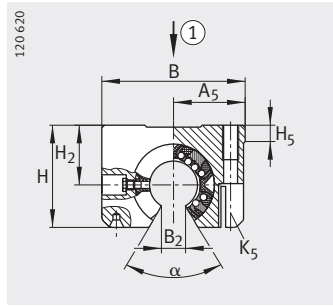


H ₂ +0,008 -0,016	H ₅	T ₅	H ₆	G ₂	N ₁	N ₄ ⁷⁾	N ₃	K ₅ ³⁾	K ₈ ⁴⁾⁶⁾	Width across flats W	α °	Ball rows Quantity	Basic load ratings ¹⁾²⁾	
													dyn. C _{max} N	stat. C _{0 max} N
18	6,1	11	16,5	M5	4,3	1,6X3,35	8	M4	NIP4MZ	— 2,5	78	6	900	1 100
22	7,5	13	21	M6	5,3	1,6X3,35	10	M5	NIP4MZ	— 2,5	68	6	1 430	1 550
25	8	18	24	M8	6,6	2X4,25	11	M6	NIP4MZ	— 2,5	55	6	2 200	2 310
30	8,8	22	29	M10	8,4	2,5X5,3	15	M8	NIP5MZ	— 3	57	6	3 950	4 300
35	9,7	22	34	M10	8,4	2,5X5,3	15	M8	NIP5MZ	— 3	57	6	5 900	6 000
45	12,4	26	44	M12	10,5	3,15X6,7	18	M10	NIP5MZ	— 4	56	6	10 200	9 600
50	11,1	35	49	M16	13,5	4X8,5	20	M12	NIP5MZ	— 5	54	6	15 100	13 900

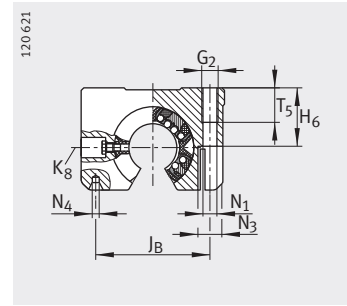
Heavy duty range

Linear ball bearing and housing units

- Tandem arrangement
- With segment cutout
- With or without slot
- Sealed
- Greased, with relubrication facility



KTSO...-PP-AS, KTSOS...-PP-AS
 ① Main load direction



KTSO...-PP-AS, KTSOS...-PP-AS

Dimension table - Dimensions in mm

Designation		Mass	Dimensions				Mounting dimensions			
			F _W	B	L	H	J _B	A ₅	B ₂ ⁵⁾	J _L ⁴⁾
		m								
		≈g					±0,15	±0,01		±0,15
KTSO12-PP-AS	–	190	12	43	70	28	32	21,5	7,6	56
–	KTSOS12-PP-AS									
KTSO16-PP-AS	–	320	16	53	78	35	40	26,5	10,1	64
–	KTSOS16-PP-AS									
KTSO20-PP-AS	–	520	20	60	96	42	45	30	10	76
–	KTSOS20-PP-AS									
KTSO25-PP-AS	–	1 060	25	78	122	51	60	39	12,5	94
–	KTSOS25-PP-AS									
KTSO30-PP-AS	–	1 550	30	87	142	60	68	43,5	14,3	106
–	KTSOS30-PP-AS									

1) The basic load ratings are only valid for hardened (670 HV + 170 HV) and ground shaft raceways.

2) Basic load rating in main load direction.

3) For fixing screws ISO 4 762-8.8.

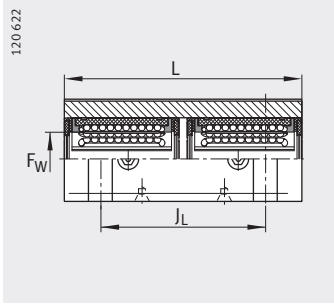
If there is a possibility of settling, the screws should be secured against rotation.

4) Dimensions J_L, L₆ and lubrication hole symmetrical to the bearing length L.

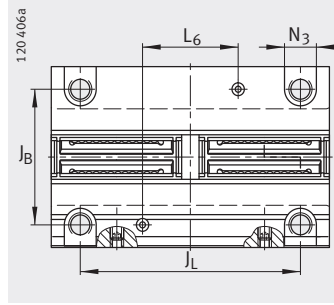
5) Dimension B₂ on diameter F_W.

6) Lubrication nipple. Designs and dimensions see page 29.

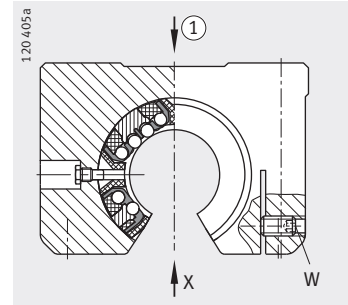
7) Centring hole DIN 332 type A.



KTSO...-PP-AS, KTSOS...-PP-AS



KTSOS...-PP-AS
View X



KTSOS...-PP-AS
① Main load direction

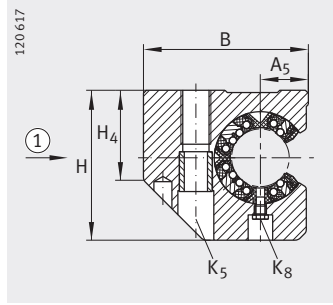


L ₆ ⁴⁾	H ₂ +0,008 -0,016	H ₅	T ₅	H ₆	G ₂	N ₁	N ₄ ⁷⁾	N ₃	K ₅ ³⁾	K ₈ ⁴⁾⁶⁾	Width across flats W	α °	Ball rows Quantity	Basic load ratings ¹⁾²⁾	
														dyn. C _{max} N	stat. C _{0 max} N
24	18	6,1	11	16,5	M5	4,3	1,6X3,35	8	M4	NIP4MZ	— 2,5	66	6	1 460	2 100
26	22	7,5	13	21	M6	5,3	1,6X3,35	10	M5	NIP4MZ	— 2,5	68	6	2 330	3 100
33	25	8	18	24	M8	6,6	2X4,25	11	M6	NIP4MZ	— 2,5	55	6	3 500	4 600
44	30	8,8	22	29	M10	8,4	2,5X5,3	15	M8	NIP5MZ	— 3	57	6	6 400	8 600
54	35	9,7	22	34	M10	8,4	2,5X5,3	15	M8	NIP5MZ	— 3	57	6	9 600	12 000

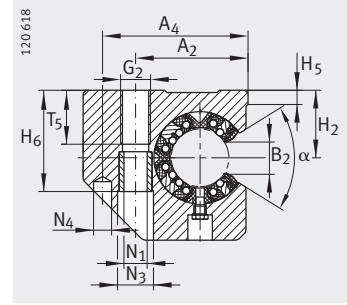
Heavy duty range

Linear ball bearing and housing units

Lateral segment cutout
 With or without slot
 Sealed
 Greased,
 with relubrication facility



KGSC...-PP-AS, KGSCS...-PP-AS
 ① Main load direction

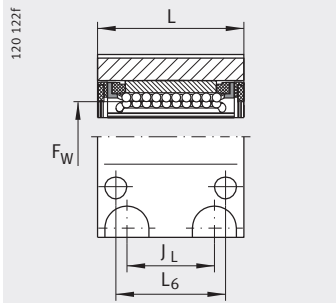


KGSC...-PP-AS, KGSCS...-PP-AS

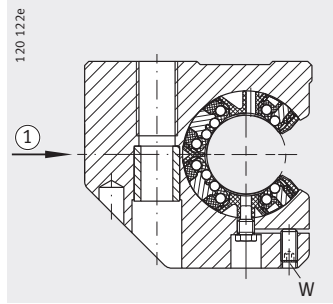
Dimension table - Dimensions in mm

Designation		Mass	Dimensions				Mounting dimensions						
			F _W	B	L	H	A ₂	A ₄	A ₅	B ₂ ⁵⁾	J _L ⁴⁾	L ₆ ⁴⁾	
		m											
		≈g					±0,15			±0,01		±0,15	
KGSC20-PP-AS	–	350	20	60	47	60	39	51	17	10	30	36	
–	KGSCS20-PP-AS												
KGSC25-PP-AS	–	680	25	75	58	72	49	64	21	12,5	36	45	
–	KGSCS25-PP-AS												
KGSC30-PP-AS	–	1 000	30	86	68	82	59	76	25	14,3	42	52	
–	KGSCS30-PP-AS												
KGSC40-PP-AS	–	1 800	40	110	80	100	75	97	32	18,2	48	60	
–	KGSCS40-PP-AS												
KGSC50-PP-AS	–	2 900	50	127	100	115	88	109	38	22,7	62	80	
–	KGSCS50-PP-AS												

- 1) The basic load ratings are only valid for hardened (670 HV + 170 HV) and ground shaft raceways.
- 2) Basic load rating in main load direction.
- 3) For fixing screws ISO 4 762-8.8.
If there is a possibility of settling, the screws should be secured against rotation.
- 4) Dimensions J_L, L₆ and lubrication hole symmetrical to the bearing length L.
- 5) Dimension B₂ on diameter F_W.
- 6) Lubrication nipple. Designs and dimensions see page 29.
- 7) Centring for dowel hole.



KGSC...-PP-AS, KGSCS...-PP-AS



KGSCS...-PP-AS
① Main load direction

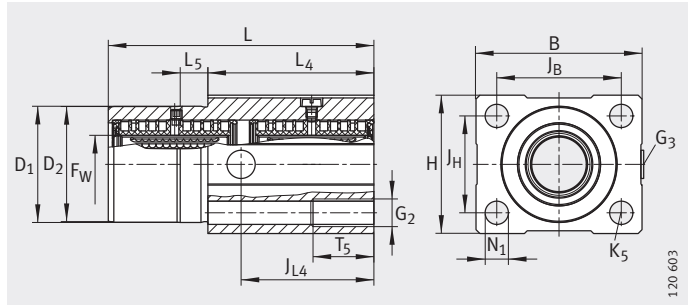


													Ball rows	Basic load ratings ¹⁾²⁾	
H ₂	H ₅	H ₄	T ₅	H ₆	G ₂	N ₁	N ₄ ⁷⁾	N ₃	K ₅ ³⁾	K ₈ ⁴⁾⁶⁾	Width across flats W	α		Quantity	dyn. C _{max} N
30 +0,008 -0,016	8,3	37,5	18	42,6	M10	8,4	6	15	M8	NIP4MZ	— 2,5	55	6		2 200
35	8,2	45	22	50,6	M12	10,5	8	18	M10	NIP5MZ	— 3	57	6	3 950	4 300
40	9	52	29	55,6	M16	13,5	10	20	M12	NIP5MZ	— 3	57	6	5 900	6 000
45	9,5	60	36	67,6	M20	15,5	12	24	M14	NIP5MZ	— 4	56	6	10 200	9 600
50	8,6	70	36	78,8	M20	17,5	12	26	M16	NIP6MZ	— 5	54	6	15 100	13 900

Heavy duty range

Linear ball bearing and housing units

- Centring collar
- Tandem arrangement
- Sealed
- Greased, with relubrication facility



KTFS...PP-AS

Dimension table - Dimensions in mm

Designation	Mass m ≈g	Dimensions				Mounting dimensions		
		F _W	B	L	H	J _B	L ₄	L ₅
KTFS12-PP-AS	180	12	42	70	34	32	40	10
KTFS16-PP-AS	260	16	50	78	40	38	50	10
KTFS20-PP-AS	550	20	60	96	50	45	60	10
KTFS25-PP-AS	700	25	74	122	60	56	73	10
KTFS30-PP-AS	1 100	30	84	142	70	64	82	10

¹⁾ The basic load ratings are only valid for hardened (670 HV + 170 HV) and ground shaft raceways.

²⁾ Recommended locating bore for D₁ = H7.

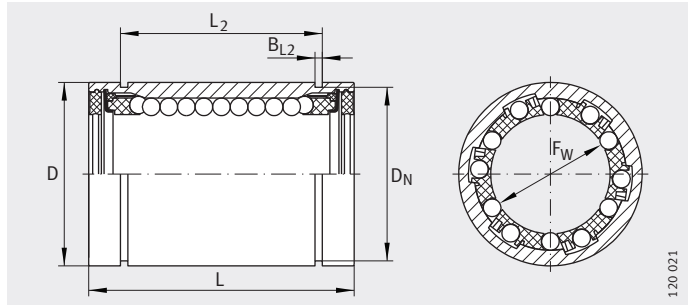


l _{L4}	D ₁ ²⁾ g7	D ₂ -0,1 -0,3	j _h ±0,15	T ₅	G ₂	N ₁	K ₅	G ₃	Ball rows Quantity	Basic load ratings ¹⁾	
										dyn. C _{min} N	stat. C _{0 min} N
35	30	30	24	13	M6	5,3	M5	M8X1	8	1 020	1 200
39	35	35	28	18	M8	6,6	M6	M8X1	8	1 790	1 900
48	42	42	35	22	M10	8,4	M8	M8X1	8	3 100	3 200
61	52	52	42	26	M12	10,5	M10	M8X1	8	4 400	4 850
71	61	61	50	35	M16	13,5	M12	M8X1	8	7 550	7 900

Machined range

Linear ball bearings

Closed, slotted
or with segment cutout
Unsealed or sealed
Not greased, greased,
with relubrication facility



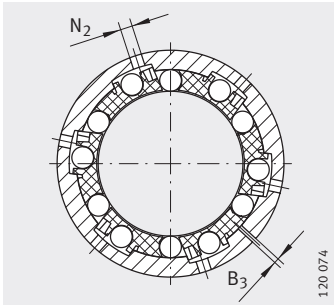
KB

120 021

Dimension table - Dimensions in mm

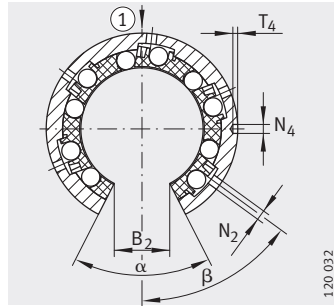
Designation			Mass m ≈g	Dimensions			Mounting dimensions			
7)	8)	9)		F _w	D ⁶⁾	L	B ₂ ³⁾	L ₂	B _{L2} ⁵⁾	
				Tolerances ⁶⁾	h5	h12		H13		
KB12	KB12-PP	KB12-PP-AS	40	12	+0,008 0	22	32	-	22,6	1,3
KBS12	KBS12-PP	KBS12-PP-AS						7,7		
KBO12	KBO12-PP	KBO12-PP-AS						30		
KB16	KB16-PP	KB16-PP-AS	50	16	+0,009 -0,001	26	36	-	24,6	1,3
KBS16	KBS16-PP	KBS16-PP-AS						10,1		
KBO16	KBO16-PP	KBO16-PP-AS						40		
KB20	KB20-PP	KB20-PP-AS	90	20	+0,009 -0,001	32	45	-	31,2	1,6
KBS20	KBS20-PP	KBS20-PP-AS						10		
KBO20	KBO20-PP	KBO20-PP-AS						70		
KB25	KB25-PP	KB25-PP-AS	190	25	+0,011 -0,001	40	58	-	43,7	1,85
KBS25	KBS25-PP	KBS25-PP-AS						12,5		
KBO25	KBO25-PP	KBO25-PP-AS						150		
KB30	KB30-PP	KB30-PP-AS	300	30	+0,011 -0,001	47	68	-	51,7	1,85
KBS30	KBS30-PP	KBS30-PP-AS						13,6		
KBO30	KBO30-PP	KBO30-PP-AS						240		
KB40	KB40-PP	KB40-PP-AS	600	40	+0,013 -0,002	62	80	-	60,3	2,15
KBS40	KBS40-PP	KBS40-PP-AS						18,2		
KBO40	KBO40-PP	KBO40-PP-AS						520		
KB50	KB50-PP	KB50-PP-AS	1 000	50	+0,013 -0,002	75	100	-	77,3	2,65
KBS50	KBS50-PP	KBS50-PP-AS						22,7		
KBO50	KBO50-PP	KBO50-PP-AS						850		

- 1) The basic load ratings are only valid for hardened (670 HV + 170 HV) and ground shaft raceways.
- 2) Basic load rating in main load direction.
- 3) Dimension B₂ on diameter F_w.
- 4) Hole position symmetrical to bearing length L.
- 5) Slot dimensions suitable for retaining rings to DIN 471.
- 6) The tolerances are only valid for KB.
- 7) With preservative.
- 8) With initial greasing, sealed on both sides.
- 9) With initial greasing, sealed on both sides, with relubrication facility.



KBS..-PP-AS

120 074



KBO..-PP-AS

① Main load direction

120 032

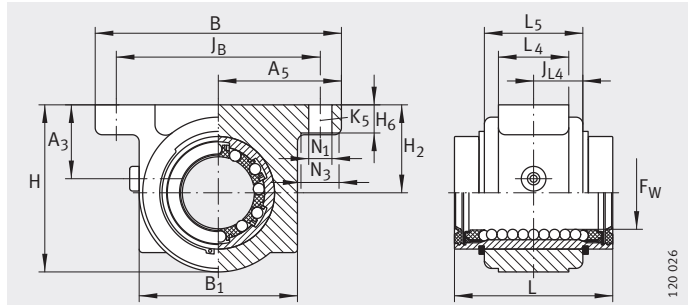


B ₃	D _N ⁵⁾	T ₄	N ₄ ⁴⁾	N ₂	α °	β °	Ball rows Quantity	Basic load ratings ¹⁾²⁾			
								dyn. C _{min} N	stat. C _{0 min} N	dyn. C _{max} N	stat. C _{0 max} N
–	21	–	–	1,5	–	–	5	540	385	640	570
1		1,2	2,2		78	64	4	–	–	600 ²⁾	445 ²⁾
–	24,9	–	–	2	–	–	5	710	530	840	780
1		1,2	2,2		78	64	4	–	–	800 ²⁾	620 ²⁾
–	30,3	–	–	2	–	–	6	1570	1230	1660	1570
1		1,2	2,2		60	52	5	–	–	1600 ²⁾	1280 ²⁾
–	37,5	–	–	2,5	–	–	6	2800	2220	2950	2850
1		1,5	3		60	53	5	–	–	2850 ²⁾	2300 ²⁾
–	44,5	–	–	2,5	–	–	6	3600	2850	3800	3600
1		1,5	3		54	55	5	–	–	3700 ²⁾	3000 ²⁾
–	59	–	–	3	–	–	6	6000	4400	6400	5600
1		1,5	3		54	54	5	–	–	6100 ²⁾	4600 ²⁾
–	72	–	–	4	–	–	6	8700	6300	9200	8000
1		1,5	3		54	54	5	–	–	8900 ²⁾	6600 ²⁾

Machined range

Linear ball bearing and housing units

Closed, slotted
or with segment cutout
Sealed
Greased,
with relubrication facility



KGB..-PP-AS

Dimension table - Dimensions in mm

Designation			Mass m ≈g	Dimensions				Mounting dimensions				
				F _W	B	L	H	J _B	B ₁	A ₅	B ₂ ³⁾	
				Tolerances ⁶⁾		h12						
KGB12-PP-AS	-	-	100	12	+0,008 0	52	32	35,8	42 ± 0,15	31,6	26 ± 0,02	-
-	KGBS12-PP-AS	-						32				7,7
-	-	KGBO12-PP-AS	90									
KGB16-PP-AS	-	-	140	16	+0,009 -0,001	56	36	37,5	46 ± 0,15	35	28 ± 0,02	-
-	KGBS16-PP-AS	-						33,5				10,1
-	-	KGBO16-PP-AS	120									
KGB20-PP-AS	-	-	300	20	+0,009 -0,001	70	45	47,5	58 ± 0,15	45	35 ± 0,02	-
-	KGBS20-PP-AS	-						45				10
-	-	KGBO20-PP-AS	250									
KGB25-PP-AS	-	-	580	25	+0,011 -0,001	80	58	57,5	68 ± 0,15	55	40 ± 0,02	-
-	KGBS25-PP-AS	-						54,5				12,5
-	-	KGBO25-PP-AS	490									
KGB30-PP-AS	-	-	900	30	+0,011 -0,001	88	68	66,5	76 ± 0,2	63	44 ± 0,02	-
-	KGBS30-PP-AS	-						63,5				13,6
-	-	KGBO30-PP-AS	780									
KGB40-PP-AS	-	-	1 430	40	+0,013 -0,002	108	80	83,5	94 ± 0,2	77	54 ± 0,02	-
-	KGBS40-PP-AS	-						79,5				18,2
-	-	KGBO40-PP-AS	1 280									
KGB50-PP-AS	-	-	2 780	50	+0,013 -0,002	135	100	98	116 ± 0,2	96	67,5 ± 0,02	-
-	KGBS50-PP-AS	-						93				22,7
-	-	KGBO50-PP-AS	2 460									

1) The basic load ratings are only valid for hardened (670 HV + 170 HV) and ground shaft raceways.

2) Basic load rating in main load direction.

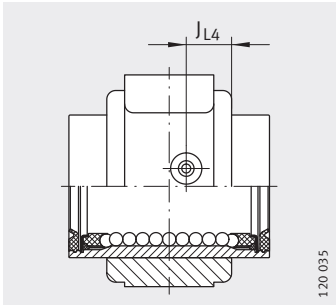
3) Dimension B₂ on diameter F_W.

4) For fixing screws ISO 4 762-8.8.

If there is a possibility of settling, the screws should be secured against rotation.

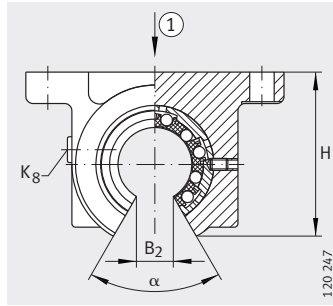
5) Designs and dimensions see page 31.

6) The tolerances are valid for KGB..-PP-AS.



KGBO..-PP-AS

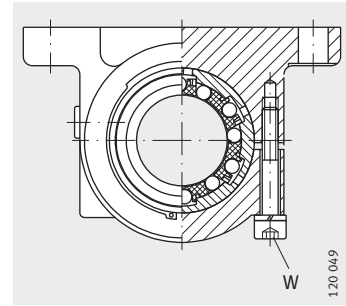
120 035



KGBO, KGBO..-PP-AS

① Main load direction

120 247



KGBS..-PP-AS

120 049

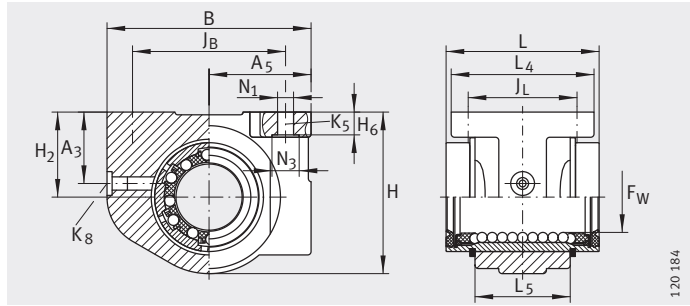


L ₅	L ₄	J L ₄	H ₂ ±0,015	A ₃	H ₆	N ₁	N ₃	K ₅ ⁴⁾	α °	Width across flats W	K ₈	Lubrication nipple ⁵⁾	Ball rows Quantity	Basic load ratings ¹⁾²⁾	
														dyn. C N	stat. C ₀ N
20	12	10	20	15	6	5,5	10	M5	-	2	NIPA1	5	540	385	
		6,5								78					4
22	15	11	20	15	6	5,5	10	M5	-	2	NIPA1	5	710	530	
		6,5								78					4
28	20	14	25	21	8	6,6	11	M6	-	3	NIPA1	6	1 570	1 230	
		9,5								60					5
40	28	20	30	23	10	6,6	11	M6	-	3	NIPA1	6	2 800	2 220	
		15								60					5
48	32	24	35	25	10	6,6	11	M6	-	4	NIPA2	6	3 600	2 850	
		19								54					5
56	40	28	45	30	12	9	15	M8	-	4	NIPA2	6	6 000	4 400	
		23								54					5
72	52	36	50	34	14	11	18	M10	-	5	NIPA2	6	8 700	6 300	
		28								54					5

Machined range

Linear ball bearing and housing units

Closed, slotted
or with segment cutout
Sealed
Greased,
with relubrication facility



KGBA..-PP-AS

Dimension table - Dimensions in mm

Designation			Mass m ≈g	Dimensions			Mounting dimensions					
				F _W	B	L	H	J _B	A ₅	B ₂ ³⁾	L ₄	
				Tolerances ⁶⁾		h12						
KGBA12-PP-AS	-	-	80	12	+0,008 0	42	32	34	32 ±0,15	21 ±0,01	-	32
-	KGBAS12-PP-AS	-						30,5			7,7	
-	-	KGBAO12-PP-AS						70				
KGBA16-PP-AS	-	-	120	16	+0,009 -0,001	50	36	41	40 ±0,15	25 ±0,01	-	35
-	KGBAS16-PP-AS	-						37			10,1	
-	-	KGBAO16-PP-AS						100				
KGBA20-PP-AS	-	-	200	20	+0,009 -0,001	60	45	47,5	45 ±0,15	30 ±0,01	-	42
-	KGBAS20-PP-AS	-						44,5			10	
-	-	KGBAO20-PP-AS						170				
KGBA25-PP-AS	-	-	410	25	+0,011 -0,001	74	58	60	60 ±0,2	37 ±0,01	-	54
-	KGBAS25-PP-AS	-						56			12,5	
-	-	KGBAO25-PP-AS						350				
KGBA30-PP-AS	-	-	610	30	+0,011 -0,001	84	68	67	68 ±0,2	42 ±0,01	-	60
-	KGBAS30-PP-AS	-						63,5			13,6	
-	-	KGBAO30-PP-AS						530				
KGBA40-PP-AS	-	-	1 200	40	+0,013 -0,002	108	80	87	86 ±0,2	54 ±0,015	-	78
-	KGBAS40-PP-AS	-						82,5			18,2	
-	-	KGBAO40-PP-AS						1 070				
KGBA50-PP-AS	-	-	1 880	50	+0,013 -0,002	130	100	98	108 ±0,2	65 ±0,015	-	70
-	KGBAS50-PP-AS	-						93			22,7	
-	-	KGBAO50-PP-AS						1 650				

1) The basic load ratings are only valid for hardened (670 HV + 170 HV) and ground shaft raceways.

2) Basic load rating in main load direction.

3) Dimension B₂ on diameter F_W.

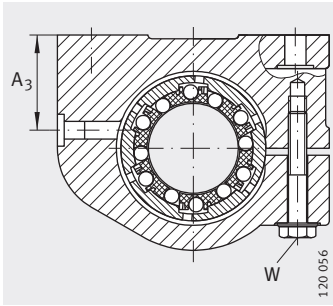
4) For fixing screws ISO 4 762-8.8.

If there is a possibility of settling, the screws should be secured against rotation.

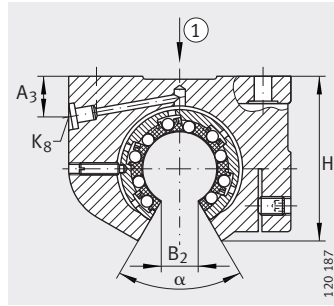
5) Designs and dimensions see page 31.

6) The tolerances are valid for KGBA..-PP-AS.

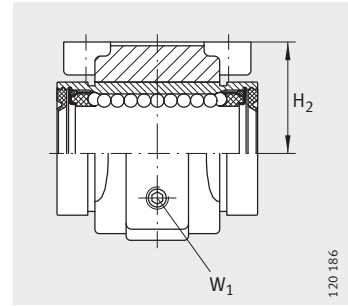
7) Note maximum tightening torques.



KGBAS..-PP-AS



KGBAO..-PP-AS
① Main load direction



KGBAO..-PP-AS

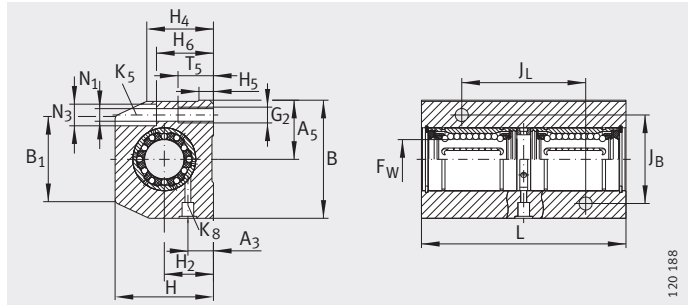


J _L	L ₅	H ₂	A ₃	H ₆	N ₁	N ₃	K ₅ ⁴⁾	α	Width across flats			K ₈	Ball rows Quantity	Basic load ratings ¹⁾²⁾	
									W	W ₁ ⁷⁾				dyn. C	stat. C ₀
											max. Nm				
23±0,15	20	18±0,01	15	4,8	4,7	8	M4	-	-	-	-	NIPA1	5	540	385
			7,8						78	-	2				
26±0,15	22	22±0,01	15	5,4	4,7	8	M4	-	-	-	-	NIPA1	5	710	530
			10						78	-	2,5				
32±0,15	28	25±0,01	21	6,7	4,7	8	M4	-	-	-	-	NIPA1	6	1 570	1 230
			11						60	-	2,5				
40±0,2	40	30±0,01	23	7,8	5,7	10	M5	-	-	-	-	NIPA1	6	2 800	2 220
			13						60	-	3				
45±0,2	48	35±0,01	25	8,7	6,8	11	M6	-	-	-	-	NIPA2	6	3 600	2 850
			14						54	-	3				
58±0,2	56	45±0,01	30	11	9,2	15	M8	-	-	-	-	NIPA2	6	6 000	4 400
			18						54	-	4				
50±0,2	72	50±0,015	34	12,5	9,2	15	M8	-	-	-	-	NIPA2	6	8 700	6 300
			19						54	-	4				

Machined range

Linear ball bearing and housing units

Tandem arrangement
 Closed
 or with segment cutout
 Sealed
 Greased,
 with relubrication facility



KTB...PP-AS

Dimension table - Dimensions in mm

Designation		Mass m ≈g	Dimensions				Mounting dimensions						
			F _W	B	L	H	J _B	A ₅	B ₁	B ₂ ³⁾	J _L ⁵⁾	H ₂	
KTB12-PP-AS	-	310	12	+0,008 0	43	76	35	30	21,5	34	-	40	18
-	KTBO12-PP-AS	260											
KTB16-PP-AS	-	460	16	+0,009 -0,001	53	84	42	36	26,5	40	-	45	22
-	KTBO16-PP-AS	360											
KTB20-PP-AS	-	800	20	+0,009 -0,001	60	104	50	45	30	44	-	55	25
-	KTBO20-PP-AS	620											
KTB25-PP-AS	-	1 490	25	+0,011 -0,001	78	130	60	54	39	60	-	70	30
-	KTBO25-PP-AS	1 180											
KTB30-PP-AS	-	2 300	30	+0,011 -0,001	87	152	70	62	43,5	63	-	85	35
-	KTBO30-PP-AS	1 840											
KTB40-PP-AS	-	3 700	40	+0,013 -0,002	108	176	90	80	54	76	-	100	45
-	KTBO40-PP-AS	3 000											
KTB50-PP-AS	-	6 600	50	+0,013 -0,002	132	224	105	100	66	90	-	125	50
-	KTBO50-PP-AS	5 100											

1) The basic load ratings are only valid for hardened (670 HV + 170 HV) and ground shaft raceways and where the two linear ball bearings are subjected to equal loading.

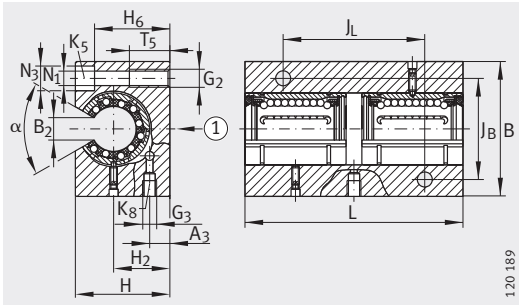
2) Basic load rating in main load direction.

3) Dimension B₂ on diameter F_W.

4) The tolerances are valid for KTB...PP-AS.

5) Dimension J_L and lubrication hole symmetrical to the bearing length L.

6) Lubrication nipple. Designs and dimensions see page 31.



120 189

KTBO..-PP-AS

① Main load direction



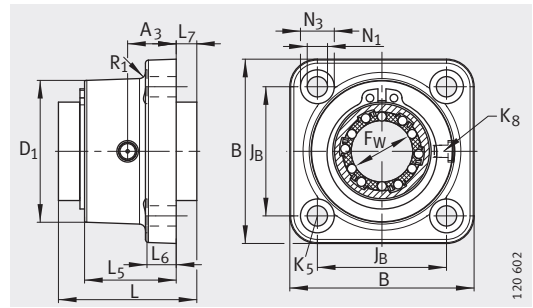
											Fixing screws		Basic load ratings ¹⁾²⁾	
H ₄	A ₃	H ₅	T ₅	H ₆	N ₁	N ₃	G ₂	G ₃	K ₈ ⁶⁾	α	K ₅		dyn. C N	stat. C ₀ N
											ISO 4762	DIN 6912		
25,5	10	5,4	13	28	5,1	10	M6	M6	NIPA1	-	M5	-	880	770
-	6	-		25							78	M5	980 ²⁾	890 ²⁾
20	12	6,9	13	35	5,3	10	M6	M6	NIPA2	-	M5	-	1 150	1 060
-	8	-		29,5							78	M5	1 290 ²⁾	1 240 ²⁾
33	13	7,4	18	37	6,4	11	M8	M6	NIPA2	-	M6	-	2 550	2 450
-	9	-		35,5							60	M6	2 600 ²⁾	2 550 ²⁾
40	15	8,3	22	49	8,4	15	M10	M8X1	NIPA2	-	M8	-	4 550	4 450
-	9	-		43							60	M8	4 650 ²⁾	4 650 ²⁾
44,5	16	9,3	26	52	10,5	18	M12	M8X1	NIPA2	-	M10	-	5 900	5 700
-	11	-		50,5							54	M10	6 000 ²⁾	6 000 ²⁾
56	20	12,4	34	64	13	20	M16	M8X1	NIPA2	-	M12	-	8 800	9 700
-	14	-		66							54	M12	9 200 ²⁾	9 900 ²⁾
60	20	11,1	34	70	13	20	M16	M8X1	NIPA2	-	M12	-	12 600	14 100
-	14	-		77							54	M12	13 200 ²⁾	14 500 ²⁾

Machined range

Linear flanged ball bearing and housing unit

Sealed

Greased,
with relubrication facility



KFB..-PP-AS

Dimension table - Dimensions in mm

Designation	Mass m ≈ g	Dimensions			Mounting dimensions				
		F _w	B	L	L ₅	L ₆	L ₇	A ₃	
									Tolerances
KFB12-PP-AS	90	12	$\begin{matrix} +0,008 \\ 0 \end{matrix}$	42	32	21,5	6	4,5	11,5
KFB16-PP-AS	120	16	$\begin{matrix} +0,009 \\ -0,001 \end{matrix}$	50	36	23,5	8	5,5	12,5
KFB20-PP-AS	220	20	$\begin{matrix} +0,009 \\ -0,001 \end{matrix}$	60	45	29,8	10	6,7	15,8
KFB25-PP-AS	420	25	$\begin{matrix} +0,011 \\ -0,001 \end{matrix}$	74	58	42	12	7	22
KFB30-PP-AS	640	30	$\begin{matrix} +0,011 \\ -0,001 \end{matrix}$	84	68	50	14	8	26
KFB40-PP-AS	1 230	40	$\begin{matrix} +0,013 \\ -0,002 \end{matrix}$	108	80	58,3	16	9,7	30,3
KFB50-PP-AS	2 150	50	$\begin{matrix} +0,013 \\ -0,002 \end{matrix}$	130	100	74,8	18	11,2	38,6

- 1) The basic load ratings are only valid for hardened (670 HV + 170 HV) and ground shaft raceways.
- 2) For fixing screws to ISO 4762-8.8. If there is a possibility of settling, the fixing screws should be secured against rotation.
- 3) Lubrication nipple. Design and dimensions see page 31.

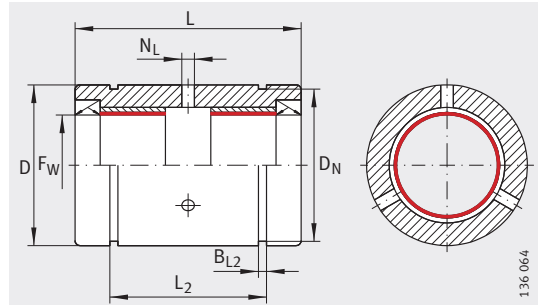


N ₁	N ₃	K ₅ ²⁾	D ₁	R ₁	J _B	K ₈ ³⁾	Ball rows	Basic load ratings ¹⁾	
							Quantity	dyn. C N	stat. C ₀ N
5,5	10	M5	36	2	30	NIPA1	5	540	385
5,5	10	M5	40	2	35	NIPA1	5	710	530
6,6	11	M6	46	2	42	NIPA1	6	1 570	1 230
6,6	11	M6	54	3	54	NIPA1	6	2 800	2 220
9	15	M8	62	3	60	NIPA1	6	3 600	2 850
11	18	M10	80	4	78	NIPA1	6	6 000	4 400
11	18	M10	98	4	98	NIPA2	6	8 700	6 300

Permaglide® plain bearing range

Linear plain bearings

Closed or
with segment cutout
Sealed
Greased,
with relubrication facility



PAB...PP-AS, PABO...PP-AS

Dimension table - Dimensions in mm

Designation		Mass m ≈g	Dimensions			Mounting dimensions	
			F_W	$D^{1)}$ h7	L h12	$L_2^{2)}$ H13	$B_{L2}^{3)}$ H13
PAB12-PP-AS	–	26	12	22	32	22,6	1,3
–	PABO12-PP-AS	21					
PAB16-PP-AS	–	34	16	26	36	24,6	1,3
–	PABO16-PP-AS	28					
PAB20-PP-AS	–	68	20	32	45	31,2	1,6
–	PABO20-PP-AS	58					
PAB25-PP-AS	–	132	25	40	58	43,7	1,85
–	PABO25-PP-AS	113					
PAB30-PP-AS	–	169	30	47	68	51,7	1,85
–	PABO30-PP-AS	143					
PAB40-PP-AS	–	426	40	62	80	60,3	2,15
–	PABO40-PP-AS	362					
PAB50-PP-AS	–	773	50	75	100	77,3	2,65
–	PABO50-PP-AS	657					

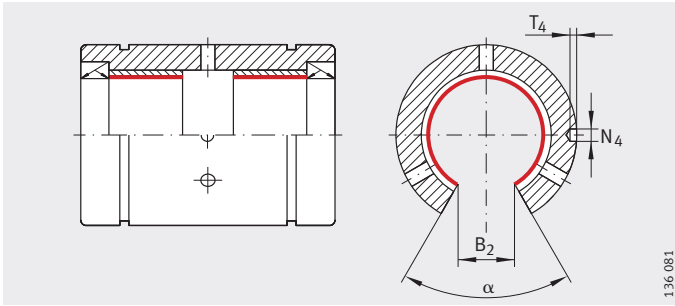
1) The tolerance is only valid for PAB...PP-AS.

2) Holes symmetrical to bearing length L.

3) Slot dimensions suitable for retaining rings to DIN 471.

4) Dimension B_2 on diameter F_W .

5) The basic static load ratings are not valid if the bearings above are fitted – as shown on the following pages – in housings.



PABO..PP-AS
Segment cutout and fixing hole

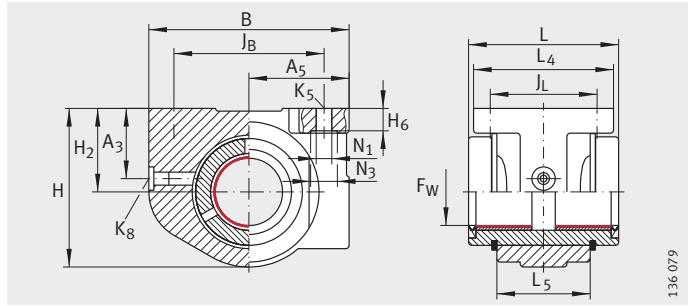
D _N	B ₂ ⁴⁾	T ₄	N ₄	N _L H13	α °	Basic load ratings ⁵⁾
						stat. C ₀ N
21	–	–	–	2,5	–	60 000
	7,6	1,2	2,2		78	
24,9	–	–	–	2,5	–	96 000
	10,1	1,2	2,2		78	
30,3	–	–	–	2,5	–	150 000
	10	1,2	2,2		60	
37,5	–	–	–	2,5	–	250 000
	12,5	1,5	3		60	
44,5	–	–	–	3	–	375 000
	13,6	1,5	3		54	
59	–	–	–	3	–	600 000
	18,2	1,5	3		54	
72	–	–	–	4	–	1 000 000
	22,7	1,5	3		54	



Permaglide® plain bearing range

Linear plain bearing units

Closed
or with segment cutout
Sealed
Greased,
with relubrication facility



PAGBA...PP-AS, PAGBAO...PP-AS

Dimension table - Dimensions in mm

Designation		Mass m ≈g	Dimensions			Mounting dimensions				
			F _w	B	L h12	H	J _B	A ₅	B ₂ ¹⁾	L ₄
PAGBA12-PP-AS	–	70	12	42	32	34	32 ± 0,15	21 ± 0,01	–	32
–	PAGBAO12-PP-AS	60				30,5		21	7,6	
PAGBA16-PP-AS	–	110	16	50	36	41	40 ± 0,15	25 ± 0,01	–	35
–	PAGBAO16-PP-AS	90				36,8		25	10,1	
PAGBA20-PP-AS	–	180	20	60	45	47,5	45 ± 0,15	30 ± 0,01	–	42
–	PAGBAO20-PP-AS	160				44,5		30	10	
PAGBA25-PP-AS	–	350	25	74	58	60	60 ± 0,2	37 ± 0,01	–	54
–	PAGBAO25-PP-AS	310				56		37	12,5	
PAGBA30-PP-AS	–	480	30	84	68	67	68 ± 0,2	42 ± 0,01	–	60
–	PAGBAO30-PP-AS	430				63,5		42	13,6	
PAGBA40-PP-AS	–	1 070	40	108	80	87	86 ± 0,2	54 ± 0,015	–	78
–	PAGBAO40-PP-AS	910				82,4		54	18,2	
PAGBA50-PP-AS	–	1 650	50	130	100	98	108 ± 0,2	65 ± 0,015	–	70
–	PAGBAO50-PP-AS	1 460				92,8		65	22,7	

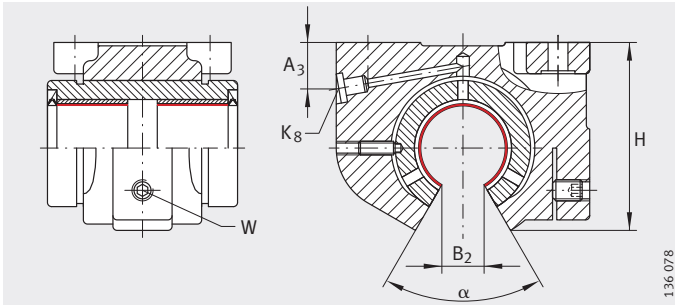
1) Dimension B₂ on diameter F_w.

2) For fixing screws ISO 4 762-8.8.

If there is a possibility of settling, the screws should be secured against rotation.

3) Note maximum tightening torques.

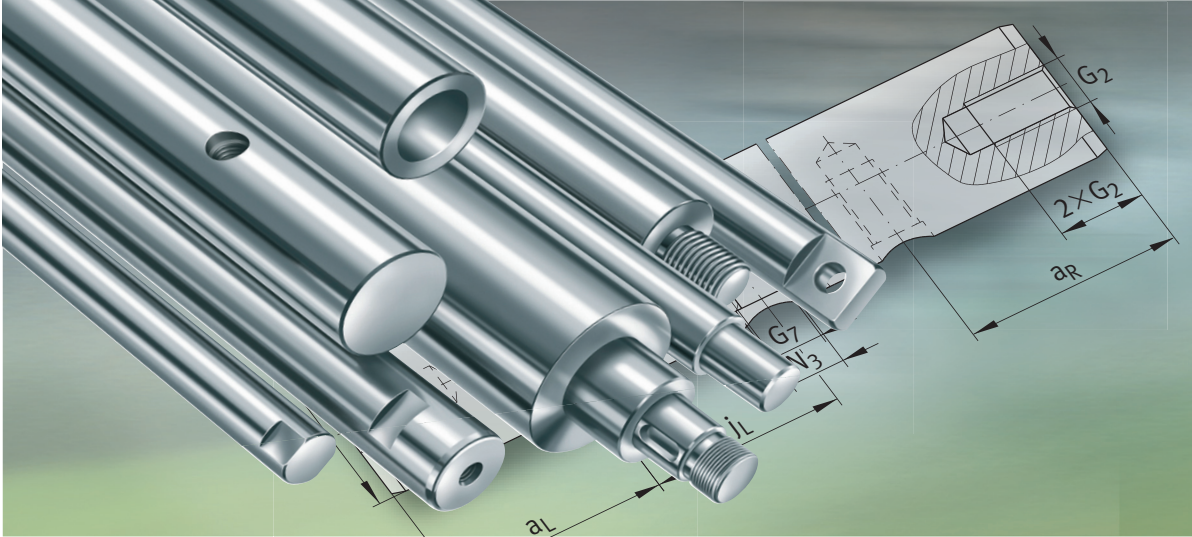
4) Designs and dimensions see page 31.



PAGBAO..-PP-AS
Segment cutout

J _L	L ₅	H ₂	A ₃	H ₆ -0,5	N ₁ ²⁾	N ₃ ²⁾	K ₅	Width across flats W ³⁾		α °	K ₈	Lubrication nipple ⁴⁾
									max. Nm			
23±0,15	20	18±0,01	15	4,8	4,7	8	M4	-	-	-	NIPA1	
		18	7,8					2	1	78		
26±0,15	22	22±0,01	15	5,4	4,7	8	M4	-	-	-	NIPA1	
		22	10					2,5	1,5	78		
32±0,15	28	25±0,01	21	6,7	4,7	8	M4	-	-	-	NIPA1	
		25	11					2,5	1,5	60		
40±0,2	40	30±0,01	23	7,8	5,7	10	M5	-	-	-	NIPA1	
		30	13					3	3	60		
45±0,2	48	35±0,01	25	8,7	6,8	11	M6	-	-	-	NIPA2	
		35	14					3	4	54		
58±0,2	56	45±0,01	30	11	9,2	15	M8	-	-	-	NIPA2	
		45	18					4	5	54		
50±0,2	72	50±0,015	34	12,5	9,2	15	M8	-	-	-	NIPA2	
		50	19					4	7	54		








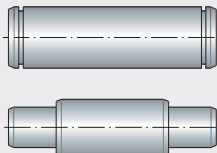
Solid shafts
Hollow shafts

Solid shafts, hollow shafts

	Page
Matrix	Matrix for preselection of solid and hollow shafts 120
Product overview	Solid shafts, hollow shafts 122
Features	High precision raceway for economical linear guidance systems 123
	Steels, hardness, surface, tolerances, lengths 123
	Coatings 124
	Available materials, coatings, tolerances 127
	Solid shafts with threaded holes 128
	Shafts according to customer requirements 129
	Shaft machining, shaft specification 133
Accuracy	Length tolerance 135
	Straightness value to ISO 13 012 135
Ordering example, ordering designation	Solid shaft, without machining 136
	Hollow shaft, without machining 136
	Solid shaft, with machining 136
	Solid shaft, according to customer requirements 137
	Shaft guidance system 138
Dimension tables	Solid shafts 139
	Recommended threaded holes for solid shafts 140
	Hollow shafts 141



**Matrix for preselection
of solid and hollow shafts**

Solid and hollow shafts		Shaft diameter d_{LW} mm from ... to	Normal shaft tolerance
Solid shafts Without threaded holes	W 	4 – 80	h6
Solid shafts With threaded holes	W 	10 – 80	h6
Hollow shafts	WH 	12 – 80	h7
Shafts According to customer requirements	W 	10 – 80	h6, h7

Definition:

- Available by agreement
- Available

1) Not available for all diameters.

2) For WH, Cf53 or C60.

Special tolerances, only for shafts made from quenched and tempered steel		Steel			Coating ¹⁾				Description
		Quenched and tempered steel Cf53 ²⁾	Corrosion-resistant steel		Hard chromium plating	Corrotect [®]	Protect A	Protect B	
			X46Cr13	X90CrMoV18					Page
j5	f7	●	■ ¹⁾	■ ¹⁾	■	■	■	■	123
j5	f7	●	■ ¹⁾	■ ¹⁾	■	■	■	■	128
h7	–	●	–	–	■	■	■	■	123
j5	f7	●	■ ¹⁾	■ ¹⁾	■	■	■	■	129

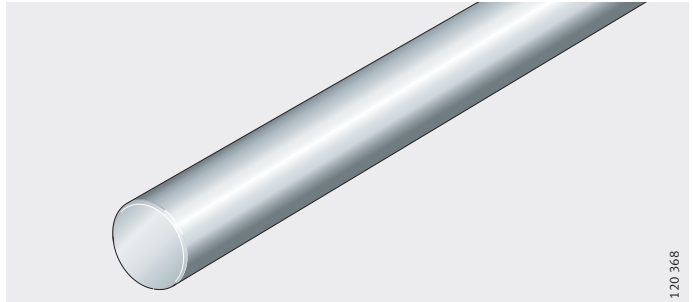


Product overview Solid shafts, hollow shafts

Solid shafts

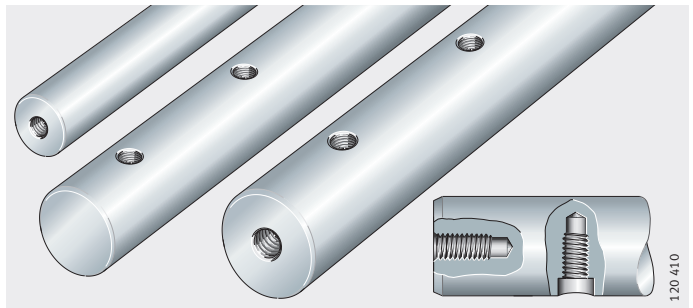
Without threaded holes

W



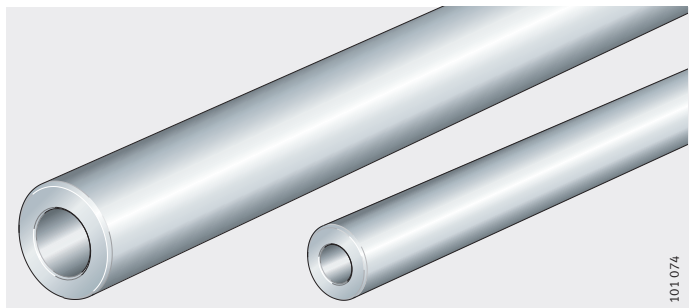
Axial and radial threaded holes

W



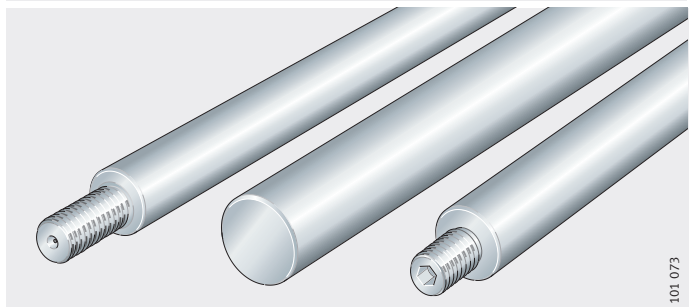
Hollow shafts

WH



Shafts according to customer requirements

W



Solid shafts, hollow shafts

Features Solid and hollow shafts are high precision shafts made from quenched and tempered steel to rolling bearing quality and are supplied in metric sizes.

Hollow shafts are particularly suitable for reduced-mass designs. For location, solid shafts can be provided with radial and axial threaded holes or can, by agreement, be produced completely in accordance with a customer drawing, see page 128 to page 132.

High precision raceway for economical linear guidance systems

The material quality guarantees high dimensional and geometrical accuracy (roundness, parallelism). Due to their high surface hardness and surface quality, the shafts are highly suitable as precision raceways for linear ball bearings.

High precision shafts are also suitable as guide rods for plain bushes, as stretch and levelling rollers and in the construction of equipment and automatic machinery.

They can be combined with linear bearings, yoke and stud type track rollers, ball bearing track rollers and profiled track rollers to give linear guidance systems that are rigid, precise, economical and ready to fit, with high load carrying capacity and a long operating life.

Steels, hardness, surface, tolerances, lengths

Shafts made from Cf53 are induction hardened and ground; the surface hardness is 670 HV + 170 HV (59 HRC + 6 HRC).

Hollow shafts are only available made from quenched and tempered steel.

Shafts made from corrosion-resistant steel to ISO 683-17 and EN 10 880

As an alternative to quenched and tempered steel, solid shafts are also available in corrosion-resistant steels, for example X46Cr13 (material number 1.4034), or X90CrMoV18 (material number 1.4112).

The surface hardness is 550 HV + 70 HV (54 HRC + 4 HRC).

These steels are particularly suitable for use in the foodstuffs industry, medical equipment and semiconductor technology.

The suffix is X46 or X90.

Attention!

Due to the hardness curve, the corrosion resistance of shafts made from the materials X46Cr13 and X90CrMoV18 is restricted at the end faces. This also applies to any soft-annealed areas.

Hardness, surface, tolerances, lengths

A uniform hardening depth will ensure a smooth transition from the hardened surface layer to the tough, normally annealed core, which can support bending stresses.

The standard surface is $R_a 0,3$.

Solid shafts have the normal tolerance h6, while hollow shafts have h7.

High precision shafts are available in single piece lengths up to 6 000 mm. Longer shafts are available by agreement and are assembled (with mortice and tenon joints).

Available steels and tolerances see also page 127.



Solid shafts, hollow shafts

Coatings

Coatings and hard chromium plating provide optimum anti-wear and anti-corrosion protection for shafts and are optional. The characteristics of the coatings are also shown in the table Coatings, page 126.

Hard chromium plating – Anti-wear protection

Hard chromium plating is suitable for applications in which a high degree of anti-wear protection is required. The chromium coating also offers good corrosion resistance.

Chromium plated shafts are to tolerance h7. The thickness of the chromium coating is at least 5 µm, the hardness is 800 HV to 1050 HV.

The suffix is CR.

Corrotect® – Anti-corrosion protection

Corrosion-resistant shafts are coated with the special coating Corrotect® and, for production reasons, have centring or threaded holes in the end faces.

The inside diameter of hollow shafts is not coated.

Corrotect® is resistant to neutral, organic fluids such as oil, brake fluid and petrol. For applications where aqueous salt solutions in the pH range from 5 to 10 are present, Corrotect® is also suitable due to its good resistance.

The suffix is RRF.

The structure of the coating is shown in *Figure 1*.

Attention!

Corrotect® reduces the adhesion of weld spatter.

Corrotect® can be worn away by contact seals.

The coating is not permitted for direct contact with foodstuffs and is not suitable in abrasive ambient media.

- ① Chromate layer
- ② ZnFe layer
- ③ Substrate

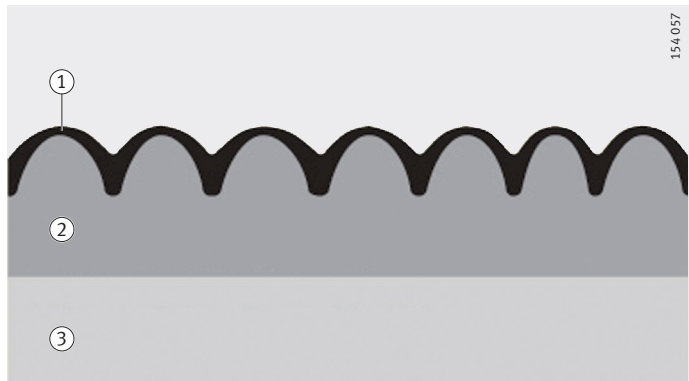


Figure 1
Structure of Corrotect® coating

**Protect A –
Anti-corrosion and
anti-wear protection**

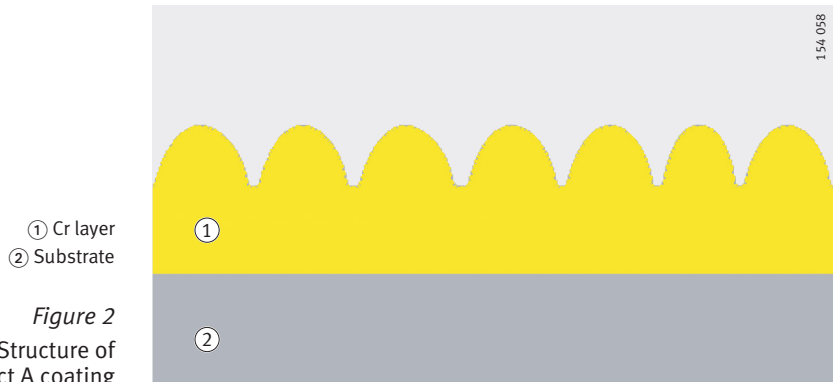
Protect A is a columnar thin layer chromium plating. The matt grey chromium layer with its pearl structure retains a certain amount of lubricant between the pearls. As a result, effective anti-wear protection is achieved even under mixed friction or slippage conditions. During running-in, the rolling elements and seals burnish the surface. This leads to a reduced coefficient of friction.

The anti-wear coating Protect A has no influence on the load carrying capacity and has good thermal conductivity.

The inside diameter of hollow shafts is not coated.

The suffix is KD.

The structure of the coating is shown in *Figure 2*.



**Protect B –
Anti-corrosion
and high anti-wear protection**

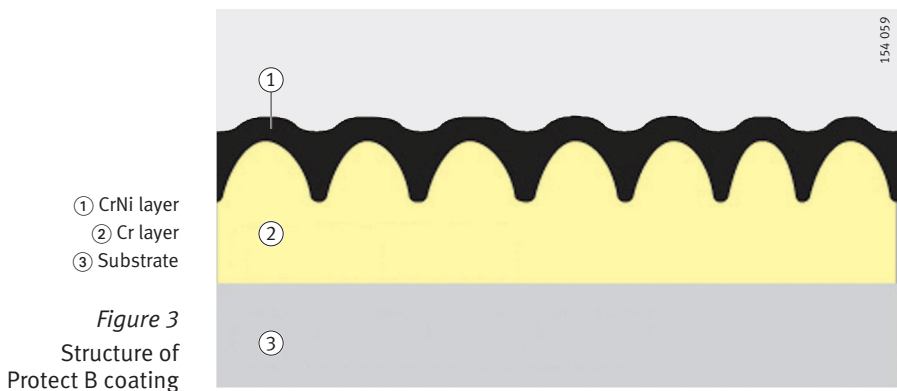
A columnar thin layer chromium plating is covered by chromium mixed oxide. This gives a high level of anti-wear protection and good corrosion resistance.

The chromium mixed oxide layer acts in a supportive capacity to the lubricant when used in aggressive atmospheres and at high temperatures.

The inside diameter of hollow shafts is not coated.

The suffix is KDC.

The structure of the coating is shown in *Figure 3*.



Solid shafts, hollow shafts

Coatings

Feature	Coating			
	Corrotect®	Protect A	Protect B	Hard chromium plating
Colour	Black	Matt grey	Black	Chromium
Layer thickness in μm	0,5 – 5,0	2,0 – 5,0	2,0 – 5,0	5,0 – 15,0
Composition	Zinc alloyed with iron and cobalt	Pure chromium layer with pearly surface	Protect A with chromium-nickel LC coating	Chromium
Coating hardness in HV	300	950 – 1300	950	800 – 1050
Anti-corrosion protection in h	96	8	96	120
Anti-wear protection	–	Under mixed friction	Under inadequate lubrication	yes
Maximum shaft length in mm	3 500	3 500	3 500	4 000

Attention! Machined surfaces, end faces and bores may be uncoated.

**Available materials,
coatings, tolerances**
Solid and hollow shafts

Shaft diameter	Solid shafts							Hollow shafts
	Material							
	Quenched and tempered steel					X46Cr13	X90CrMoV18	Quenched and tempered steel
	Tolerance ⁵⁾			CR ¹⁾	RRF ²⁾ KD ³⁾ KDC ⁴⁾			Tolerance
mm	h6	j5	f7	h7	h7	h6	h6	h7
4	●	-	-	-	■	●	●	-
5	●	-	-	-	■	-	-	-
6	●	-	-	●	■	●	●	-
8	●	-	-	●	■	●	●	-
10	●	-	-	●	■	●	●	-
12	●	-	-	●	■	●	●	-
14	●	-	-	●	■	●	●	-
15	●	-	●	●	■	●	●	-
16	●	●	●	●	■	●	●	-
18	●	-	●	●	■	●	●	-
20	●	●	●	●	■	●	●	●
24	●	-	-	-	■	●	●	-
25	●	●	●	●	■	●	●	●
30	●	●	●	●	■	●	●	●
32	●	●	●	-	■	●	●	-
40	●	●	-	●	■	●	●	●
50	●	●	-	●	■	●	●	●
60	●	-	-	●	■	●	●	●
80	●	-	-	●	■	●	●	●

■ Available by agreement.

● Available design.

1) Hard chromium plating see page 124.

2) Corrotect® coating see page 124.

3) Protect A coating see page 125.

4) Protect B coating see page 125.

5) Other tolerances available by agreement.



Solid shafts, hollow shafts

Solid shafts with threaded holes

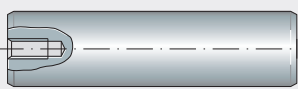
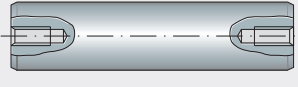
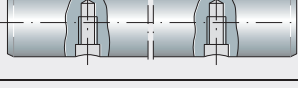


Where shafts are to be supported or connected to other elements, fixing holes are required.

The standard threaded holes for solid shafts are defined as hole patterns 01 to 05 in accordance with the table Codes for hole patterns.

In addition, holes may be made in accordance with a customer drawing with or without threads, *Figure 4 to Figure 16*.

Ordering examples see page 136.

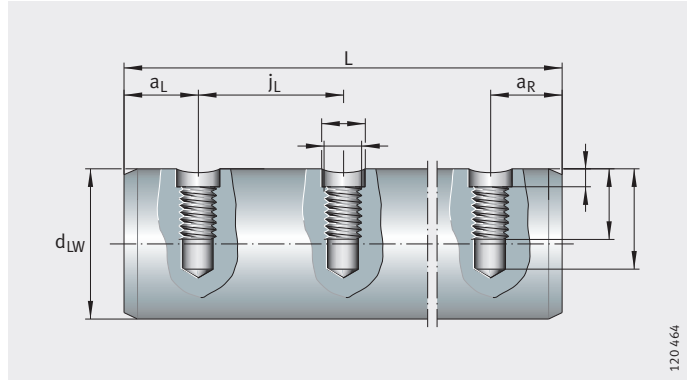
Codes for hole patterns

Code		Design of holes
01		Axial threaded hole on one side
02		Axial threaded holes on both sides
03		Radial threaded hole
04		Radial threaded holes and axial threaded hole on one side
05		Radial threaded holes and axial threaded holes on both sides

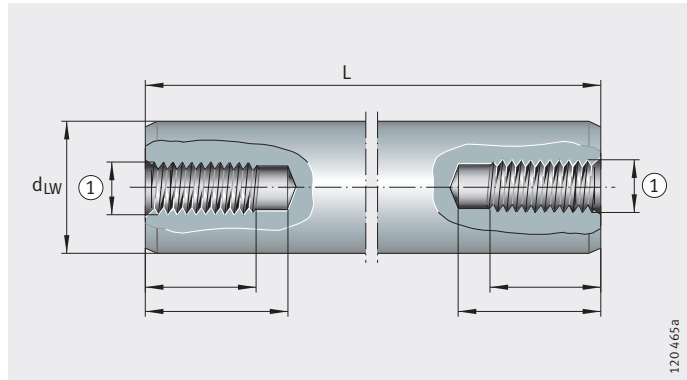
Shafts according to customer requirements

When placing enquiries for special shafts, please use a customer drawing or copy our templates and add the required values, see *Figure 4 to Figure 16*.

Figure 4
Radial holes with and without threads

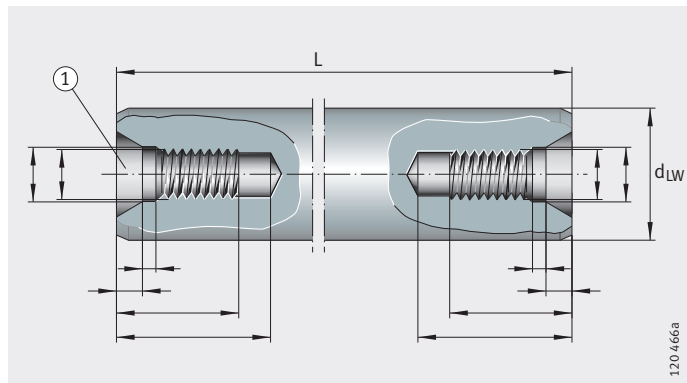


① Diameter to DIN 336 or DIN 13
Figure 5
Internal threaded hole, on one or both sides



① For threaded hole with centring hole DIN 332-D recommended

Figure 6
Internal threaded hole with centring hole



Solid shafts, hollow shafts

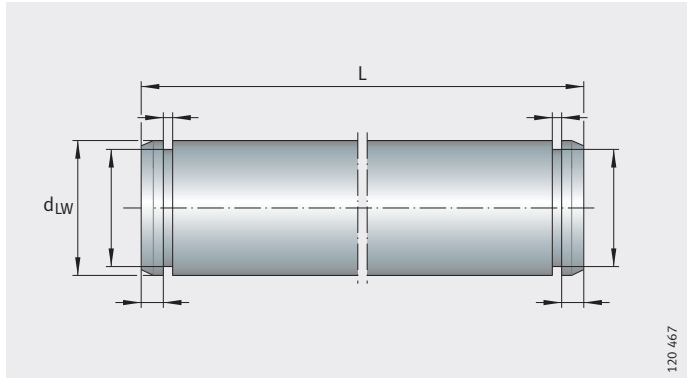


Figure 7
Undercut for retaining ring

120 467

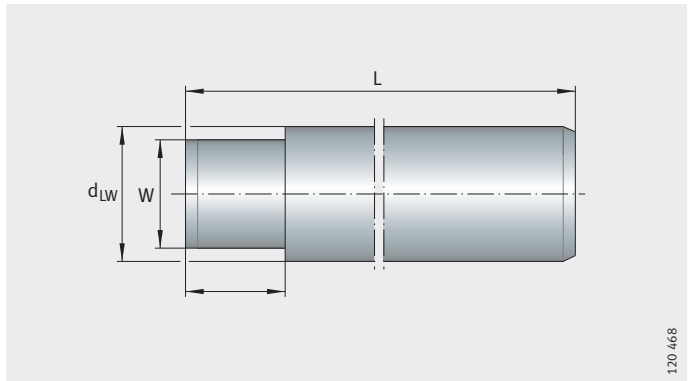
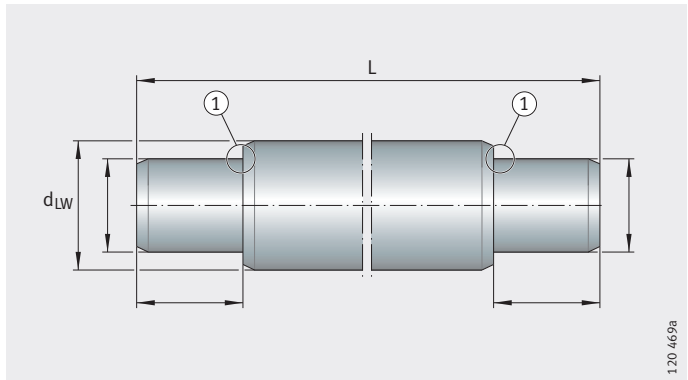


Figure 8
Width across flats W

120 468



① Or undercut type F
DIN 509 (both sides)

Figure 9
Journal

120 469

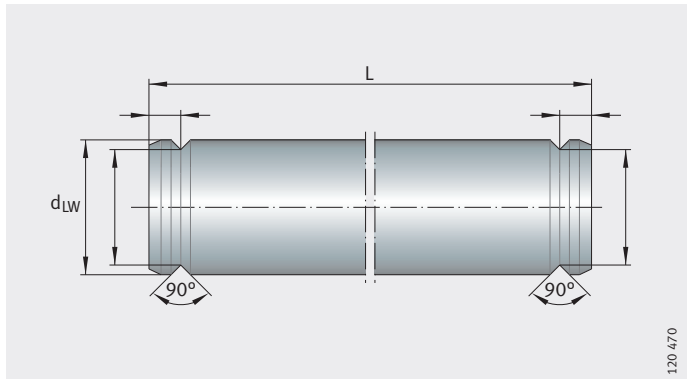
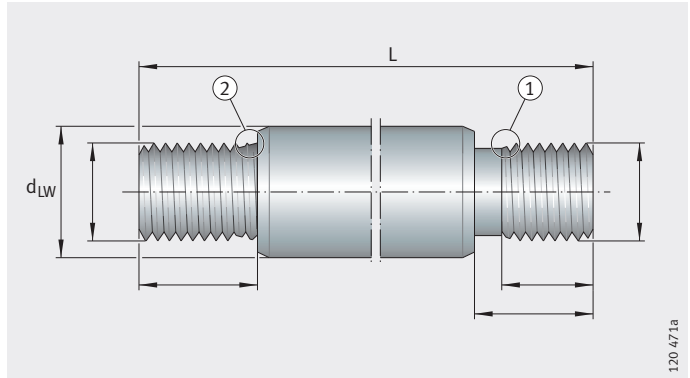


Figure 10
90° undercut

120 470

- ① Thread runout to DIN 76-a1, with undercut to DIN 76-A
- ② With undercut DIN 76-A recommended

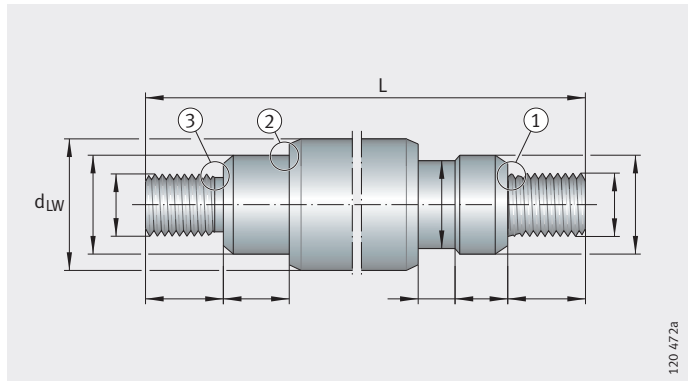
Figure 11
Threaded journal



120 471a

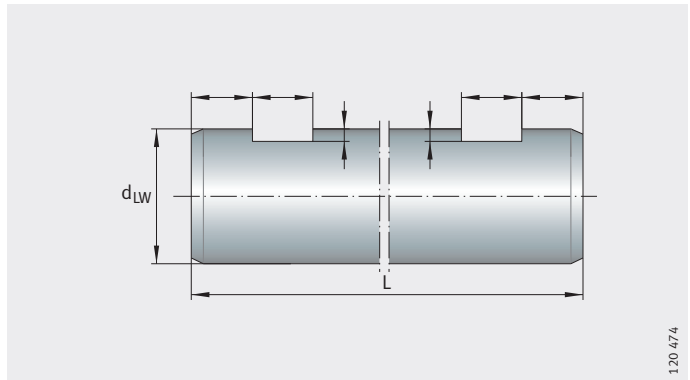
- ① With undercut DIN 76-A recommended
- ② With undercut type F DIN 509 recommended
- ③ Thread runout to DIN 76-a1

Figure 12
Journal and threaded journal



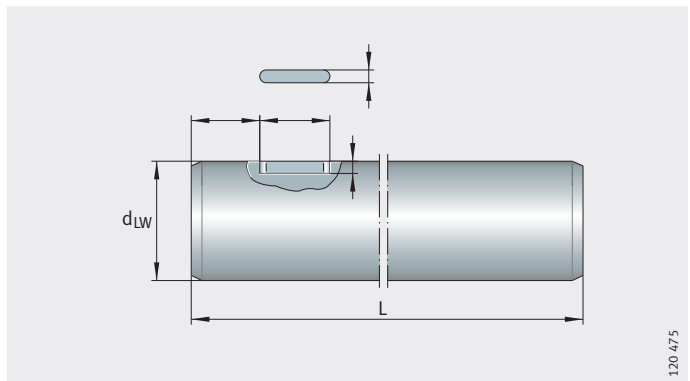
120 472a

Figure 13
Slot



120 474

Figure 14
Keyway



120 475



Solid shafts, hollow shafts

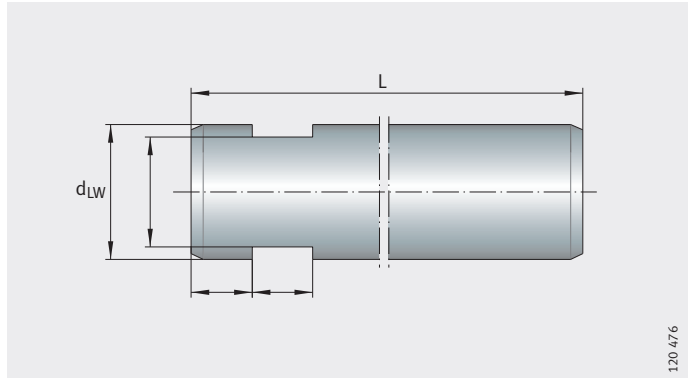


Figure 15
Width across flats

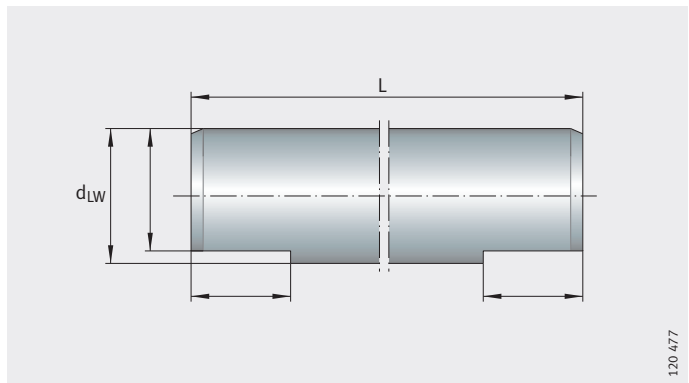


Figure 16
Flattened area

Shaft machining, shaft specification

Soft annealed shafts

Additional machining (such as journals, flattened areas, external threads) may require soft annealing of the corresponding areas. Slight changes may occur in the dimensional and geometrical tolerances as well as the surface quality of the soft annealed area, *Figure 17*. Material discoloration may occur in the annealed area and there may be residual hardness in the transitional zone.

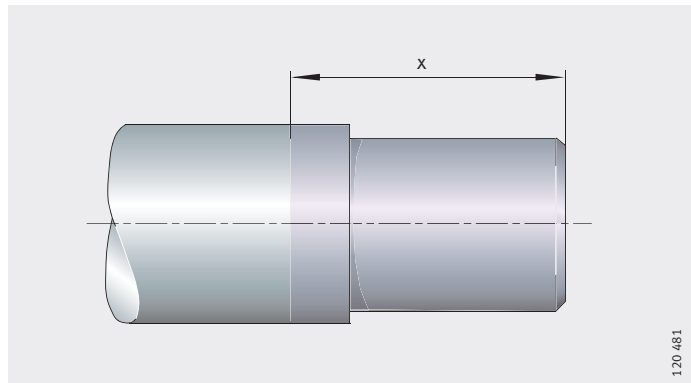
Attention!

In the case of corrosion-resistant steels, the X class materials, the anti-corrosion protection is restricted here.

x = soft annealed area

Figure 17

Soft annealed shaft



Standard chamfer

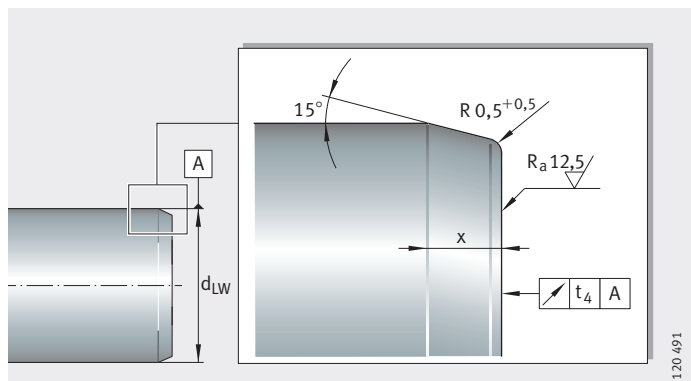
After cutting to length, both ends of the shaft are chamfered, *Figure 18* and table Chamfer, as a function of shaft diameter. However, they can also be supplied without chamfers as a parting cut, *Figure 19*, page 134.

Chamfer, as a function of shaft diameter

Shaft diameter d_{LW} mm	Chamfer x mm	Runout t_4 mm
$d_{LW} \leq 10$	1^{+1}	0,2
$10 < d_{LW} \leq 30$	$1,5^{+1}$	0,3
$30 < d_{LW} \leq 80$	$2,5^{+1}$	0,5

Figure 18

Standard chamfer



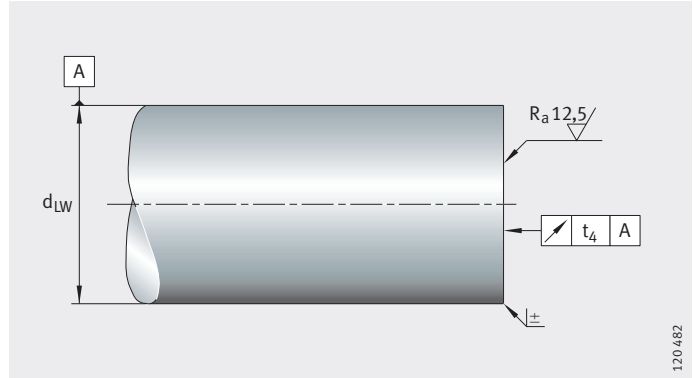
Solid shafts, hollow shafts

Parting cut

In the case of a parting cut, the shaft is only cut to length, *Figure 19*. There is no additional machining of the end faces. A burr may be present. The suffix is T.

t_4 = runout tolerance, table, page 133

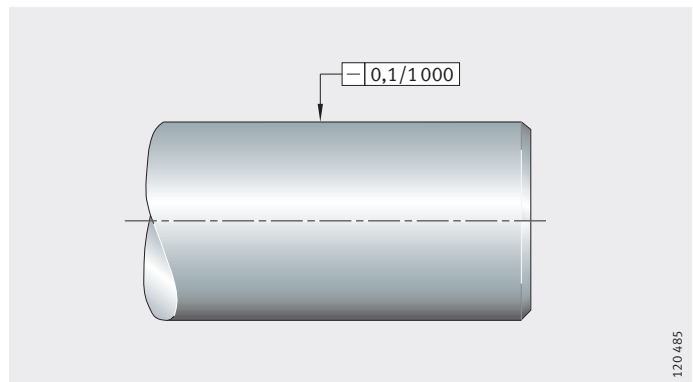
Figure 19
Parting cut



Straightness

The standard straightness is shown in *Figure 20*.

Figure 20
Straightness

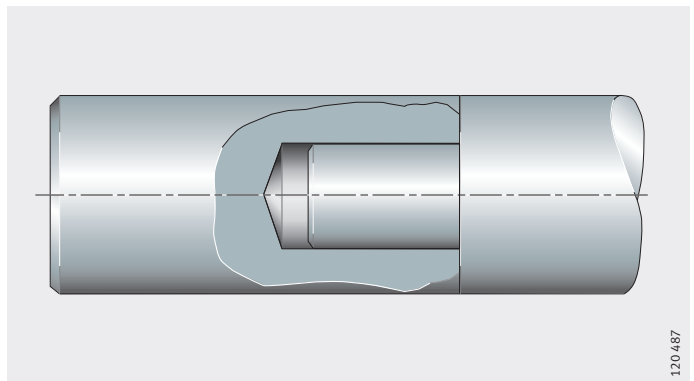


Shafts with mortice and tenon joint

If the shaft length is in excess of the stock length, the shafts are joined together.

The individual sections of shafts are joined by means of mortice and tenon joints, *Figure 21*. The joints are marked accordingly. Shafts screwed together are available by agreement.

Figure 21
Shaft with mortice and tenon joint



Accuracy
Length tolerance

Length tolerances are dependent on the shaft length, see table Tolerance and *Figure 22*.

Special tolerances are available by agreement.

Tolerance

Shaft length l L mm		Tolerance mm
over	incl.	max.
-	400	±0,5
400	1 000	±0,8
1 000	2 000	±1,2
2 000	4 000	±2
4 000	6 000	±3

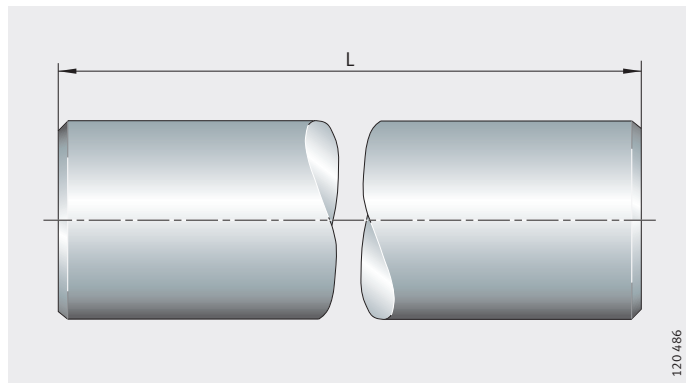


Figure 22
Length tolerance

Straightness value to ISO 13 012

The measurement points are separated by a distance of 1 000 mm. Shafts < 1 000 mm have a maximum of two measurement points, *Figure 23*.

The straightness tolerance is half of the dial gauge value with a shaft revolution of 360°.

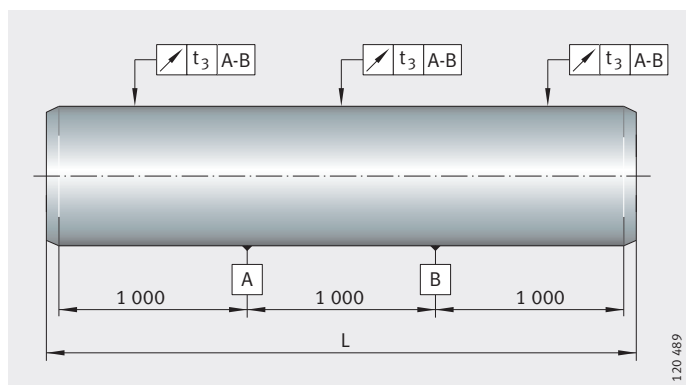


Figure 23
Straightness measurement

Solid shafts, hollow shafts

Ordering example, ordering designation

Solid shaft, without machining

Type	W
Shaft diameter d_{LW}	20
Tolerance	h6
Material	Cf53
Coating	–
Length	1200
Parting cut	–
Standard chamfer	No suffix

Ordering designation **W20/h6-Cf53-1 200**

Hollow shaft, without machining

Type	WH
Shaft diameter d_{LW}	20
Tolerance	h7
Material	C60
Coating	–
Length	1500
Parting cut	T
Standard chamfer	–

Ordering designation **WH20/h7-C60-1 500-T**

Solid shaft, with machining

Type	W
Shaft diameter d_{LW}	30
Tolerance	h6
Material	Cf53
Coating	Cr
Hole pattern	05
Axial threaded hole	M12
Radial threaded hole	M10
Hole pitch, radial threaded hole	100
Length	1110
Parting cut	T
Standard chamfer	–
Pitch a_L	60
Pitch a_R	50

Ordering designation **W30/h6-Cf53-Cr-05-M12-M10×100-1110-T-60-50**

**Solid shaft,
according to
customer requirements**

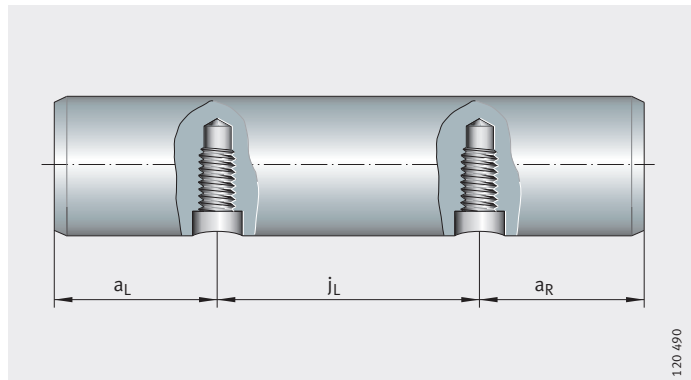
If the standard designations are not sufficient to describe the shaft, please submit a drawing with your enquiry.

**Possible ordering designation
for standard shafts**

Type	W, WH
Shaft diameter d_{LW}	10 to 80
Tolerance ¹⁾	h6, h7, j5, f7
Material ²⁾	Cf53, C60, X46, X90
Coating	Cr, KD, KDC, RRF
Hole pattern	01, 02, 03, 04, 05
Axial threaded hole ³⁾	M3 to M24
Radial threaded hole ³⁾	M4 to M14
Hole pitch	Measured from centre point of hole, <i>Figure 24</i>
Radial threaded hole j_L	<i>Figure 24</i>
Length ³⁾	Single piece up to 6 000
Parting cut	T
Standard chamfer	No suffix
Pitch a_L	Start of shaft – first hole, <i>Figure 24</i>
Pitch a_R	Last hole – end of shaft, <i>Figure 24</i>

- ¹⁾ Available tolerances are dependent on diameter, see dimension table page 139 and page 141.
²⁾ Hollow shafts are only available in Cf53 and C60.
³⁾ Dependent on diameter, see dimension table page 139 to page 141.

Figure 24
Hole pitch
of radial threaded holes j_L



Solid shafts, hollow shafts

Shaft guidance system

Elements of shaft guidance systems (linear ball bearings, solid and hollow shafts) must be ordered separately.

The ordering designation of an element comprises the designation and additional specific data – where necessary, see ordering designation for shaft with axial threaded holes, linear ball bearings and *Figure 25*.

The designations are given in the dimension tables. The unit is described in greater detail by means of the additional data.

Required

A shaft guidance system in a corrosion-resistant design with two sealed and corrosion-resistant linear ball bearings.

Shaft with axial threaded holes

Corrosion-resistant shaft	W20/h6-X90
Code for hole pattern	02
Axial threaded hole	M8
Shaft length	3500

Ordering designation

1×**W20/h6-X90-02-M8-3500**

Linear ball bearings

Linear ball bearings	KB
Size code	20
Contact seal on both end faces	PP
Corrotect® coating	RR
Relubrication facility	AS

Ordering designation

2×**KB20-PP-RR-AS**

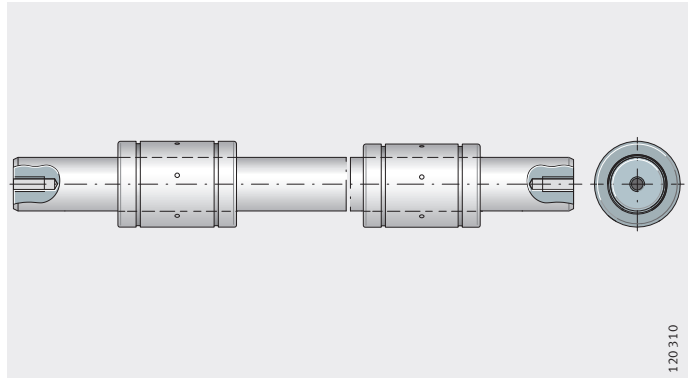
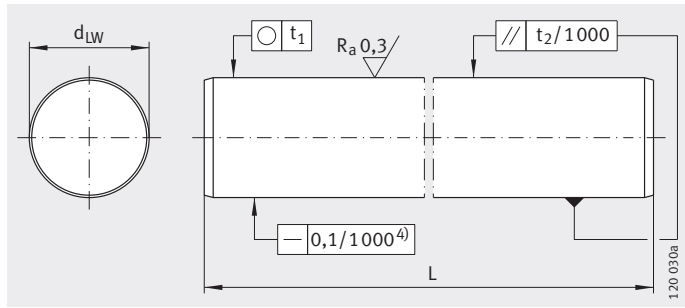


Figure 25

Shaft with axial threaded holes,
two linear ball bearings

Solid shafts



W

Dimension table - Dimensions in mm

Designation	Mass m ≈kg/m	Dimensions		Tolerance			Roundness t ₁ μm	Parallelism t ₂ ²⁾ μm	Effective hardening depth Rht ³⁾ min.
		d _{LW}	L	Tolerance h6 μm	Special tolerance ¹⁾				
					j5 μm	f7 μm			
W04	0,1	4	2 500	$\begin{smallmatrix} 0 \\ -8 \end{smallmatrix}$	—	—	4	5	0,4
W05	0,15	5	3 600	$\begin{smallmatrix} 0 \\ -8 \end{smallmatrix}$	—	—	4	5	0,4
W06	0,22	6	4 000	$\begin{smallmatrix} 0 \\ -8 \end{smallmatrix}$	—	—	4	5	0,4
W08	0,39	8	4 000	$\begin{smallmatrix} 0 \\ -9 \end{smallmatrix}$	—	—	4	6	0,4
W10	0,62	10	6 000	$\begin{smallmatrix} 0 \\ -9 \end{smallmatrix}$	—	—	4	6	0,4
W12	0,89	12	6 000	$\begin{smallmatrix} 0 \\ -11 \end{smallmatrix}$	—	—	5	8	0,6
W14	1,21	14	6 000	$\begin{smallmatrix} 0 \\ -11 \end{smallmatrix}$	—	—	5	8	0,6
W15	1,39	15	6 000	$\begin{smallmatrix} 0 \\ -11 \end{smallmatrix}$	—	$\begin{smallmatrix} -16 \\ -34 \end{smallmatrix}$	5	8	0,6
W16	1,58	16	6 000	$\begin{smallmatrix} 0 \\ -11 \end{smallmatrix}$	$\begin{smallmatrix} +5 \\ -3 \end{smallmatrix}$	$\begin{smallmatrix} -16 \\ -34 \end{smallmatrix}$	5	8	0,6
W18	2	18	6 000	$\begin{smallmatrix} 0 \\ -11 \end{smallmatrix}$	—	$\begin{smallmatrix} -16 \\ -34 \end{smallmatrix}$	5	8	0,6
W20	2,47	20	6 000	$\begin{smallmatrix} 0 \\ -13 \end{smallmatrix}$	$\begin{smallmatrix} +5 \\ -4 \end{smallmatrix}$	$\begin{smallmatrix} -20 \\ -41 \end{smallmatrix}$	6	9	0,9
W24	3,55	24	6 000	$\begin{smallmatrix} 0 \\ -13 \end{smallmatrix}$	—	—	6	9	0,9
W25	3,85	25	6 000	$\begin{smallmatrix} 0 \\ -13 \end{smallmatrix}$	$\begin{smallmatrix} +5 \\ -4 \end{smallmatrix}$	$\begin{smallmatrix} -20 \\ -41 \end{smallmatrix}$	6	9	0,9
W30	5,55	30	6 000	$\begin{smallmatrix} 0 \\ -13 \end{smallmatrix}$	$\begin{smallmatrix} +5 \\ -4 \end{smallmatrix}$	$\begin{smallmatrix} -20 \\ -41 \end{smallmatrix}$	6	9	0,9
W32	6,31	32	6 000	$\begin{smallmatrix} 0 \\ -16 \end{smallmatrix}$	+6,5	$\begin{smallmatrix} -25 \\ -50 \end{smallmatrix}$	7	11	1,5
W40	9,87	40	6 000	$\begin{smallmatrix} 0 \\ -16 \end{smallmatrix}$	$\begin{smallmatrix} +6 \\ -5 \end{smallmatrix}$	—	7	11	1,5
W50	15,41	50	6 000	$\begin{smallmatrix} 0 \\ -16 \end{smallmatrix}$	$\begin{smallmatrix} +6 \\ -5 \end{smallmatrix}$	—	7	11	1,5
W60	22,2	60	6 000	$\begin{smallmatrix} 0 \\ -19 \end{smallmatrix}$	—	—	8	13	2,2
W80	39,45	80	6 000	$\begin{smallmatrix} 0 \\ -19 \end{smallmatrix}$	—	—	8	13	2,2

1) Only for shafts made from quenched and tempered steel.

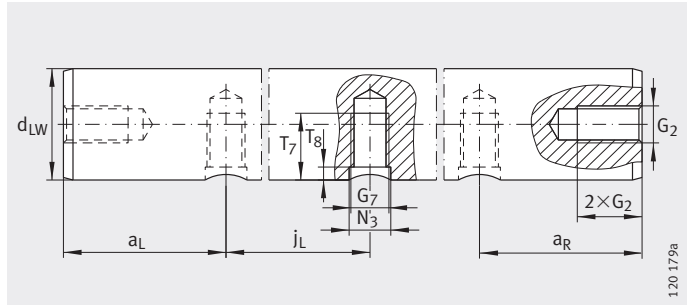
2) Differential diameter measurement.

3) To DIN ISO 13 012.

4) For shaft length < 400 mm max. straightness tolerance of 0,04 mm.



Recommended threaded holes for solid shafts



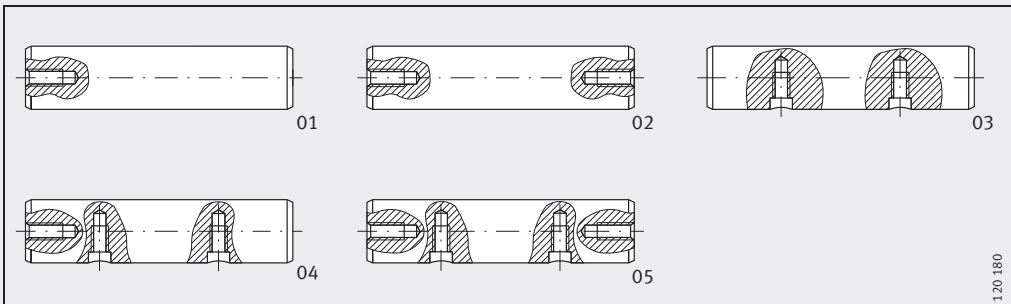
Axial and radial threaded holes

Dimension table - Dimensions in mm

Designation	Axial threaded hole										Radial threaded hole							
	G ₂										j _L	a _L ¹⁾ Hole pattern 03	a _R ¹⁾ Hole pattern 04-05	T ₇	T ₈	N ₃	G ₇	
d _{LW}																		
W08	M3	-	-	-	-	-	-	-	-	-	-	-	-	-	-	-	-	
W10	M3	M4	-	-	-	-	-	-	-	-	-	-	-	-	-	-	-	
W12	-	M4	M5	-	-	-	-	-	-	75	-	120	10	-	7	2	5	M4
W14	-	M4	M5	M6	-	-	-	-	-	-	-	-	-	-	-	-	-	-
W15	-	-	M5	M6	M8	-	-	-	-	-	-	-	-	-	-	-	-	-
W16	-	-	M5	M6	M8	-	-	-	-	75	100	150	15	-	9	2,5	6	M5
W18	-	-	-	M6	M8	M10	-	-	-	-	-	-	-	-	-	-	-	-
W20	-	-	-	-	-	-	-	-	-	-	-	150	15	-	9	2,5	6	M5
W20	-	-	-	M6	M8	M10	-	-	-	75	100	150	15	-	11	3	7	M6
W24	-	-	-	-	M8	M10	M12	-	-	-	-	-	-	-	-	-	-	-
W25	-	-	-	-	-	-	-	-	-	-	-	150	15	-	11	3	7	M6
W25	-	-	-	-	M8	M10	M12	-	-	75	120	200	15	-	15	3	9	M8
W30	-	-	-	-	-	-	-	-	-	-	-	150	15	-	11	3	7	M6
W30	-	-	-	-	-	M10	M12	M16	-	100	150	200	20	-	17	3,5	11	M10
W32	-	-	-	-	-	M10	M12	M16	-	-	-	-	-	-	-	-	-	-
W40	-	-	-	-	-	M10	M12	M16	-	150	200	300	20	-	19	4	11	M10
W40	-	-	-	-	-	M10	M12	M16	-	100	-	-	20	-	21	4	13	M12
W50	-	-	-	-	-	-	-	-	-	-	-	150	20	-	19	4	11	M10
W50	-	-	-	-	-	M12	M16	M20	-	200	300	20	-	-	21	4	13	M12
W50	-	-	-	-	-	M12	M16	M20	-	100	-	-	20	-	25	4	15	M14
W60	-	-	-	-	-	-	M16	M20	M24	-	-	-	-	-	-	-	-	-
W80	-	-	-	-	-	-	M16	M20	M24	-	-	-	-	-	-	-	-	-

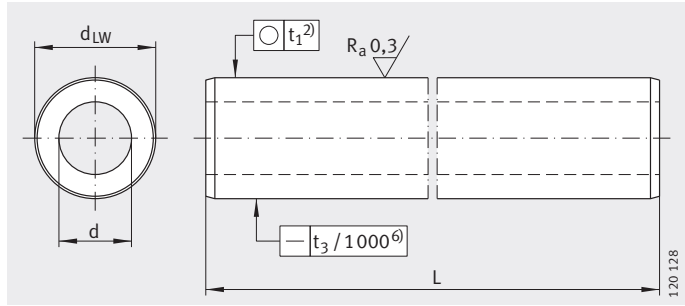
¹⁾ a_L, a_R are dependent on the length of the shaft
Calculation, see page 148.

In the case of variants in accordance with codes 04 and 05, the axial threaded holes must be taken into consideration



Codes 01 to 05 for hole patterns

Hollow shafts



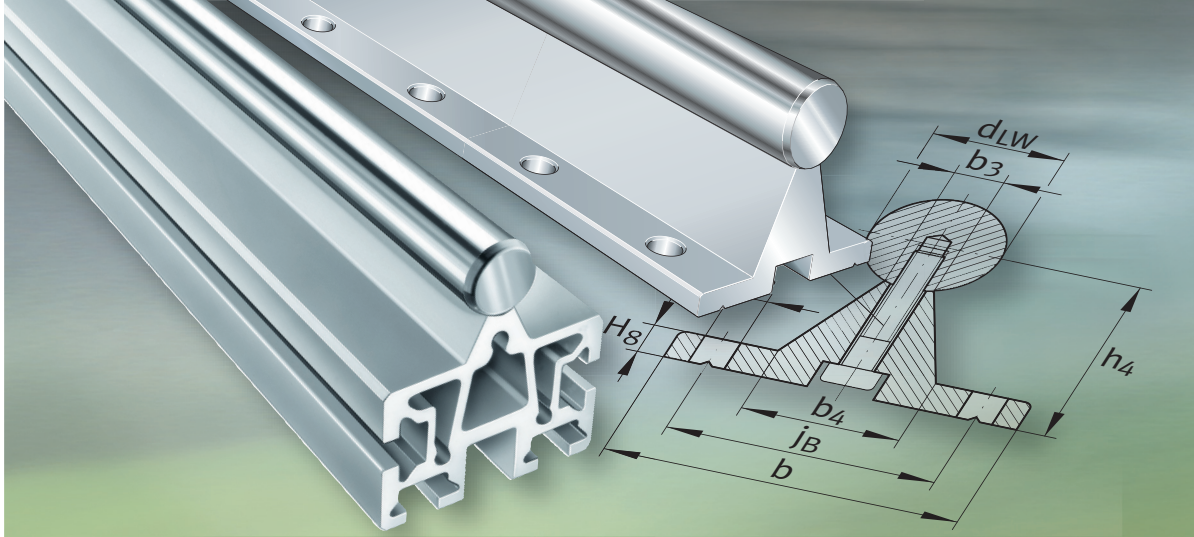
WH

Dimension table · Dimensions in mm

Designation	Mass m ≈kg/m	Dimensions		Inside diameter d ¹⁾	Tolerance d _{LW} h7 ⁵⁾ μm	Effective hardening depth R _{ht} ³⁾ min.	Straightness tolerance t ₃
		d _{LW}	L max.				
WH12 ⁴⁾	0,79	12	6 000	4±0,45	⁰ ₋₁₈	0,6	0,3
WH16	1,26	16	6 000	7±0,3	⁰ ₋₁₈	0,6	0,3
WH20	1,28	20	6 000	14±0,3	⁰ ₋₂₁	0,9	0,2
WH25	2,4	25	6 000	15,5±0,4	⁰ ₋₂₁	0,9	0,2
WH30	3,55	30	6 000	18,2±0,5	⁰ ₋₂₁	0,9	0,2
WH40	5,7	40	6 000	27±1,25	⁰ ₋₂₅	1,5	0,1
WH50	10,58	50	6 000	29±1,25	⁰ ₋₂₅	1,5	0,1
WH60	14,2	60	6 000	36±1,5	⁰ ₋₃₀	2,2	0,1
WH80	20,8	80	6 000	56±1,5	⁰ ₋₃₀	2,2	0,1

- 1) Difference in wall thickness of original material ± 5%.
- 2) The roundness corresponds to no more than half the diameter tolerance.
- 3) To DIN ISO 13 012.
- 4) Available by agreement.
- 5) Diameter tolerance h6 available by agreement.
- 6) For shaft length < 500 mm max. straightness tolerance of 0,1 mm.





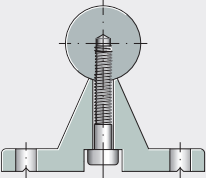
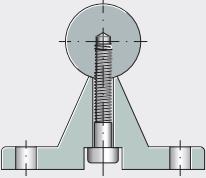
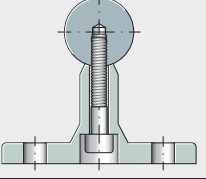
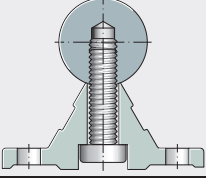
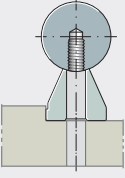

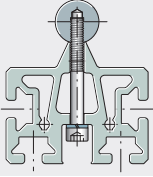
Shaft and support rail units

Shaft and support rail units

	Page
Matrix	Matrix for preselection of shaft and support rail units 144
Product overview	Shaft and support rail units 146
Features	Multi-piece shafts and shaft and support rail units 147
Design and safety guidelines	Hole patterns for shaft and support rail units 148
Accuracy	Length tolerances for shafts and shaft and support rail units 150
Ordering example, ordering designation	Shaft and support rail unit 150 Possible ordering designation for standard shaft and support rail units 150
Dimension tables	Shaft and support rail units 151



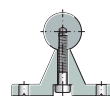
**Matrix for preselection
of shaft and support rail units**

Shaft and support rail units	Precision
TSNW  121 657a	++
TSWW  120 510	++
TSWWA  120 511	++
TSNW..-G4 TSNW..-G5  120 512	+
TSUW  120 513	++
TSSW  120 514	+++
TSMW  120 515	++

Definition:
 +++ Very good
 ++ Good
 + Satisfactory
 ● Available

1) Location by screw mounting from below; threaded hole in the shaft.

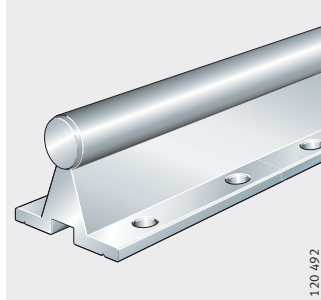
Shaft diameter d_{LW}							Features	Location		Description
								Thread	Through hole	
12	16	20	25	30	40	50			Page	
●	●	●	●	●	●	●	– For location from above	–	yes	147
●	●	●	●	●	●	●	– For location from above – High position of shaft	–	yes	147
●	●	●	●	●	●	●	– For location from above – Narrow crosspiece	–	yes	147
●	●	●	●	●	●	●	– For location from above – Accuracy class (G4, G5) dependent on shaft diameter – Economical	–	yes	147
●	●	●	●	●	●	●	– Threaded holes from below	¹⁾	–	147
–	–	●	●	●	●	●	– For location from side	–	Lateral	147
–	–	●	●	●	–	–	– Self-supporting – With slots – End covers on end faces – For large unsupported spans	Slots	Slots	147



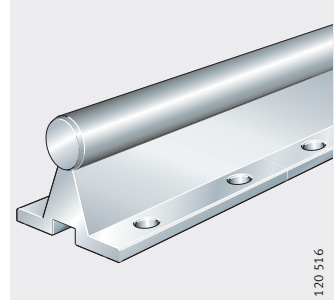
Product overview Shaft and support rail units

Shaft and support rail units

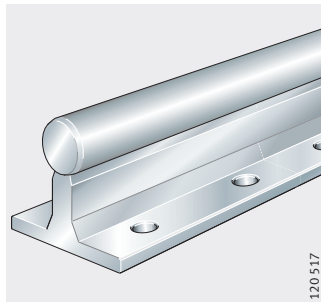
TSNW



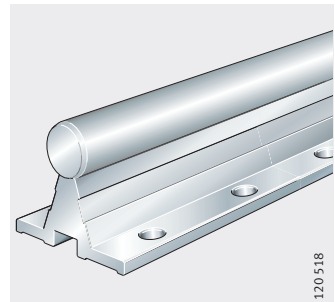
TSWW



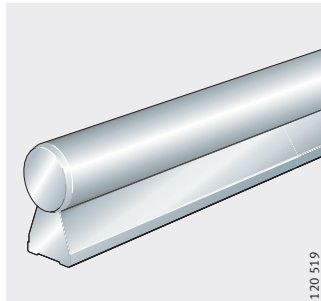
TSWWA



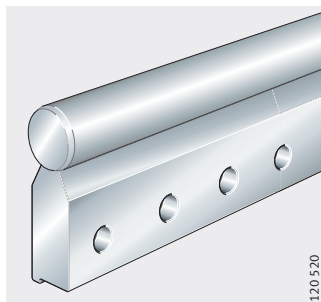
TSNW..-G4, TSNW..-G5



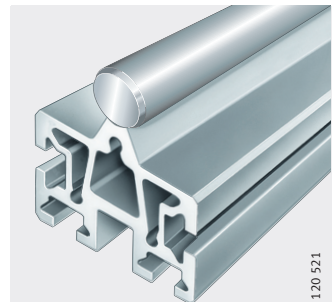
TSUW



TSSW



TSMW



Shaft and support rail units

Features Shaft and support rail units TS..W are composite units comprising a raceway shaft screw mounted to an aluminium support rail. The shaft protrudes approx. 2 mm to 3 mm beyond the end of the support rail at both ends.

The raceway shaft is made from quenched and tempered steel or corrosion-resistant steel (X46), surface hardened and ground. The surface hardness is 670 HV to 840 HV.

Shaft and support rail units are composed of several individual sections depending on their length.

Shafts made from special materials such as those with coatings are available by agreement.

Multi-piece shafts and shaft and support rail units

If the guidance systems are of such a length that shaft and support rail units TS..W cannot be achieved using single-piece shafts, shafts and support rails are supplied as multi-piece units, *Figure 1*. The joint locations on the shaft sections have mortice and tenon joints and are polished.

The joint locations on the shafts and support rails are offset from each other.

The maximum length of single-piece shaft and support rail units is 6 000 mm.

- ① Shaft
- ② Support rail 1
- ③ Support rail 2

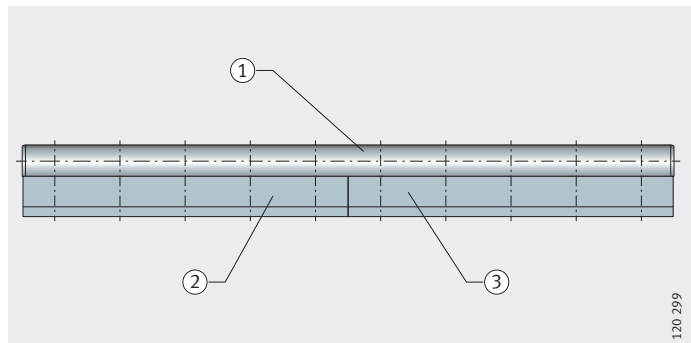


Figure 1
Shaft and support rail unit
with multiple support rail sections



Shaft and support rail units

Design and safety guidelines

Hole patterns for shaft and support rail units

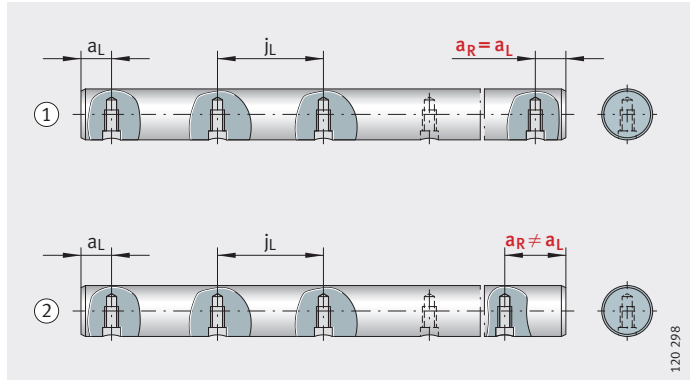
Unless stated otherwise, raceway shafts and shaft and support rail units are supplied with a symmetrical hole pattern, *Figure 2 bis Figure 4*.

An asymmetrical hole pattern may be available at customer request. In this case, $a_{L \max} \geq a_L \geq a_{L \min}$ and $a_{R \max} \geq a_R \geq a_{R \min}$.

- ① Symmetrical hole pattern
- ② Asymmetrical hole pattern

Figure 2

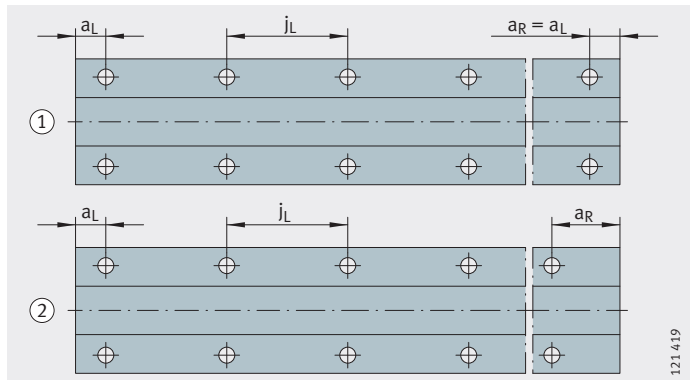
Hole patterns for shafts with one row of holes



- ① Symmetrical hole pattern
- ② Asymmetrical hole pattern

Figure 3

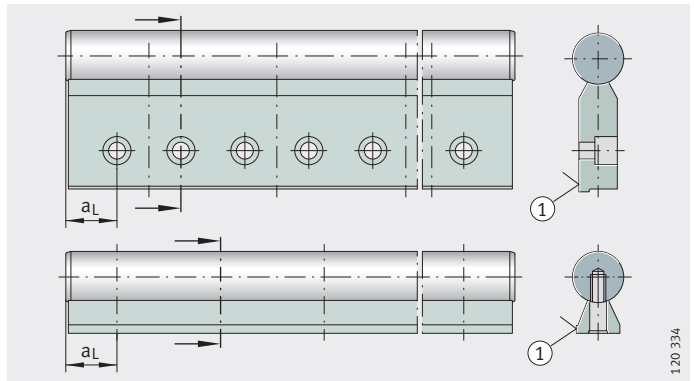
Hole patterns for support rails with two rows of holes



- ① Support rail

Figure 4

Hole patterns for shaft and support rail units TSSW, TSUW



Maximum number of pitches between holes

The number of pitches between holes is the rounded whole number equivalent to:

$$n = \frac{l - 2 \cdot a_{L \min}}{j_L}$$

The distances a_L and a_R are generally determined by:

$$a_L + a_R = l - n \cdot j_L$$

For raceway shafts and shaft and support rail units with a symmetrical hole pattern:

$$a_L = \frac{1}{2} \cdot (l - n \cdot j_L)$$

Number of holes:

$$x = n + 1$$

a_L, a_R	mm
Distance between start or end of shaft and support rail unit and nearest hole	
$a_{L \min}, a_{R \min}$	mm
Minimum values for a_L, a_R according to dimension tables	
$a_{L \max}, a_{R \max}$	mm
Maximum values for a_L, a_R according to dimension tables	
l	mm
Length of shaft and support rail unit	
n	mm
Maximum possible number of pitches or recommended distance between screws on shaft and support rail units with T-slots	
j_L	mm
Distance between holes	
x	mm
Number of holes on shaft and support rail units with T-slots: number of screws.	

Attention!

If the minimum and maximum values for a_L and a_R are not observed, the counterbores of the holes may be intersected. The position a_L for shaft and support rail units TSSW and TSUW is shown in *Figure 4*.



Shaft and support rail units

Accuracy Length tolerances for shafts and shaft and support rail units

The length tolerances are shown in the table.

Tolerances

Length of shaft or shaft and support rail unit L mm Single-piece and multi-piece and shaft support rail units	Length tolerance mm $\pm 0,1$ % of total length
$L \leq 400$	$\pm 0,5$
$400 < L \leq 1\,000$	$\pm 0,8$
$1\,000 < L \leq 2\,000$	$\pm 1,2$
$2\,000 < L \leq 4\,000$	± 2
$4\,000 < L \leq 6\,000$	± 3

Ordering example, ordering designation Shaft and support rail unit

Type	TSNW
Shaft diameter d_{LW}	25
Length	1253
Pitch a_L	26
Pitch a_R	27
Corrosion-resistant design	Available by agreement

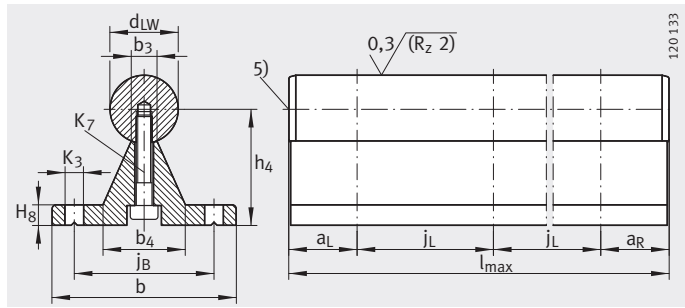
Ordering designation

TSNW25-1253-26-27

Possible ordering designation for standard shaft and support rail units

Type	TSWW, TSNW, TSSW, TSUW, TSWWA
Shaft diameter d_{LW}	12 to 50
Length	1200
Pitch a_L	Start of shaft – first hole
Pitch a_R	Last hole – end of shaft
Corrosion-resistant design	Available by agreement

Shaft and support rail units



TSWW, TSNW

120 133

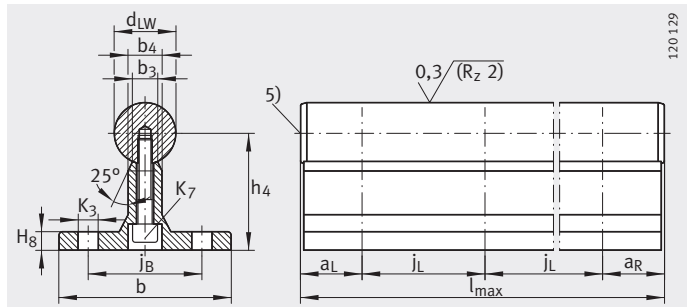
Dimension table · Dimensions in mm

Designation	Mass m ≈g/m	Dimensions				Mounting dimensions									
		d _{LW} h6	b	h ₄ ¹⁾ ±0,02	l _{max} ²⁾ ±3	b ₃	b ₄	j _B	j _L	a _L /a _R ³⁾		H ₈	K ₃ ⁴⁾	K ₇ ISO 4762	
										min.	max.				
TSWW12	1 670	12	40	22	6 000	5	17	29	120	20	114	5	4,5	M4X18	
TSNW12			40	22					75		69				
TSWW16	3 150	16	54	32	6 000	6,8	24,7	41	150	20	143	6	5,5	M5X25	
TSNW16	2 950		45	26					100		93				5
TSWW20	4 030	20	54	34,02	6 000	7,8	24,7	41	150	20	143	6	5,5	M5X25	
TSNW20	3 950		52	32					100		92				6
TSWW25	5 900	25	65	39,66	6 000	9,3	30,3	51	150	20	142	6	6,6	M6X30	
TSNW25	5 600		57	36					120		110				6
TSWW30	7 580	30	65	42,19	6 000	9,3	30,3	51	150	20	142	6	6,6	M6X30	
TSNW30	7 880		69	42					150		139				7
TSWW40	14 250	40	85	60	6 000	16,3	46	65	150	20	139	10	9	M10X45	
TSNW40	12 830		73	50					200		189				8
TSWW50	19 750	50	85	65,06	6 000	16,3	46	65	150	20	139	10	9	M10X45	
TSNW50	19 380		84	60					200		188				9

- 1) In relation to the nominal shaft diameter, measured whilst clamped.
- 2) Maximum length of single-piece shaft and support rail units; longer shaft and support rail units see page 147. Depending on the length of the shaft and support rail unit, the support rail is composed of several individual sections.
- 3) Dimensions a_L/a_R are dependent on the length of the shaft and support rail unit. Calculation see page 149.
- 4) TSWW: For fixing screws ISO 4 762 or ISO 4 017 (TSWW12, DIN 7 984). TSNW: For fixing screws DIN 7 984. If there is a possibility of settling, the screws should be secured against rotation.
- 5) The shaft protrudes on both sides beyond the support rail by approx. 2 mm.



Shaft and support rail units



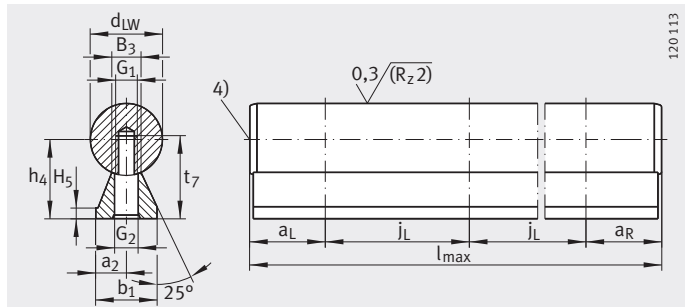
TSWWA

Dimension table - Dimensions in mm

Designation	Mass m ≈g/m	Dimensions				Mounting dimensions								
		d _{LW} h ₆	b	h ₄ ¹⁾ ±0,02	l _{max} ²⁾ ±3	b ₃	b ₄	j _B	j _L	a _L /a _R ³⁾		H ₈	K ₃ ⁴⁾	K ₇ ISO 4762
										min.	max.			
TSWWA12	1 930	12	43	28	6 000	5,4	9	29	75	20	69	5	4,5	M4X25 ⁶⁾
TSWWA16	2 800	16	48	30	6 000	7	10	33	100	20	93	5	5,5	M5X25
TSWWA20	4 120	20	56	38	6 000	8,2	11	37	100	20	92	6	6,6	M6X30
TSWWA25	5 830	25	60	42	6 000	10,4	14	42	120	20	110	6	6,6	M8X30
TSWWA30	8 500	30	74	53	6 000	11	14	51	150	20	139	8	9	M10X40
TSWWA40	13 330	40	78	60	6 000	15	18	55	200	20	189	8	9	M10X45
TSWWA50	20 330	50	90	75	6 000	19	22	63	200	20	188	10	11	M12X50

- 1) In relation to the nominal shaft diameter, measured whilst clamped.
- 2) Maximum length of single-piece shaft and support rail units; longer shaft and support rail units see page 147. Depending on the length of the shaft and support rail unit, the support rail is composed of several individual sections.
- 3) Dimensions a_L/a_R are dependent on the length of the shaft and support rail unit. Calculation see page 149.
- 4) For fixing screws ISO 4 762 or ISO 4 017. If there is a possibility of settling, the fixing screws should be secured against rotation.
- 5) The shaft protrudes on both sides beyond the support rail by approx. 2 mm.
- 6) Screws DIN 7 984.

Shaft and support rail units



TSUW

120 113

Dimension table · Dimensions in mm

Designation	Mass m ≈g/m	Dimensions				Mounting dimensions								
		d _{LW} h ₆	b ₁	h ₄ ¹⁾ ±0,02	l _{max} ²⁾ ±3	a ₂	B ₃	j _L	a _L /a _R ³⁾		H ₅	G ₁	G ₂	t ₇
									min.	max.				
TSUW12	1 100	12	11	14,5	6 000	5,5	5	75	20	70	3	M4	4,5	15,5
TSUW16	1 880	16	14	18	6 000	7	6,8	75	20	70	3	M5	5,5	19
TSUW20	2 920	20	17	22	6 000	8,5	7,8	75	20	69	3	M6	6,6	23
TSUW25	4 420	25	21	26	6 000	10,5	9,8	75	20	68	3	M8	9	28,5
TSUW30	6 220	30	23	30	6 000	11,5	11	100	20	92	3	M10	11	31,5
TSUW40	11 030	40	30	39	6 000	15	14,5	100	20	91	4	M12	13,5	39,5
TSUW50	16 980	50	35	46	6 000	17,5	18,5	100	20	90	5	M14	15,5	46

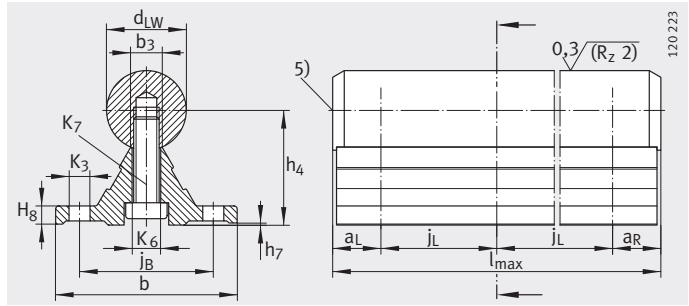
Attention!

The shaft and support rail are supplied unassembled.

- 1) In relation to the nominal shaft diameter, measured whilst clamped.
- 2) Maximum length of single-piece shaft and support rail units; longer shaft and support rail units see page 147. Depending on the length of the shaft and support rail unit, the support rail is composed of several individual sections.
- 3) Dimensions a_L/a_R are dependent on the length of the shaft and support rail unit. Calculation see page 149.
- 4) The shaft protrudes on both sides beyond the support rail by approx. 2 mm.



Shaft and support rail units



TSNW..-G4, TSNW..-G5

Dimension table - Dimensions in mm

Designation	Mass m ≈g/m	Dimensions				Mounting dimensions		
		d _{LW}	b	h ₄ ¹⁾	l _{max} ²⁾	b ₃	j _B	j _L
TSNW12-G4	1 600	12	40	22±0,1	4 000	5	29	75
TSNW16-G4	2 500	16	45	26±0,1	4 000	6,8	33	100
TSNW20-G4	3 800	20	52	32±0,1	4 000	7,8	37	100
TSNW25-G4	5 300	25	57	36±0,1	4 000	9,8	42	120
TSNW30-G5	7 500	30	69	42±0,15	4 000	11	51	150
TSNW40-G5	12 400	40	73	50±0,15	4 000	14,5	55	200
TSNW50-G5	18 900	50	84	60±0,15	4 000	18,5	63	200

1) In relation to the nominal shaft diameter, measured whilst clamped.

2) Maximum length of single-piece shaft and support rail units.

3) Dimensions a_L/a_R are dependent on the length of the shaft and support rail unit. Calculation see page 149.

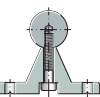
4) For fixing screws DIN 7 964.

If there is a possibility of settling, the screws should be secured against rotation.

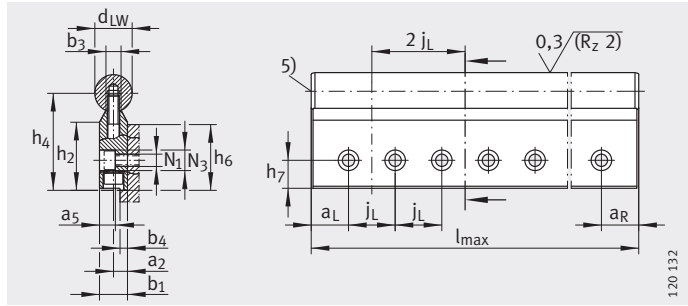
5) The shaft protrudes on both sides beyond the support rail by approx. 2 mm.

6) Maximum variation of dimension h₄, measured on the same shaft and support rail unit over a length of 1 000 mm.

a _L /a _R ³⁾		H ₈	h ₇	K ₃ ⁴⁾	K ₆	K ₇	Deviation from h ₄ ⁶⁾	
							Accuracy class	Variation mm
min.	max.					ISO 4762		
20	69	5	0,2	4,5	4,5	M4X18	G4	0,03
20	93	5	0,2	5,5	5,5	M5X22	G4	0,03
20	92	6	0,2	6,6	6,6	M6X25	G4	0,03
20	110	6	0,3	6,6	9	M8X30	G4	0,03
20	139	7	0,3	9	11	M10X30	G5	0,04
20	189	8	0,3	9	11	M10X35	G5	0,04
20	188	9	0,3	11	13,5	M12X45	G5	0,04



Shaft and support rail units



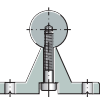
TSSW

Dimension table - Dimensions in mm

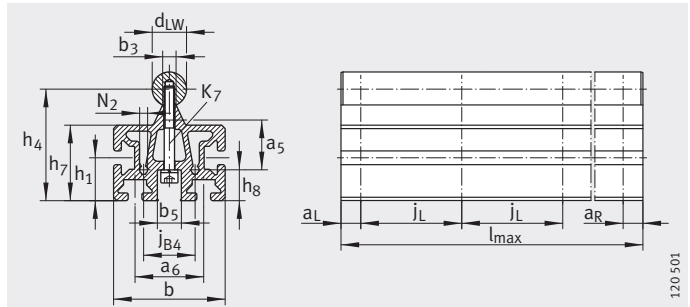
Designation	Mass m ≈g/m	Dimensions				Mounting dimensions				
		d _{LW} h ₆	b ₁	h ₄ ¹⁾ ±0,01	l _{max} ²⁾ ±3	a ₂ ¹⁾ ±0,012	b ₃	b ₄	a ₅ ⁴⁾	j _L
TSSW20	4 120	20	15	52	6 000	7,5	7,8	4,5	8,7	50
TSSW25	5 980	25	20	62	6 000	10	9,8	6	11,2	60
TSSW30	8 680	30	25	72	6 000	12,5	11	7,5	13,7	75
TSSW40	14 300	40	30	88	6 000	15	14,5	9	16,2	100
TSSW50	21 470	50	35	105	6 000	17,5	18,5	9,5	18,7	100

- 1) In relation to the nominal shaft diameter, measured whilst clamped.
- 2) Maximum length of single-piece shaft and support rail units; longer shaft and support rail units see page 147.
Depending on the length of the shaft and support rail unit, the support rail is composed of several individual sections.
- 3) Dimensions a_L/a_R are dependent on the length of the shaft and support rail unit.
Calculation see page 149.
- 4) For fixing screws ISO 4 762-8.8.
If there is a possibility of settling, the screws should be secured against rotation.
- 5) The shaft protrudes on both sides beyond the support rail by approx. 2 mm.

a _L /a _R ³⁾		h ₂	h ₆	h ₇ ±0,15	N ₁ ⁴⁾	N ₃ ⁴⁾
min.	max.					
20	42	35	30	15	6,6	11
20	50	39,5	36	18	9	15
20	64	43	42	21	11	18
20	88	53	50	25	13,5	20
20	86	64	60	30	15,5	24



Shaft and support rail units



TSMW

120 501

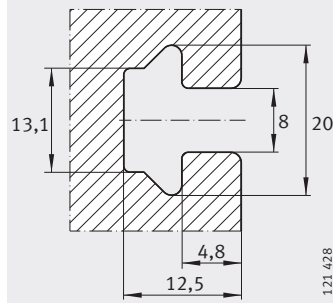
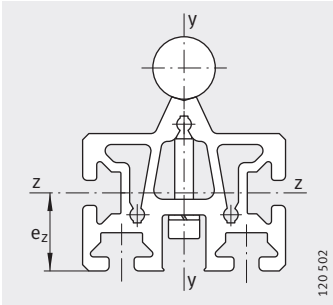
Dimension table - Dimensions in mm

Designation	Mass m	Dimensions				Mounting dimensions												
		d _{LW}	b	h ₄ ¹⁾	l _{max} ²⁾	b ₃	j _{B4}	b ₅	a ₆	j _L	a _L /a _R ³⁾		h ₁	a ₅	h ₇	h ₈	N ₂	K ₇
		≈g/m	h6	±0,2	±3						min.	max.						
TSMW20	6 300	20	65	65	6 000	7,8	30	14	40	75	20	42	25	29	44	18	4,65	M6
TSMW25	8 900	25	75	75	6 000	10	40	18	45	75	20	50	25	34	47	18	4,65	M8
TSMW30	12 300	30	90	90	6 000	11	50	32	60	100	20	64	25	43	57	20	5,5	M10

¹⁾ In relation to the nominal shaft diameter, measured whilst clamped.

²⁾ Maximum length of single-piece shaft and support rail units; longer shaft and support rail units see page 147.
Depending on the length of the shaft and support rail unit, the support rail is composed of several individual sections.

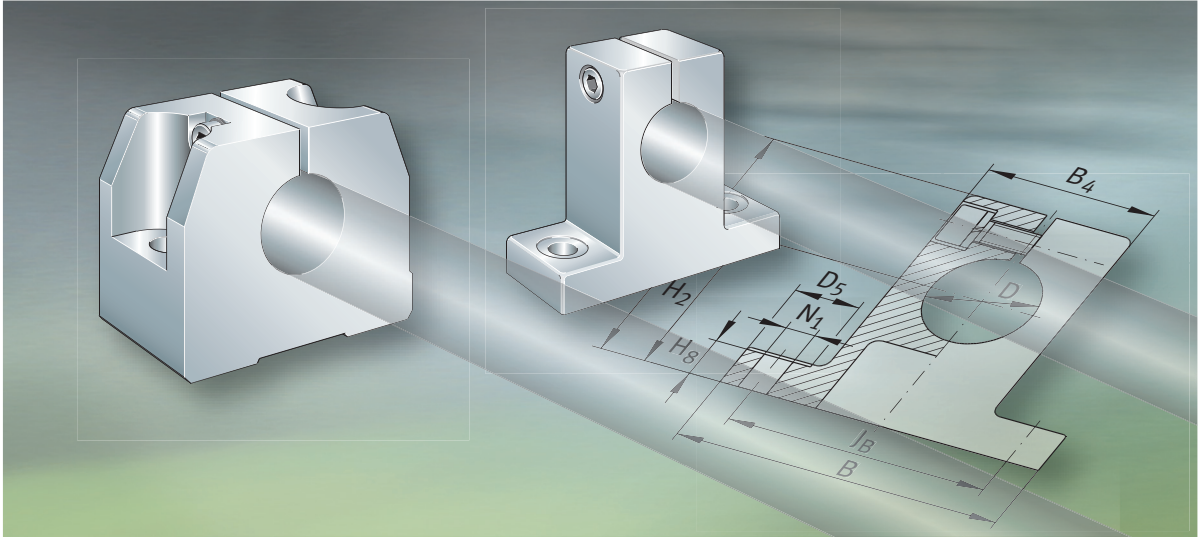
³⁾ Dimensions a_L/a_R are dependent on the length of the shaft and support rail unit.
Calculation see page 149.



TSMW

Modulus of elasticity N/mm ²	Surface data					
	Cross-sectional area mm ²	Bending axis				
		y-y		z-z		
		I_y mm ⁴	W_y mm ³	e_z mm	I_z mm ⁴	W_z mm ³
72 000	1 426	310 500	9 700	25	545 000	21 800
72 000	1 837	528 800	14 000	27,4	925 000	33 800
72 000	2 543	1 050 000	23 500	32,8	1 810 000	55 200





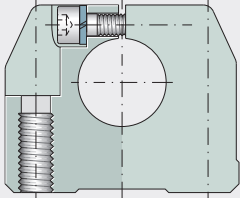
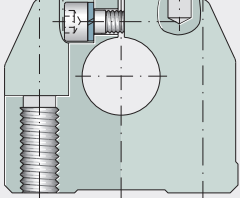
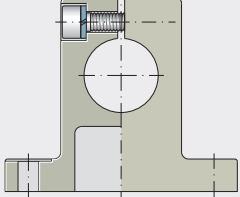
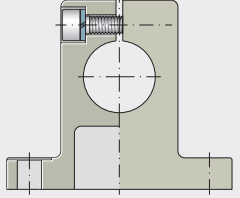
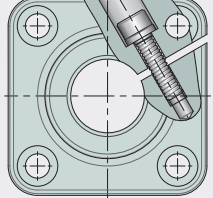
Shaft support blocks

Shaft support blocks

	Page
Matrix Matrix for preselection of shaft support blocks	162
Product overview Shaft support blocks	164
Features	165
Dimension tables Shaft support blocks	166
Shaft support block with flange	170



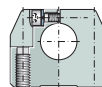
**Matrix for preselection
of shaft support blocks**

Shaft support blocks	Material
<p>GWH</p>  <p>120 523</p>	Aluminium
<p>GWN</p>  <p>120 524</p>	Aluminium
<p>GW</p>  <p>120 525</p>	Pressure diecast zinc
<p>GWA</p>  <p>120 583</p>	Pressure diecast zinc
<p>FW</p>  <p>120 596</p>	Aluminium

Definition:

- Available for stated shaft diameter d_{LW}

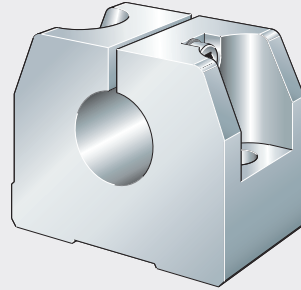
For shaft diameter d_{LW}											Features	Location		Description
												Threaded hole	Through hole	
06	08	10	12	14	16	20	25	30	40	50			Page	
●	●	●	●	●	●	●	●	●	●	●	– Low position of shaft	yes	yes	165
–	–	–	●	–	●	●	●	●	●	●	– Suitable for dowelling	yes	yes	165
–	–	●	●	–	●	●	●	●	●	●	– Space-saving design	–	yes	165
–	–	●	●	–	●	●	●	●	●	●	– For larger fixing screws – Space-saving design	–	yes	165
–	–	–	●	–	●	●	●	●	●	●	– Suitable for dowelling	yes	yes	165



Product overview Shaft support blocks

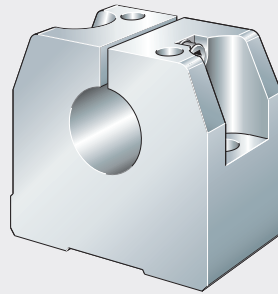
Shaft support blocks

GWH



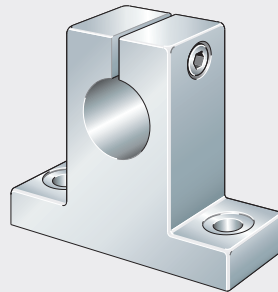
120 461

GWN



120 462

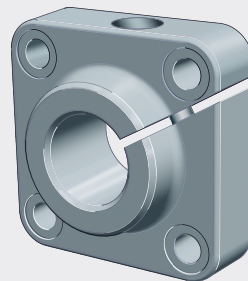
GW, GWA



120 460

Shaft support block with flange

FW



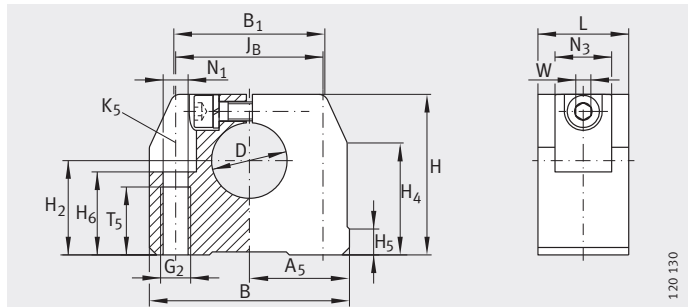
120 597

Shaft support blocks

- Features** Shaft support blocks are used to support shafts and locate the ends of the shaft.
- They are suitable for all the solid and hollow shafts in this catalogue.
- They are made from either an aluminium alloy or pressure diecast zinc.
- Series GWA is identical in design to series GW but is suitable for larger fixing screws.
- Depending on the series, the shaft support blocks have through holes or threaded holes.



Shaft support blocks



GWH

120 130

Dimension table - Dimensions in mm

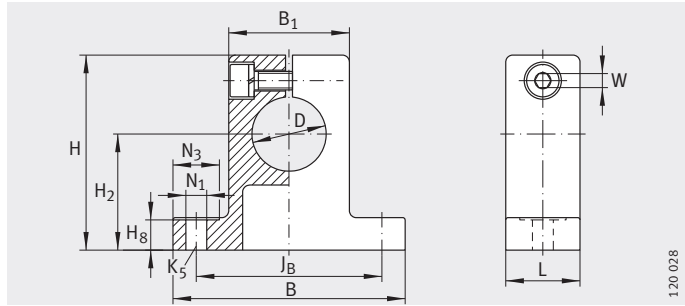
Designation	Mass m ≈g	Dimensions				Mounting dimensions												
		D H8	B	L	H	JB ±0,15	A5	B1	H2 ±0,01	H4	H5	T5	H6	G2	N1	N3	K5 ¹⁾	W ²⁾
GWH06	30	6	32	16	27	22	16	25	15	20,6	5	11	13	M5	4,3	10	M4	2,5
GWH08	30	8	32	16	27	22	16	25	16	20,6	5	11	13	M5	4,3	10	M4	2,5
GWH10	50	10	40	18	33	27	20	32	18	25,1	5	13	16	M6	5,3	11	M5	3
GWH12	50	12	40	18	33	27	20	32	19	25,1	5	13	16	M6	5,3	11	M5	3
GWH14	70	14	43	20	36,5	32	21,5	34	20	28,1	6,9	13	18	M6	5,3	11	M5	3
GWH16	70	16	43	20	36,5	32	21,5	34	22	28,1	6,9	13	22	M6	5,3	11	M5	3
GWH20	120	20	53	24	42,5	39	26,5	40	25	29,8	7,4	18	22	M8	6,6	15	M6	4
GWH25	170	25	60	28	52,5	44	30	44	31	36,6	9,9	22	26	M10	8,4	18	M8	5
GWH30	220	30	67	30	60	49	33,5	49,5	34	42,7	8	22	29	M10	8,4	18	M8	5
GWH40	480	40	87	40	73,5	66	43,5	63	42	49,7	12,8	26	38	M12	10,5	20	M10	6
GWH50	820	50	103	50	92	80	51,5	74	50	62,3	10,9	34	46	M16	13,5	24	M12	8

¹⁾ For fixing screws ISO 4 762-8.8.

If there is a possibility of settling, the screws should be secured against rotation.

²⁾ Width across flats.

Shaft support blocks



GW, GWA

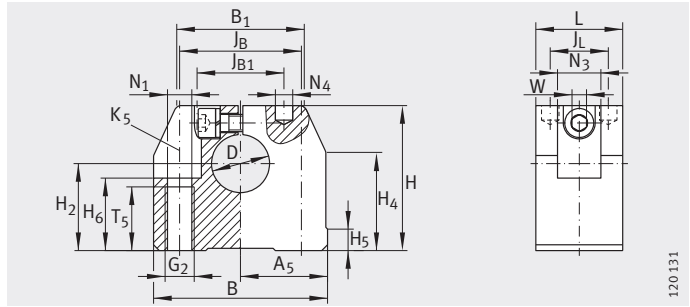
Dimension table · Dimensions in mm

Designation	Mass m ≈g	Dimensions				Mounting dimensions							
		D	B	L	H	J _B	B ₁	H ₂	H ₈	N ₁ ¹⁾	N ₃	K ₅	Width across flats W
GW10	30	10	37	11	30	28 ±0,15	18	17	5	3,4	8	M3	2,5
GWA10										4,5	9	M4	
GW12	40	12	42	12	35	32 ±0,15	20	20	5,5	4,5	10	M5	3
GWA12										5,5	11	M4	
GW14	60	14	46	14	38	36 ±0,15	23	22	6	4,5	10	M5	3
GWA14										5,5	11	M4	
GW16	80	16	50	16	42	40 ±0,15	26	25	6,5	4,5	10	M5	3
GWA16										5,5	11	M4	
GW20	150	20	60	20	50	45 ±0,15	32	30	7,5	4,5	10	M5	3
GWA20										5,5	11	M4	
GW25	260	25	74	25	58	60 ±0,15	38	35	8,5	5,5	11	M5	4
GWA25										6,6	13	M6	
GW30	380	30	84	28	68	68 ±0,2	45	40	9,5	6,6	13	M6	5
GWA30										9	18	M8	
GW40	670	40	108	32	86	86 ±0,2	56	50	12	9	18	M8	6
GWA40										11	22	M10	
GW50	1380	50	130	40	100	108 ±0,2	80	60	14	9	18	M8	6
GWA50										11	22	M10	

¹⁾ For fixing screws ISO 4 762-8.8.
If there is a possibility of settling, the screws should be secured against rotation.



Shaft support blocks



GWN

Dimension table - Dimensions in mm

Designation	Mass m ≈g	Dimensions				Mounting dimensions				
		D H8	B	L	H	JB	JB1	B1	A5 ±0,01	JL
GWN12	60	12	43	20	35	30 ±0,15	20	34	21,5	13
GWN16	100	16	53	24	42	38 ±0,15	26	40	26,5	16
GWN20	170	20	60	30	50	42 ±0,15	30	44	30	20
GWN25	330	25	78	38	60	56 ±0,15	40	60	39	25
GWN30	450	30	87	40	70	64 ±0,15	45	63	43,5	26
GWN40	850	40	108	48	90	82 ±0,15	65	76	54	32
GWN50	1 400	50	132	58	105	100 ±0,2	70	90	66	36

1) For fixing screws ISO 4 762-8.8.

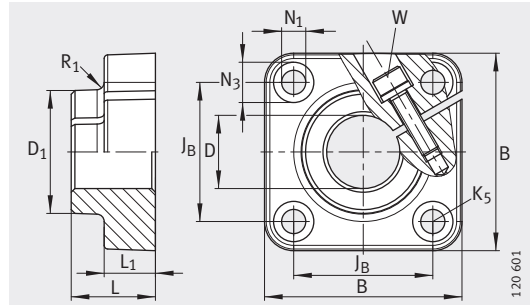
If there is a possibility of settling, the screws should be secured against rotation.

2) Centring for dowel hole.

H ₂ ±0,01	H ₄	H ₅	T ₅	H ₆	G ₂	N ₁	N ₄ ²⁾	N ₃	K ₅ ¹⁾	Width across flats W
20	26,6	5,4	13	16,5	M6	5,3	4	10	M5	3
25	26,6	5,4	18	21	M8	6,6	5	11	M6	4
30	34,1	7,4	22	25	M10	8,4	6	15	M8	5
35	41,5	8,3	26	30	M12	10,5	8	18	M10	6
40	46,2	9,3	26	34	M12	10,5	8	18	M10	6
50	57,6	11,7	34	44	M16	13,5	10	20	M12	8
60	62	10,6	43	49	M20	17,5	12	26	M16	10



Shaft support block with flange



FW

Dimension table - Dimensions in mm

Designation	Mass m ≈g	Dimensions			Mounting dimensions							
		D H8	B	L	L ₁	D ₁	N ₁	N ₃	K ₅ ¹⁾	R ₁	J _B	Width across flats W
FW12	60	12	42	20	12	23,5	5,5	10	M5	2	30	3
FW16	80	16	50	20	12	27,5	5,5	10	M5	2	35	3
FW20	110	20	54	23	14	33,5	6,6	11	M6	2	38	4
FW25	150	25	60	25	16	42	6,6	11	M6	2	42	5
FW30	290	30	76	30	19	49,5	9	15	M8	5	54	6
FW40	610	40	96	40	26	65	11	18	M10	5	68	8
FW50	970	50	106	50	36	75	11	18	M10	5	75	8

¹⁾ For fixing screws ISO 4 762-8.8.
If there is a possibility of settling, the screws should be secured against rotation.

Addresses

- Germany** Schaeffler KG
Linear Technology Division
Berliner Straße 134
66424 Homburg (Saar)
Tel. +49 6841 701-0
Fax +49 6841 701-2625
info.linear@schaeffler.com
- Argentina** Schaeffler Argentina S.r.l.
Av. Alvarez Jonte 1938
Buenos Aires C1416EXR
Tel. +54 11 40 16 15 00
Fax +54 11 45 82 33 20
info-ar@schaeffler.com
- Australia** Schaeffler Australia Pty Ltd.
Level 1, Bldg. 8,
49 Frenchs Forest Road
Frenchs Forest, NSW 2086
Tel. +61 2 8977 1000
Fax +61 2 9452 4242
info.au@schaeffler.com
- Austria** Schaeffler Austria GmbH
Marktstraße 5
2331 Vösendorf
Tel. +43 1 69 92 54 10
Fax +43 1 6 99 25 41 55
info.at@schaeffler.com
- Belarus** Schaeffler KG Repräsentanz Weißrußland
Representative Office Ukraine
4-yj Zagorodnyi per. - 58-B
220079 Minsk
Tel. +375 17-204 11 49
Fax +375 17-210 24 18
fagminsk@mail.bn.by
- Belgium** Schaeffler Belgium S.P.R.L.
Avenue du Commerce, 38
1420 Braine L'Alleud
Tel. +32 2 3 89 13 89
Fax +32 2 3 89 13 99
info.be@schaeffler.com
- Bosnia and Herzegovina** Valjkasti Lezajevi d.o.o.
Domobranska 11
10000 Zagreb
Croatia
Tel. +385 1 37 01 943
Fax +385 1 37 64 473
fag@fag.hr
- Brazil** Schaeffler Brasil Ltda.
Av. Independência, 3500-A
Bairro Éden
Sorocaba SP 18087-101
Tel. +55 15 33 35 15 00
Fax +55 15 33 35 19 60
info.br@schaeffler.com
- Bulgaria** Schaeffler Bulgaria OOD
Boul. Knjaz Alexander Dondukov
No 62 Eing. A, 6. Etage, App. 10
1504 Sofia
Tel. +359 2 946 3900
+359 2 943 4008
Fax +359 2 943 4134
info.bg@schaeffler.com



Addresses

- Canada** Schaeffler Canada Inc.
2871 Plymouth Drive
Oakville, ON L6H 5S5
Tel. +1 800 263 4397 (Toll Free)
Tel. +1 905 8 29 27 50
Fax +1 905 8 29 25 63
info.ca@schaeffler.com
- China** Beijing Representative Office
Room 708-711, Scitech Tower No. 22
Jianguomenwai Avenue
100004 Beijing
Tel. +86 10 6515 0288
Fax +86 10 6512 3433
l.huang@schaeffler.com
- Croatia** Schaeffler Hrvatska d.o.o.
Domobranska 11
10000 Zagreb
Tel. +385 1 37 01 943
Fax +385 1 37 64 473
info.hr@schaeffler.com
- Czech Republic** Schaeffler CZ s.r.o.
Prubezná 74a
100 00 Praha 10
Tel. +420 267 298 111
Fax +420 267 298 110
info.cz@schaeffler.com
- Denmark** Schaeffler Danmark ApS
Jens Baggesens Vej 90P
8200 Aarhus N
Tel. +45 70 15 44 44
Fax +45 70 15 22 02
info.dk@schaeffler.com
- Estonia** Schaeffler KG Repräsentanz Baltikum
K. Ulmana gatve 119
2167 Riga
Latvia
Tel. +371 7 06 37 95
Fax +371 7 06 37 96
info.lv@schaeffler.com
- Finland** Schaeffler Finland Oy
Lautamiehentie 3
02770 Espoo
Tel. +358 207 36 6204
Fax +358 207 36 6205
info.fi@schaeffler.com
- France** Schaeffler France SAS
44-48, rue Louveau - BP 91
92323 Chatillon
Tel. +33 140 92 16 16
Fax +33 140 92 87 57
info.fr@schaeffler.com
- Schaeffler France SAS
93, route de Bitche, BP 30186
67506 Haguenau
Tel. +33 3 88 63 40 40
Fax +33 3 88 63 40 41
info.fr@schaeffler.com
- Great Britain** Schaeffler (UK) Ltd
Forge Lane, Minworth
Sutton Coldfield B76 1AP
Tel. +44 121 / 3 51 38 33
Fax +44 121 / 3 51 76 86
info.uk@schaeffler.com
- Schaeffler (UK) Ltd
Bynea
CARMS SA14 9TG Llanelli
Tel. +44 15 54 / 77 22 88
Fax +44 15 54 / 77 12 01
info.uk@schaeffler.com
- Schaeffler (UK) Ltd
Plymbridge Road - Estover
Plymouth PL6 7LH
Tel. +44 1752 73 55 55
Fax +44 1752 73 34 81
sales@barden.co.uk
- Hungary** Schaeffler Magyarország Ipari Kft.
Neuman János út 1/B fsz.
1117 Budapest
Tel. +36 1 / 4 81 30 50
Fax +36 1 / 4 81 30 53
budapest@schaeffler.com
- Italy** Schaeffler Italia S.r.l.
Strada Regionale 229 Km. 17
28015 Momo (Novara)
Tel. 0321 929211
Fax 0321 929300
info.it@schaeffler.com

- Japan** Schaeffler Japan Co., Ltd.
Square Building 18F
2-3-12 Shin-Yokohama, Kohoku-ku
Yokohama, 222-0033
Tel. +81 45 476 5900
Fax +81 45 476 5920
info.jp@schaeffler.com
- Korea** Schaeffler Ansan Corporation
1054-2 Shingil-dong
Ansan-shi
Kyonggi-do, 425-020
Tel. +82 31 490 6911
Fax +82 31 494 3888
info.kr@schaeffler.com
- Latvia** Schaeffler KG Repräsentanz Baltikum
K. Ulmana gatve 119
2167 Riga
Tel. +371 7 06 37 95
Fax +371 7 06 37 96
info.lv@schaeffler.com
- Lithuania** Schaeffler KG Repräsentanz Baltikum
K. Ulmana gatve 119
2167 Riga
Latvia
Tel. +371 7 06 37 95
Fax +371 7 06 37 96
info.lv@schaeffler.com
- Mexico** INA Mexico, S.A. de C.V.
Paseo de la Reforma 383, int. 704
Col. Cuahatemoc
Mexico D.F. 06500
Tel. +52 55 55 25 00 12
Fax +52 55 55 25 01 94
info.mx@schaeffler.com
- Netherlands** Schaeffler Nederland B.V.
Gildeweg 31
3771 NB Barneveld
Tel. +31 342 40 30 00
Fax +31 342 40 32 80
info.nl@schaeffler.com
- New Zealand** Schaeffler New Zealand
(Unit R, Cain Commercial Centre) 20 Cain
Road
1642 Penrose
Tel. +54 11 40 16 15 00
Fax +54 11 45 82 33 20
sales.nz@schaeffler.com
- Norway** Schaeffler Norge AS
Nils Hansens Vei 2
0667 Oslo
Tel. +47 23 24 93 30
Fax +47 23 24 93 31
info.no@schaeffler.com
- Poland** Schaeffler Polska
Budynek E
ul. Szyszkowa 35/37
02-285 Warszawa
Tel. +48 22 8 78 41 20
Fax +48 22 8 78 41 22
info.pl@schaeffler.com
- Portugal** INA Rolamentos Lda.
Av. Fontes Pereira de Melo, 470
4149-012 Porto
Tel. +351 22 / 5 32 08 00
Fax +351 22 / 5 32 08 60
marketing.pt@schaeffler.com
- Romania** S.C. Schaeffler Romania S.R.L.
Aleea Schaeffler Nr. 3
Cristian/Brasov 507055
Tel. +40 268 505808
Fax +40 268 505848
info.se@schaeffler.com
- Russia** Schaeffler Rußland GmbH
Ul. Tjuschina 4-6
191 119 St. Petersburg
Tel. +7 812 325 22 92
Fax +7 812 325 22 93
fag@fag.spb.ru

Schaeffler Rußland
Korp. 14
Leningradsky Prospekt 37A
125167 Moscow
Tel. +7 95 7 37 76 60
Fax +7 95 7 37 76 53
info.ru@schaeffler.com
- Serbia** Schaeffler KG Repräsentanz Serbien
Branka Krsmanovica 12
11118 Beograd
Tel. +381 11 308 87 82
Fax +381 11 308 87 75
fagbgdyu@sezampro.yu



Addresses

- Singapore** Schaeffler (Singapore) Pte. Ltd.
151 Lorong Chuan, #06-01
New Tech Park, Lobby A
556741 Singapore
Tel. +65 6540 8600
Fax +65 6540 8668
info.sg@schaeffler.com
- Slovakia** Schaeffler Slovensko, spol. s.r.o.
Ulica Dr. G. Schaefflera
024 01 Kysucké Nové Mesto
Tel. +421 41 4 20 59 11
Fax +421 41 4 20 59 18
info.sk@schaeffler.com
- INA Kysuce, a.s.
Ulica Dr. G. Schaefflera
02401 Kysucké Nové Mesto
Tel. +421 41 4 20 51 11
Fax +421 41 4 20 59 18
- INA Skalica spol. s.r.o.
Ulica Dr. G. Schaefflera 1
90901 Skalica
Tel. +421 34 6 96 11 11
Fax +421 34 6 64 55 68
- Slovenia** Schaeffler Slovenija
Glavni trg 17/b
2000 Maribor
Tel. +386 2 22 82 070
Fax +386 2 22 82 07 5
info.si@schaeffler.com
- South Africa** Schaeffler South Africa (Pty.) Ltd.
1 End Street Ext. Corner Heidelberg Road
2000 Johannesburg
Tel. +27 11 225 3000
Fax +27 11 334 1755
info.co.za@schaeffler.com
- Spain** Schaeffler Iberia, s.l.
Polígono Ind. Pont Reixat
08960 Sant Just Desvern
Tel. +34 93 / 4 80 34 10
Fax +34 93 / 3 72 92 50
marketing.es@schaeffler.com
- Sweden** Schaeffler Sverige AB
Charles gata 10
195 61 Arlandastad
Tel. +46 8 59 51 09 00
Fax +46 8 59 51 09 60
info.se@schaeffler.com
- Switzerland** HYDREL GmbH
Badstraße 14
8590 Romanshorn
Tel. +41 71 4 66 66 66
Fax +41 71 4 66 63 33
info.ch@schaeffler.com
- Turkey** Schaeffler Rulmanlari Ticaret Limited
Sirketi
Aydin Sokak Dagli Apt. 4/4
1. Levent
34340 Istanbul
Tel. +90 212 / 2 79 27 41
Fax +90 212 / 2 81 66 45
info.tr@schaeffler.com
- Ukraine** Schaeffler KG
Representative Office Ukraine
Ul. Schelkowitzchnaja 16B, of. 29-30
01024 Kiev
Tel. +380 44 253 72 60
Fax +380 44 253 96 42
info.ua@schaeffler.com
- USA** Schaeffler Group USA Inc.
308 Springhill Farm Road
Corporate Offices
Fort Mill, SC 29715
Tel. +1 803 548 8500
Fax +1 803 548 8599
info.us@schaeffler.com

Notes



Notes