

# Torque Limiters

45

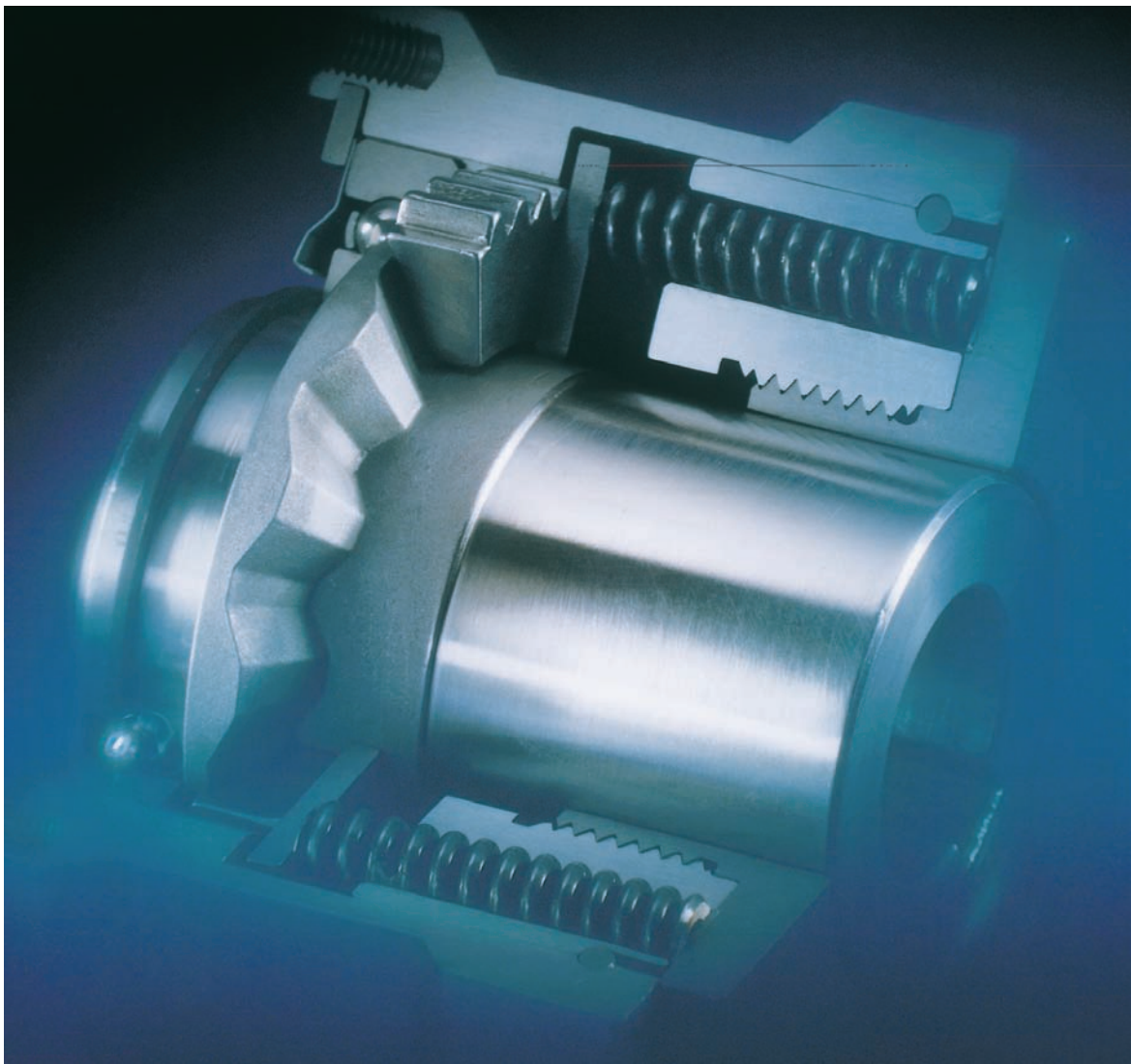

RINGSPANN® Registered Trademark of RINGSPANN GmbH, Bad Homburg

# Index

	Page		Page
<b>Why RINGSPANN Torque Limiters?</b>	<b>3</b>	<b>Synchronous Ratcheting SIKUMAT®- Backlash free with balls</b>	<b>36</b>
<b>Overview RINGSPANN Torque Limiters</b>	<b>4</b>	Series SU - flange design	38
<b>Ratcheting SIKUMAT® with screw faces</b>	<b>6</b>	Series SUG - with long hub	39
Series SC - flange design	8	Series SUE - with flexible shaft coupling	40
Series SCE - with flexible shaft coupling	9	Series SUL - with torsionally rigid shaft coupling	41
Series SCL - with torsionally rigid shaft coupling	10	<b>Disengaging SIKUMAT® with single rollers</b>	<b>42</b>
Proximity switch for Ratcheting SIKUMAT® with screw faces	11	Series SR - flange design	44
<b>Ratcheting SIKUMAT® with balls</b>	<b>12</b>	Series SRR - with short hub and integral needle bearing	45
Series SG - flange design	14	Series SRG - with long hub	46
Series SGR - with short hub and integral needle bearing	15	Series SRE - with flexible shaft coupling	47
Series SGG - with long hub	16	<b>Synchronous Disengaging SIKUMAT® with double rollers</b>	<b>48</b>
Series SGE - with flexible shaft coupling	17	Series SB - flange design	50
<b>Ratcheting SIKUMAT® - Backlash free with balls</b>	<b>18</b>	Series SBG - with long hub	51
Series ST - flange design	20	Series SBE - with flexible shaft coupling	52
Series STG - with long hub	21	Series SBL - with torsionally rigid shaft coupling	53
Series STE - with flexible shaft coupling	22	<b>Non-disengaging SIKUMAT® with single rollers</b>	<b>54</b>
Series STL - with torsionally rigid shaft coupling	23	Series SL - flange design	56
<b>Synchronous Ratcheting SIKUMAT® with single rollers</b>	<b>24</b>	Series SLR - with short hub and integral needle bearings	57
Series SN - flange design	26	Series SLG - with long hub	58
Series SNR - with short hub and integral bearing	27	Series SLE - with flexible shaft coupling	59
Series SNG - with long hub	28	<b>SIKUMAT® Proximity Switch</b>	<b>60</b>
Series SNE - with flexible shaft coupling	29	Non-contact SIKUMAT® Proximity Switch	60
<b>Synchronous Ratcheting SIKUMAT® with double rollers</b>	<b>30</b>	Mechanical SIKUMAT® Proximity Switch	61
Series SA - flange design	32	<b>RIMOSTAT® Torque Limiter</b>	<b>62</b>
Series SAG - with long hub	33	Series RS	63
Series SAE - with flexible shaft coupling	34	Series RS - with chain wheel	64
Series SAL - with torsionally rigid shaft coupling	35	Series RSC - with flexible chain coupling	65
		<b>Belleville Spring Torque Limiter</b>	<b>66</b>
		Series RT	67
		<b>Calculation of RIMOSTAT®-Torque Limiters</b>	<b>68</b>
		<b>Comparison Table of current Torque Limiters</b>	<b>69</b>
		<b>Selection sheet for RINGSPANN Torque Limiters</b>	<b>70</b>

# Why RINGSPANN Torque Limiters?



The more comprehensive the automation of machines and installations, the safer their operational function needs to be. Blockages or overloads should never be cause for the destruction of operationally important components. Stoppages must be kept to a minimum so that the production process continues as quickly as possible and without costly repairs. After all, shorter downtimes mean higher productivity.

RINGSPANN Torque Limiters are mechanical safety devices which disconnect the output from the input when a preset limit value has been reached. Thus they protect against damage and stoppage times caused by overload.

For over 40 years RINGSPANN has manufactured Torque Limiters with an excellent track record in the most diverse applications. Today RINGSPANN offers a comprehensive range of positive and friction Torque Limiters.

Positive SIKUMAT Torque Limiters are used as precision safety devices in installations and machines. The unsurpassed variety of working principles offer optimal solutions to every type of application:

- SIKUMAT with screw faces for particularly heavy-duty operating conditions,
- SIKUMAT with double rollers for high consistency of the limit torque over the duration of the operating period,

- SIKUMAT with balls for very high response accuracy as well as for backlash free transmission of torque and
- SIKUMAT with single rollers for universal application conditions.











Friction Torque Limiters are available in two designs:

- RIMOSTAT Torque Limiters for high torque consistency even during frequent slipping and
- Belleville Spring Torque Limiters for particularly cost effective solutions.

RINGSPANN supplies not only Torque Limiters but can also offer comprehensive advice and service. RINGSPANN provides the security you need.

# Overview RINGSPANN Torque Limiters

		Torque limiting by				Re-engagement			Backlash free	Consistency of torque limiting over operating period				
		ratcheting	dis-engaging	proximity switch	slipping	automatic	automatic synchronously after 360°	manually		manually synchronously after 360°	very high	high	medium	low
Positive locking	<b>Ratcheting SIKUMAT with screw faces</b> Series: SC, SCE and SCL													
	<b>Ratcheting SIKUMAT with balls</b> Series: SG, SGR, SGG and SGE													
	<b>Ratcheting SIKUMAT – Backlash free with balls</b> Series: ST, STG, STE and STL													
	<b>Synchronous Ratcheting SIKUMAT with single rollers</b> Series: SN, SNR, SNG and SNE													
	<b>Synchronous Ratcheting SIKUMAT with double rollers</b> Series: SA, SAG, SAE and SAL													
	<b>Synchronous Ratcheting SIKUMAT – Backlash free with balls</b> Series: SU, SUG, SUE and SUL													
	<b>Disengaging SIKUMAT with single rollers</b> Series: SR, SRR, SRG and SRE													
	<b>Synchronous Disengaging SIKUMAT with double rollers</b> Series: SB, SBG, SBE and SBL													
<b>Locking SIKUMAT with single rollers</b> Series: SL, SLR, SLG and SLE														
Friction locking	<b>RIMOSTAT Torque Limiter</b> Series: RS and RSC													
	<b>Belleville Spring Torque Limiter</b> Series: RT													

Torque range [Nm]				max. shaft Ø [mm]	Speed range [rpm]			Robustness			Page
10	10 <sup>2</sup>	10 <sup>3</sup>	10 <sup>4</sup>		10 <sup>3</sup>	10 <sup>4</sup>	10 <sup>5</sup>	high	medium	low	
6 - 335				45	1 500						6
2,5 - 2 000				65	3 300						12
5 - 740				60	4 000						18
5 - 1 800				65	1 000						24
7 - 10 000				125	1 500						30
5 - 740				60	4 000						36
5 - 1 800				65	5 000						42
8 - 10 000				125	6 000						48
5 - 1 800				65	4 000						54
2 - 6 000				115	13 000						62
0,5 - 10 000				120	1 500						66

# Ratcheting SIKUMAT

## with screw faces

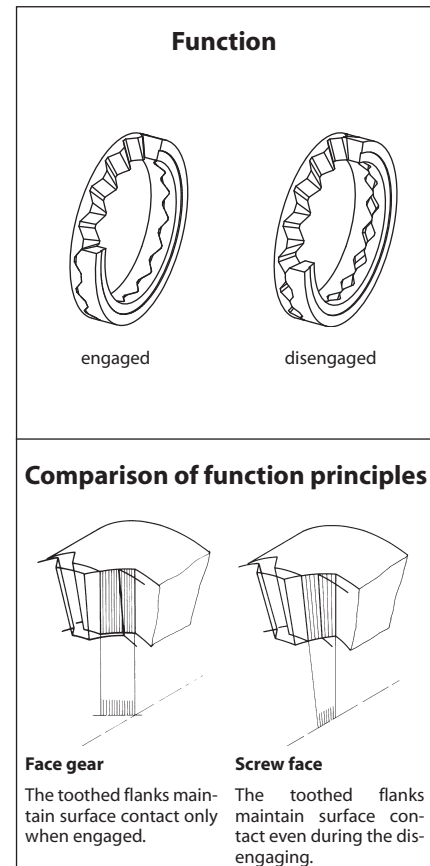

### The Screw Face Principle

Torque transmission is effected through screw-shaped radial serrations in the input and output part, which are pressed together by spring force. Like the thread sides of a screw have edge contact with the nut during turning, so the toothed flanks of the SIKUMAT retain their surface contact even during the torque disengaging process. This characteristic gives the SIKUMAT an extremely high resistance against wear and therefore a long operating life.

### Advantages

- Excellent robustness through surface contact during the disengaging process – therefore maximum life
- Fully enclosed with integral bearing – therefore maintenance-free
- Protection against unauthorised adjustment of the torque setting achieved by the fixed stop of the threaded ring
- Adjustment of limit torque setting according to the number of active springs – not through modification of spring pressure

### Function

- When reaching the preset limit torque the SIKUMAT ratchets.
- After elimination of the overload the SIKUMAT re-engages automatically.
- The overload can be indicated by the special proximity switch for the ratcheting SIKUMAT with screw faces, thus either causing the drive to be switched off instantly or another control function to be activated.

# Ratcheting SIKUMAT with screw faces

## Types

### Series SC - flange design

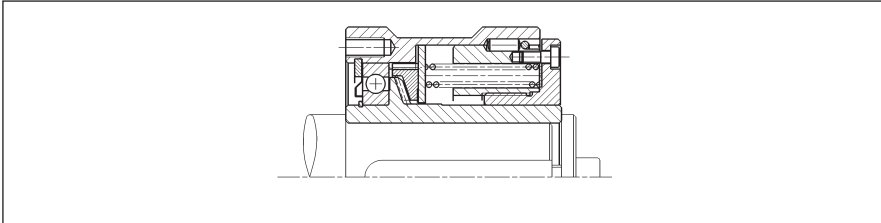

For attaching chain wheels, belt pulleys, gear wheels etc. Bearing of attached component on the shaft to be provided by the customer.

Page 8

### Series SCE - with flexible shaft coupling

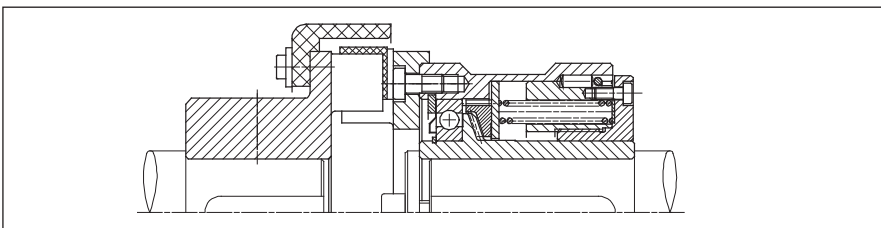

For flexible connection of two shafts. The flexible elements are oil-proof.

Page 9

### Series SCL - with torsionally rigid shaft coupling

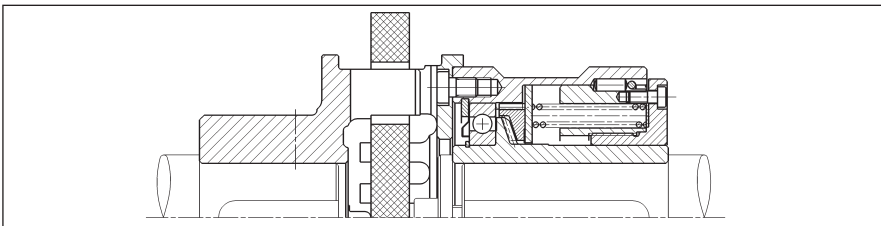

For rigid connection of two shafts. Possibility to compensate for large radial and angular displacements.

Page 10

## Notes

### Torque setting

Normally the limit torque is set at the factory. Setting or modification of the limit torque can be carried out by the customer but no unauthorised adjustment should be made by the machine operator. See operating instructions for further details.

### Proximity switch

The proximity switch for the ratcheting SIKUMAT with screw faces indicates overload by non-contact means with an inductive proximity switch. See page 11 for details.

### Speed Control ESC

The RINGSPANN speed control ESC (Electronic Speed Control) monitors speed deviations and speed differences safely and also under difficult operating conditions. See catalogue 50.1 for details.

# Ratcheting SIKUMAT

## with screw faces

### Series SC - flange design

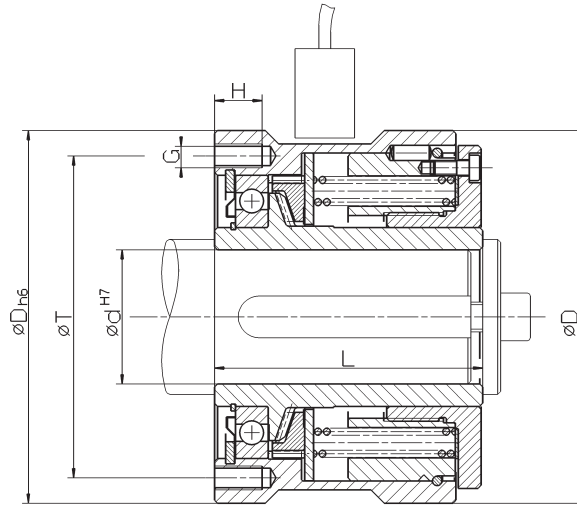

Z = number of tapped holes G on pitch circle T · Installation must be shut down as soon as torque limiter responds

## Technical Data

type	art. no.	torque type 1			torque type 2		
		limit torque Nm	max. speed min <sup>-1</sup>	end no.	limit torque Nm	max. speed min <sup>-1</sup>	end no.
SC 35.x	4472.004.xxx	15 - 85	1500	000	6 - 38	1500	100
SC 45.x	4472.005.xxx	20 - 125	1500	000	9 - 55	1500	100
SC 60.x	4472.006.xxx	45 - 335	1500	000	14 - 100	1500	100

## Dimensions

Type	Référence	bore d			D	G	H	L	T	Z	Course active
		min. mm	max. <sup>1)</sup> mm	max. <sup>2)</sup> mm							
SC 35.x	4472.004.xxx	7	22	25	82	M5	10	56	70	6	1,6
SC 45.x	4472.005.xxx	9	30	32	100	M6	12	71	90	6	2,0
SC 60.x	4472.006.xxx	14	42	45	125	M8	16	90	108	6	2,5

<sup>1)</sup>Keyway as per DIN 6885, page 1

<sup>2)</sup>Keyway as per DIN 6885, page 3

Tolerance of keyway width P9

## Example for Ordering

please indicate when ordering:	type	art. no.	preset limit torque	bore d	with proximity switch
	SC 35. 2	4472.004. 100	7 Nm	12 mm	see page 11

torque type  end no.



# Ratcheting SIKUMAT

with screw faces

Series SCE - with flexible shaft coupling

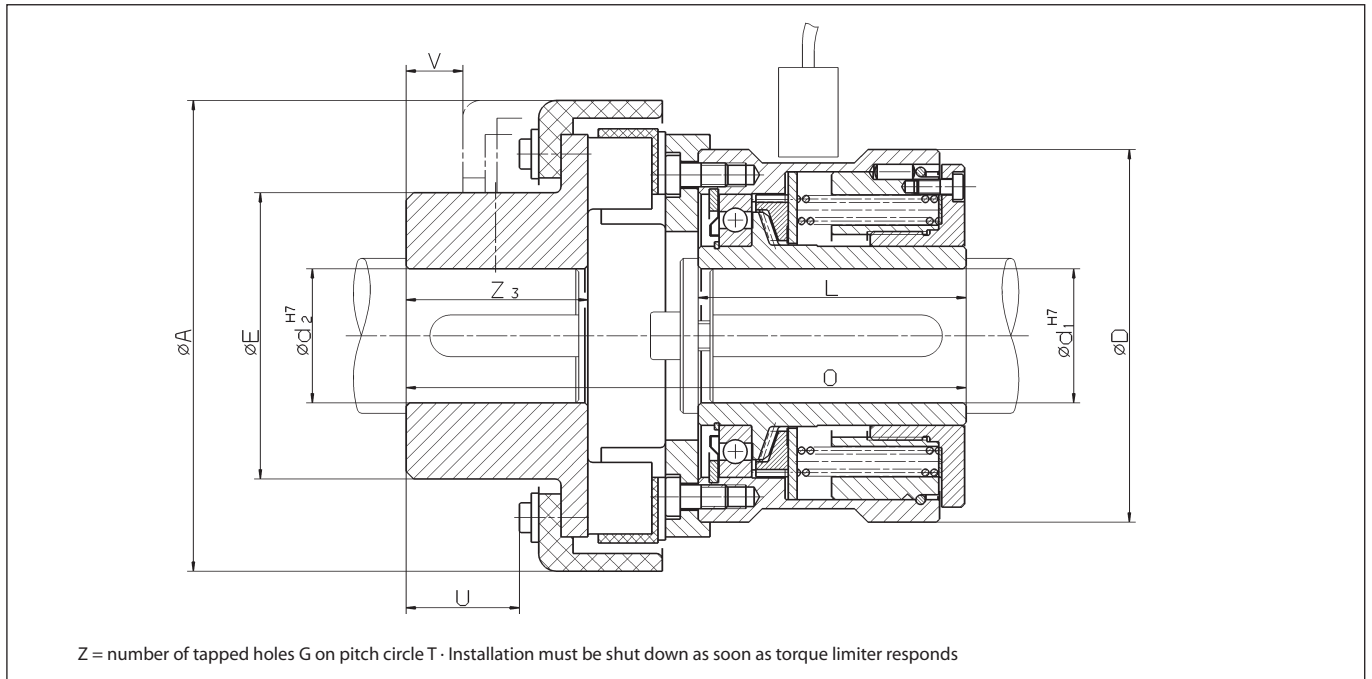

## Technical Data

type	art. no.	torque type 1			torque type 2		
		limit torque Nm	max. speed $\text{min}^{-1}$	end no.	limit torque Nm	max. speed $\text{min}^{-1}$	end no.
SCE 35.x	4472.604.xxx	15 - 85	1500	000	6 - 38	1500	100
SCE 45.x	4472.605.xxx	20 - 125	1500	000	9 - 55	1500	100
SCE 60.x	4472.606.xxx	45 - 335	1500	000	14 - 100	1500	100

## Dimensions

Type	Référence	bore $d_1$			bore $d_2$		A	D	E	L	O	U	V	$Z_3$	Course active
		min. mm	max. <sup>1)</sup> mm	max. <sup>2)</sup> mm	min. mm	max. <sup>1)</sup> mm									
SCE 35.x	4472.604.xxx	7	22	25	10	45	114	82	72	56	131	28	19	48	1,6
SCE 45.x	4472.605.xxx	9	30	32	10	50	127	100	78	71	151	31	20	52	2,0
SCE 60.x	4472.606.xxx	14	42	45	20	60	158	125	96	90	188	39	21	61	2,5

<sup>1)</sup>Keyway as per DIN 6885, page 1

<sup>2)</sup>Keyway as per DIN 6885, page 3

Tolerance of keyway width P9

## Example for Ordering

please indicate when ordering:	type	art. no.	preset limit torque	bore $d_1$	bore $d_2$	with proximity switch
	SCE 35. 2	4472.604. 100	7 Nm	12 mm	15 mm	see page 11

torque type  end no.

# Ratcheting SIKUMAT

with screw faces

Series SCL - with torsionally rigid shaft coupling

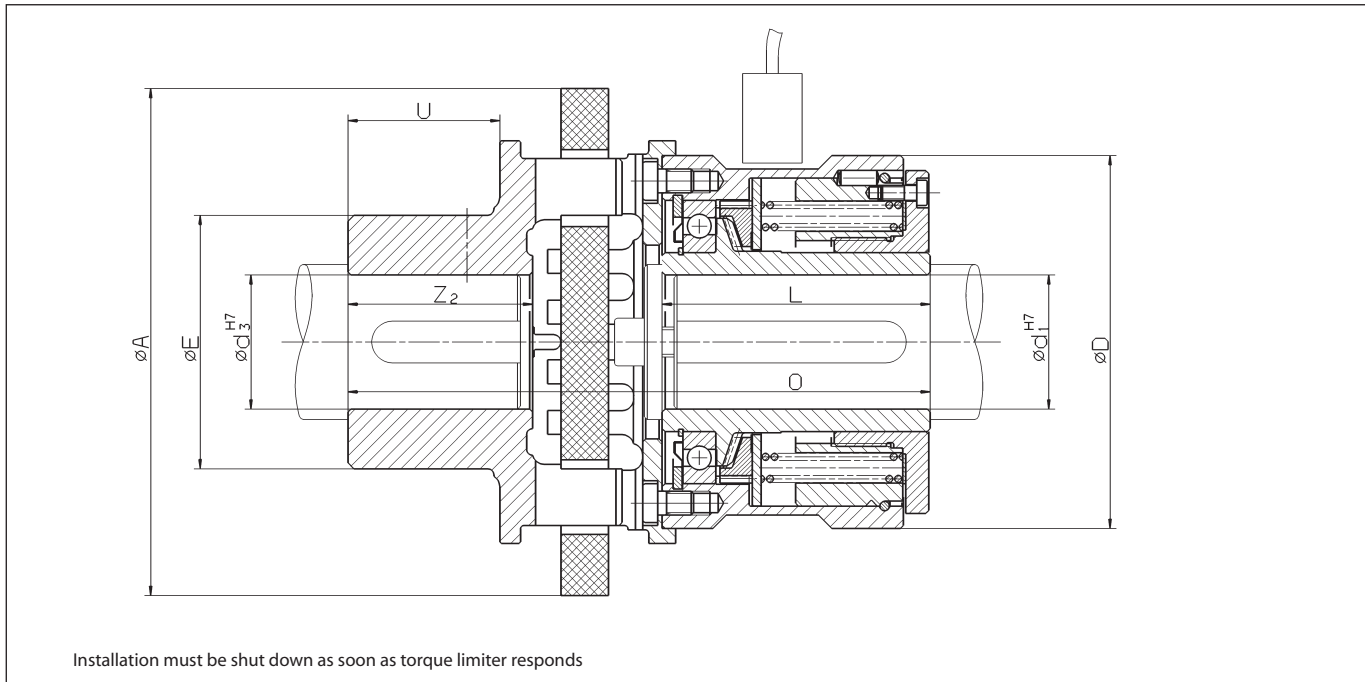

## Technical Data

type	art. no.	torque type 1			torque type 2		
		limit torque Nm	max. speed $\text{min}^{-1}$	end no.	limit torque Nm	max. speed $\text{min}^{-1}$	end no.
SCL 35.x	4472.404.xxx	15 - 85	1500	000	6 - 38	1500	100
SCL 45.x	4472.405.xxx	20 - 125	1500	000	9 - 55	1500	100
SCL 60.x	4472.406.xxx	45 - 335	1500	000	14 - 100	1500	100

## Dimensions

Type	Référence	bore $d_1$			bore $d_3$		A	D	E	L	O	U	$Z_2$	Course active
		min. mm	max. <sup>1)</sup> mm	max. <sup>2)</sup> mm	min. mm	max. <sup>1)</sup> mm								
SCL 35.x	4472.404.xxx	7	22	25	16	35	110	82	53	56	133	33	42	1,6
SCL 45.x	4472.405.xxx	9	30	32	20	42	135	100	66	71	162	41	53	2,0
SCL 60.x	4472.406.xxx	14	42	45	30	50	160	125	85	90	196	51	62	2,5

<sup>1)</sup> Max. bore diameter for keyways as per DIN 6885, p. 1

<sup>2)</sup> Max. bore diameter for keyways as per DIN 6885, p. 3

Tolerance of keyway width P9

## Example for Ordering

please indicate when ordering:	type	art. no.	preset limit torque	bore $d_1$	bore $d_3$	with proximity switch
	SCL 35. 2	4472.404. 100	7 Nm	12 mm	20 mm	see page 11

torque type  end no.

# Proximity switch for Ratcheting SIKUMAT with screw faces

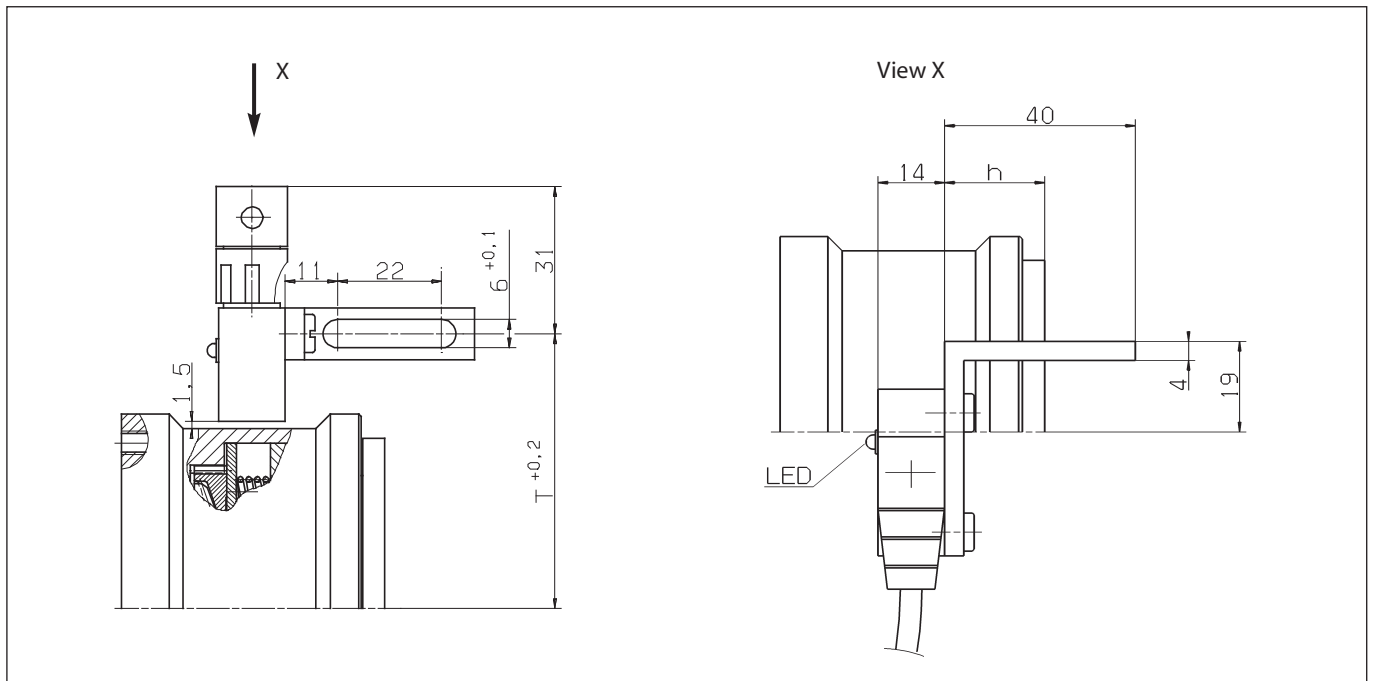

type	art. no.
Proximity switch with plug connection	3504.000.097.B024VG
Attaching plug, 90°, incl. 2 m PVC cable	2504.000.001.A00002

size	T mm	h mm
35	57,5	21
45	65,0	32
60	77,5	47

## Effect

The proximity switch's response to an overload is to react on the switching disc located internally. During normal operation the proximity switch is closed, the yellow LED is illuminated. The switching disc moves as the pre-set limit torque is reached. The proximity switch opens and the yellow LED goes out. A speed-dependent switching sequence is triggered at the output end of the limit sensor.

## Technical Data

Operating voltage:	24 V DC $\pm 20\%$
Output:	PNP-Transistor
Max. switching current:	200 mA
Internal power consumption:	10 mA
Protection type:	IP 67
Ambient temperature:	-25° ... +75° C
Dimensions (HxLxW):	23x35x14 mm

## Notes

The proximity switch is supplied with an aluminium support bracket which is fastened with 2 screws M6 according to the drawing. The fastening must be non-oscillating. Once installed, the torque limiter's maximum permissible axial movement towards the proximity switch is 0,2 mm.

# Ratcheting SIKUMAT with balls

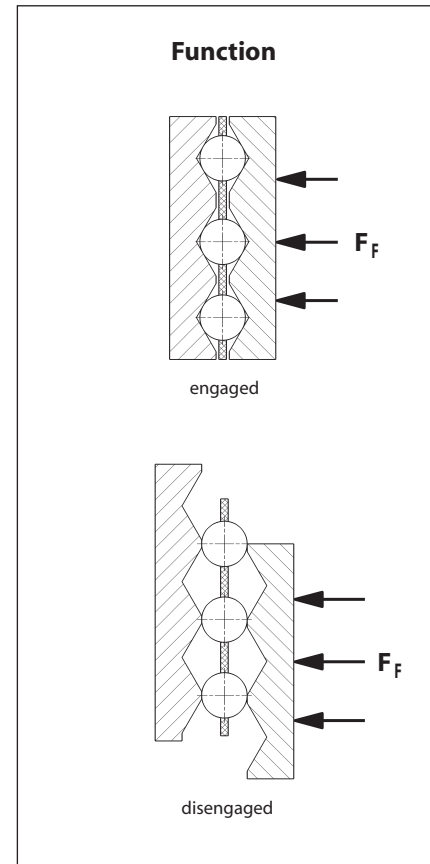
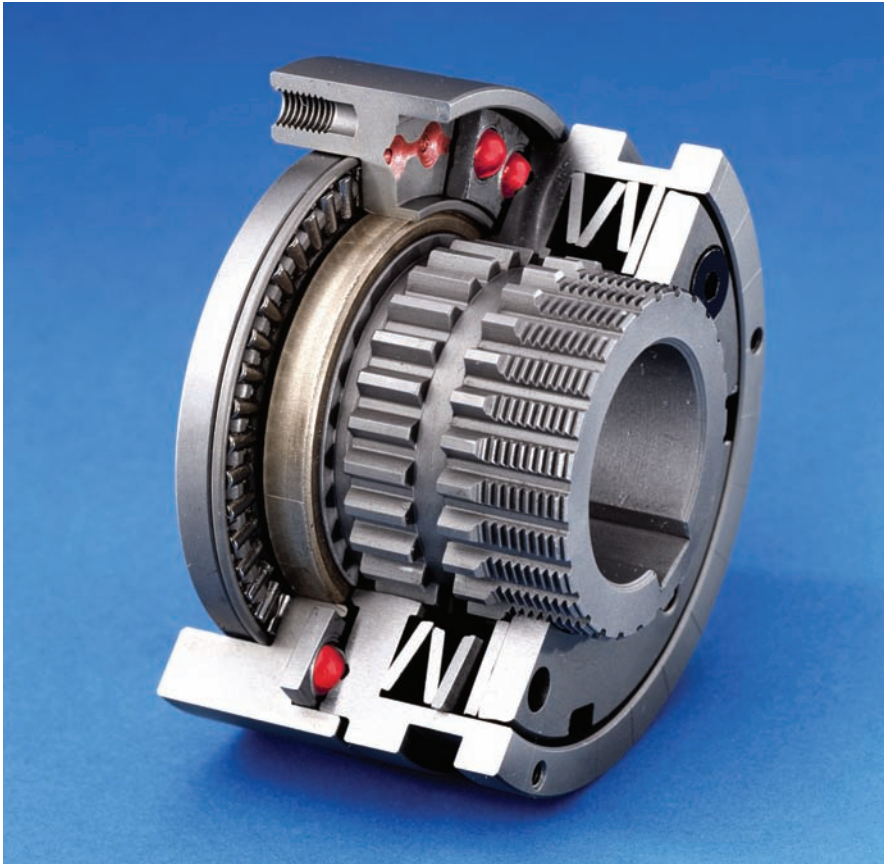

## The Ball Principle

The torque is transmitted via balls which are pressed into detents via Belleville springs. When the preset limit torque has been reached the balls rise out of their seatings and slot into the nearest respective detent – until the overload has been eliminated. This characteristic, together with the special geometry of the detent gives the SIKUMAT a very high response accuracy.

## Advantages

- Very high response accuracy through the ball principle
- Integrated fixed bearing
- Keyway in connecting flange for maximum load capacity
- Calibrated micro adjustment of torque setting possible, even post-installation
- Exchange of current torque limiters possible
- Cost effective

## Function

- When the preset limit torque has been reached the SIKUMAT ratchets.
- Automatic re-engagement of the SIKUMAT after the overload has been eliminated.
- The overload can be indicated by a proximity switch. This means that the drive can be switched off immediately or another control function can be activated.

# Ratcheting SIKUMAT with balls

## Types

### Series SG - flange design

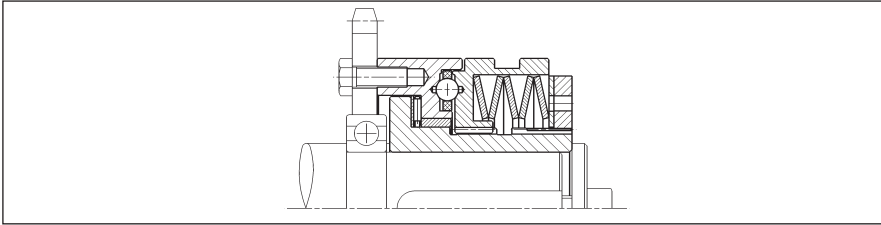

For attaching chain wheels, belt pulleys, gear wheels etc. Bearing of attached component on the shaft to be provided by the customer.

Page 14

### Series SGR - with short hub and integral needle bearing

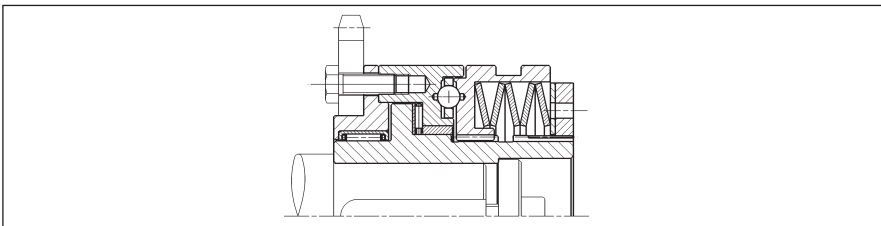

With short hub and needle bearing for narrow components to be connected

Page 15

### Series SGG - with long hub

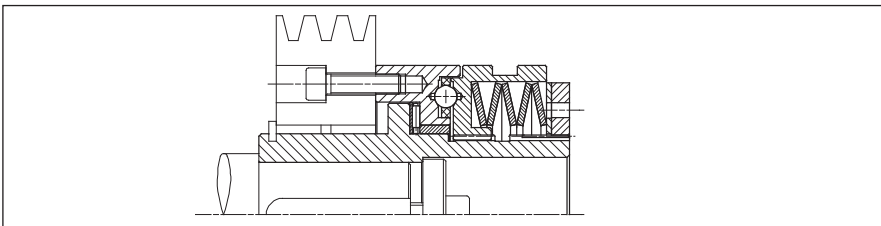

With long hub for wide components to be connected. Bearing of the attached component in the form of plain or needle bearing to be provided by the customer.

Page 16

### Series SGE - with flexible shaft coupling

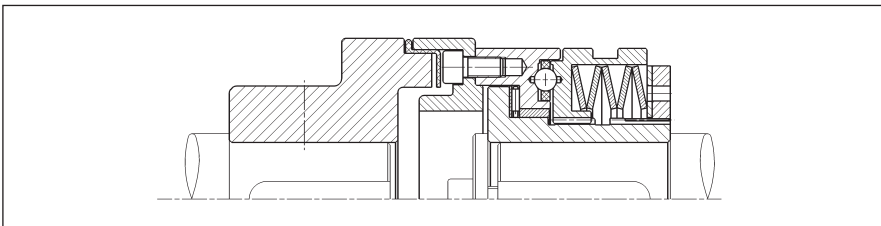

For flexible connection of two shafts. The flexible components are oil proof.

Page 17

## Notes

### Torque setting

If requested, the limit torque can be set at the factory. Setting or modification of the limit torque can also be carried out by the customer. See operating instructions for further details.

### Proximity switch

An overload can be indicated by a non-contact or a mechanical proximity switch. Further details on pages 60 and 61.

### Speed Control ESC

The RINGSPANN speed control ESC (Electronic Speed Control) monitors speed deviations and speed differences safely and also under difficult operating conditions. See catalogue 50.1 for details.

# Ratcheting SIKUMAT with balls

## Series SG - flange design

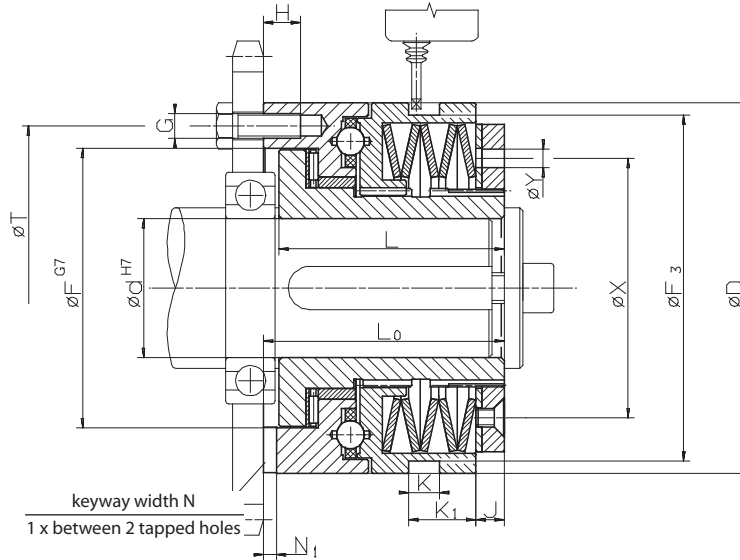

Z = number of tapped holes G on pitch circle T · Installation must be shut down as soon as torque limiter responds

### Technical Data

type	art. no.	torque type 1			torque type 2			torque type 3			torque type 4		
		limit torque Nm	max. speed min <sup>-1</sup>	end no.	limit torque Nm	max. speed min <sup>-1</sup>	end no.	limit torque Nm	max. speed min <sup>-1</sup>	end no.	limit torque Nm	max. speed min <sup>-1</sup>	end no.
SG 32.x	4478.020.xxx	2,5 - 5	3300	001	5 - 10	3300	002	10 - 20	1800	003	20 - 40	1800	004
SG 40.x	4478.025.xxx	6 - 12	2900	001	12 - 25	2900	002	25 - 55	1450	003	55 - 100	1450	004
SG 55.x	4478.035.xxx	12 - 25	2400	001	25 - 50	2400	002	50 - 120	1200	003	120 - 200	1200	004
SG 65.x	4478.045.xxx	25 - 50	2000	001	50 - 100	2000	002	100 - 250	1000	003	200 - 450	1000	004
SG 80.x	4478.055.xxx	50 - 100	1600	001	100 - 200	1600	002	200 - 500	850	003	500 - 1000	850	004
SG 90.x	4478.065.xxx	85 - 250	1400	001	230 - 600	1400	002	300 - 1000	700	003	600 - 2000	700	004

### Dimensions

Type	Référence	bore d		D	F	F <sub>3</sub>	G	H	J	K	K <sub>1</sub>	L	L <sub>0</sub>	N	N <sub>1</sub>	T	X	Y	Z	Course active
		min. mm	max. mm																	
SG 32.x	4478.020.xxx	7	20	55	41	50	M5	6,5	3	9	13,5	35	38,5	6	3,1	48	38,5	5	6	1,4
SG 40.x	4478.025.xxx	10	25	82	60	72,5	M5	8	6	9	14,5	48	52	6	3,1	70	54	6	6	2,3
SG 55.x	4478.035.xxx	14	35	100	78	90,5	M6	10	6	9	15	56	61	8	3,6	89	70	6	6	2,4
SG 65.x	4478.045.xxx	18	45	120	90,5	112	M8	12	8,5	10	22,5	72	78	10	4,1	105	84	6	6	2,7
SG 80.x	4478.055.xxx	24	55	146	105	140	M10	15	11	9	25	93,5	100	12	4,1	125	108	7	6	3,7
SG 90.x	4478.065.xxx	30	70 <sup>1)</sup>	176	120,5	170	M12	17	12	9	30	107	113,5	14	4,6	155	129	10	6	4,6

Keyway as per DIN 6885, page 1 · Tolerance of keyway width JS9

<sup>1)</sup> Keyway as per DIN 6885, page 3 · Tolerance of keyway width JS9

### Example for Ordering

please indicate when ordering:	type	art. no.	preset limit torque	bore d	with proximity switch
	SG 32. 2	4478.020. 002	7 Nm	12 mm	see p.60 and 61

torque type  end no.

# Ratcheting SIKUMAT

## with balls

### Series SGR - with short hub and integral needle bearing

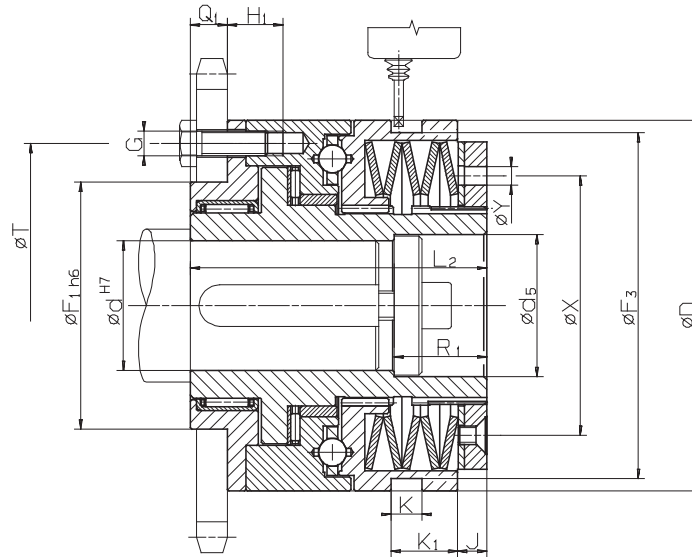

Z = number of tapped holes G on pitch circle T · Installation must be shut down as soon as torque limiter responds

#### Technical Data

type	art. no.	torque type 1			torque type 2			torque type 3			torque type 4		
		limit torque Nm	max. speed min <sup>-1</sup>	end no.	limit torque Nm	max. speed min <sup>-1</sup>	end no.	limit torque Nm	max. speed min <sup>-1</sup>	end no.	limit torque Nm	max. speed min <sup>-1</sup>	end no.
SGR 32.x	4478.920.xxx	2,5 - 5	3 300	001	5 - 10	3 300	002	10 - 20	1 800	003	20 - 40	1 800	004
SGR 40.x	4478.925.xxx	6 - 12	2 900	001	12 - 25	2 900	002	25 - 55	1 450	003	55 - 100	1 450	004
SGR 55.x	4478.935.xxx	12 - 25	2 400	001	25 - 50	2 400	002	50 - 120	1 200	003	120 - 200	1 200	004
SGR 65.x	4478.945.xxx	25 - 50	2 000	001	50 - 100	2 000	002	100 - 250	1 000	003	200 - 450	1 000	004
SGR 80.x	4478.955.xxx	50 - 100	1 600	001	100 - 200	1 600	002	200 - 500	850	003	500 - 1 000	850	004
SGR 90.x	4478.965.xxx	85 - 250	1 400	001	230 - 600	1 400	002	300 - 1 000	700	003	600 - 2 000	700	004

#### Dimensions

Type	Référence	bore d		d <sub>5</sub>	D	F <sub>1</sub>	F <sub>3</sub>	G	H <sub>1</sub>	J	K	K <sub>1</sub>	L <sub>2</sub>	Q <sub>1</sub>	R <sub>1</sub>	T	X	Y	Z	Course active
		min. mm	max. mm																	
SGR 32.x	4478.920.xxx	7	20	21	55	38	50	M5	11,5	3	9	13,5	51,5	8	15	48	38,5	5	6	1,4
SGR 40.x	4478.925.xxx	10	25	26	82	50	72,5	M5	16	6	9	14,5	70	10	20	70	54	6	6	2,3
SGR 55.x	4478.935.xxx	14	35	36	100	60	90,5	M6	15	6	9	15	78	12	25	89	70	6	6	2,4
SGR 65.x	4478.945.xxx	18	45	46	120	80	112	M8	18	8,5	10	22,5	96	12	30	105	84	6	6	2,7
SGR 80.x	4478.955.xxx	24	55	56	146	100	140	M10	23,5	11	9	25	124,5	16	30	125	108	7	6	3,7
SGR 90.x	4478.965.xxx	30	70 <sup>1)</sup>	66	176	120	170	M12	25,5	12	9	30	140	18	30	155	129	10	6	4,6

Keyway as per DIN 6885, page 1 · Tolerance of keyway width JS9

<sup>1)</sup> Keyway as per DIN 6885, page 3 · Tolerance of keyway width JS9

#### Example for Ordering

please indicate when ordering:	type	art. no.	preset limit torque	bore d	with proximity switch
	SGR 32. 2	4478.920. 002	7 Nm	12 mm	see p. 60 and 61

torque type  end no.

# Ratcheting SIKUMAT with balls

## Series SGG - with long hub

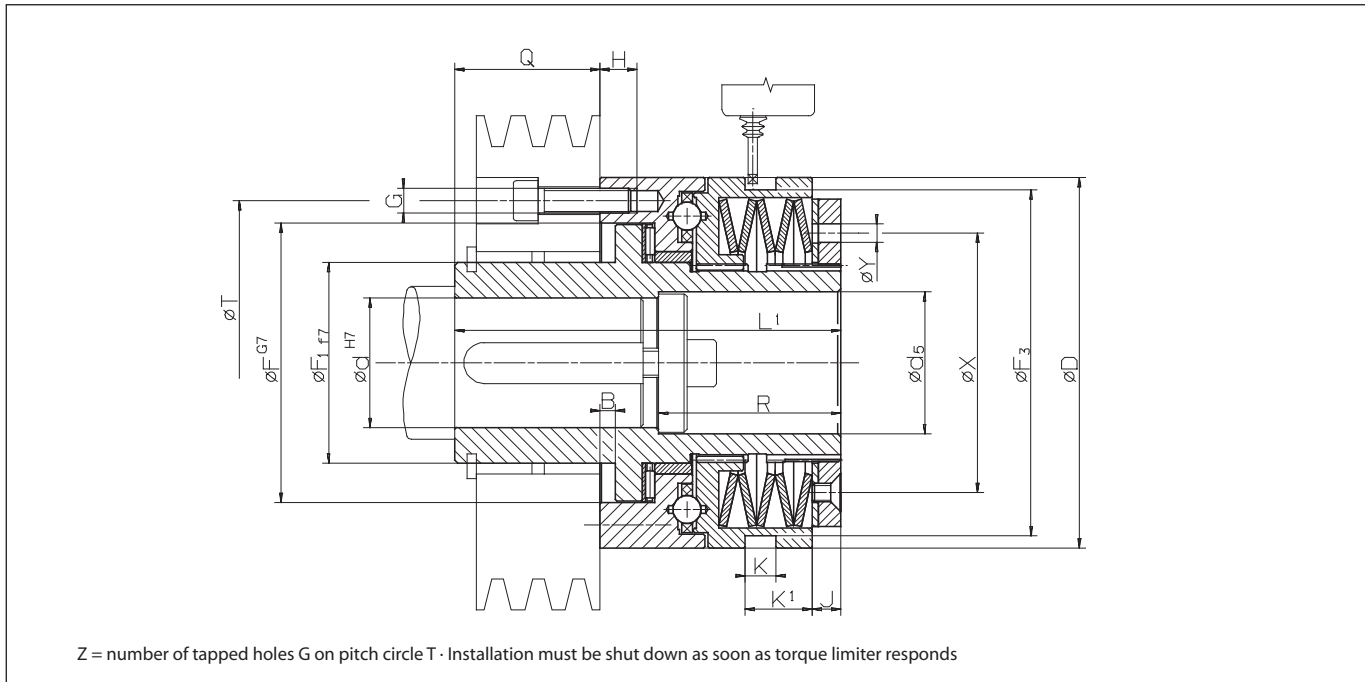

### Technical Data

type	art. no.	torque type 1			torque type 2			torque type 3			torque type 4		
		limit torque Nm	max. speed min <sup>-1</sup>	end no.	limit torque Nm	max. speed min <sup>-1</sup>	end no.	limit torque Nm	max. speed min <sup>-1</sup>	end no.	limit torque Nm	max. speed min <sup>-1</sup>	end no.
SGG 32.x	4478.120.xxx	2,5 - 5	3300	001	5 - 10	3300	002	10 - 20	1800	003	20 - 40	1800	004
SGG 40.x	4478.125.xxx	6 - 12	2900	001	12 - 25	2900	002	25 - 55	1450	003	55 - 100	1450	004
SGG 55.x	4478.135.xxx	12 - 25	2400	001	25 - 50	2400	002	50 - 120	1200	003	120 - 200	1200	004
SGG 65.x	4478.145.xxx	25 - 50	2000	001	50 - 100	2000	002	100 - 250	1000	003	200 - 450	1000	004
SGG 80.x	4478.155.xxx	50 - 100	1600	001	100 - 200	1600	002	200 - 500	850	003	500 - 1000	850	004
SGG 90.x	4478.165.xxx	85 - 250	1400	001	230 - 600	1400	002	300 - 1000	700	003	600 - 2000	700	004

### Dimensions

Type	Référence	bore d		d <sub>5</sub>	B	D	F	F <sub>1</sub>	F <sub>3</sub>	G	H	J	K	K <sub>1</sub>	L <sub>1</sub>	Q	R	T	X	Y	Z	Course active
		min. mm	max. mm																			
SGG 32.x	4478.120.xxx	7	20	21	4	55	41	28	50	M5	6,5	3	9	13,5	66	27,5	25,5	48	38,5	5	6	1,4
SGG 40.x	4478.125.xxx	10	25	26	4	82	60	38	72,5	M5	8	6	9	14,5	83	33	35	70	54	6	6	2,3
SGG 55.x	4478.135.xxx	14	35	36	5	100	78	52	90,5	M6	10	6	9	15	100	39	45	89	70	6	6	2,4
SGG 65.x	4478.145.xxx	18	45	46	5	120	90,5	65	112	M8	12	8,5	10	22,5	125	47	59	105	84	6	6	2,7
SGG 80.x	4478.155.xxx	24	55	56	6,5	146	105	78	140	M10	15	11	9	25	152,5	52,5	60	125	108	7	6	3,7
SGG 90.x	4478.165.xxx	30	70 <sup>1)</sup>	66	6,5	176	120,5	90	170	M12	17	12	9	30	171	57,5	60	155	129	10	6	4,6

Keyway as per DIN 6885, page 1 · Tolerance of keyway width JS9

<sup>1)</sup> Keyway as per DIN 6885, page 1 · Tolerance of keyway width JS9

### Example for Ordering

please indicate when ordering:	type	art. no.	preset limit torque	bore d	with proximity switch
	SGG 32. 2	4478.120. 002	7 Nm	12 mm	see p.60 and 61

torque type  end no.



# Ratcheting SIKUMAT

## with balls

### Series SGE - with flexible shaft coupling

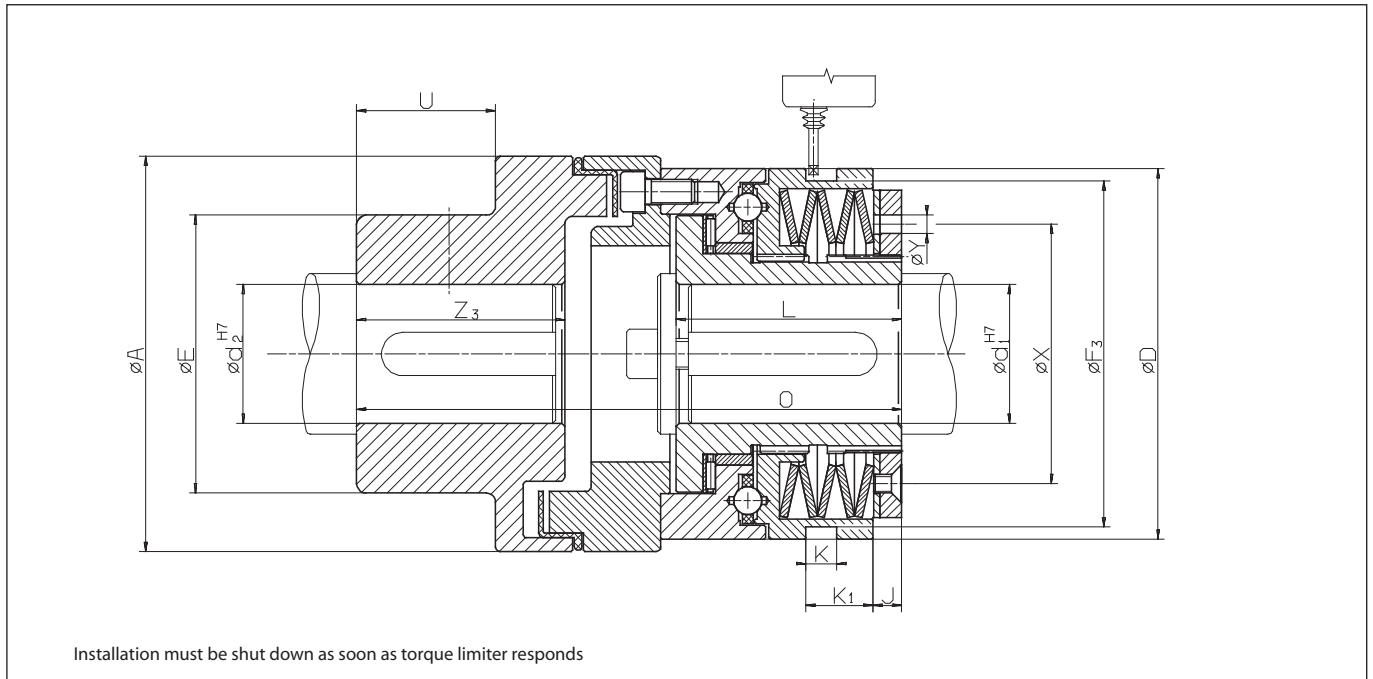

### Technical Data

type	art. no.	torque type 1			torque type 2			torque type 3			torque type 4		
		limit torque Nm	max. speed min <sup>-1</sup>	end no.	limit torque Nm	max. speed min <sup>-1</sup>	end no.	limit torque Nm	max. speed min <sup>-1</sup>	end no.	limit torque Nm	max. speed min <sup>-1</sup>	end no.
SGE 32.x	4478.620.xxx	2,5 - 5	3 300	001	5 - 10	3 300	002	10 - 20	1 800	003	20 - 40	1 800	004
SGE 40.x	4478.625.xxx	6 - 12	2 900	001	12 - 25	2 900	002	25 - 55	1 450	003	55 - 100	1 450	004
SGE 55.x	4478.635.xxx	12 - 25	2 400	001	25 - 50	2 400	002	50 - 120	1 200	003	120 - 200	1 200	004
SGE 65.x	4478.645.xxx	25 - 50	2 000	001	50 - 100	2 000	002	100 - 250	1 000	003	200 - 450	1 000	004
SGE 80.x	4478.655.xxx	50 - 100	1 600	001	100 - 200	1 600	002	200 - 500	850	003	500 - 1 000	850	004
SGE 90.x	4478.665.xxx	85 - 250	1 400	001	230 - 600	1 400	002	300 - 1 000	700	003	600 - 2 000	700	004

### Dimensions

Type	Référence	bore d <sub>1</sub>		d <sub>2</sub> max. mm	A mm	E mm	D mm	F <sub>3</sub> mm	J mm	K mm	K <sub>1</sub> mm	L mm	O mm	U mm	X mm	Y mm	Z <sub>3</sub> mm	Course active mm
		min. mm	max. mm															
SGE 32.x	4478.620.xxx	7	20	30	67	46	55	50	3	9	13,5	35	86	15	38,5	5	28	1,4
SGE 40.x	4478.625.xxx	10	25	50	112	79	82	72,5	6	9	14,5	48	137,5	38	54	6	58	2,3
SGE 55.x	4478.635.xxx	14	35	50	112	79	100	90,5	6	9	15	56	147	38	70	6	58	2,4
SGE 65.x	4478.645.xxx	18	45	60	128	90	120	112	8,5	10	22,5	72	176,5	45	84	6	67	2,7
SGE 80.x	4478.655.xxx	24	55	60	148	90	146	140	11	9	25	93,5	211,5	45	108	7	67	3,7
SGE 90.x	4478.665.xxx	30	70 <sup>1)</sup>	70	177	107	176	170	12	9	30	107	242,5	52	129	10	75	4,6
SGE 90.4	4478.665.xxx	30	70 <sup>1)</sup>	90	198	140	176	170	12	9	30	107	272	52	129	10	75	4,6

Keyway as per DIN 6885, page 1 · Tolerance of keyway width JS9

<sup>1)</sup> Keyway as per DIN 6885, page 1 · Tolerance of keyway width JS9

### Example for Ordering

please indicate when ordering:	type	art. no.	preset limit torque	bore d <sub>1</sub>	bore d <sub>2</sub>	with proximity switch
	SGE 32. 2	4478.620. 002	7 Nm	12 mm	25 mm	see pages 60 and 61

torque type  end no.

# Ratcheting SIKUMAT - Backlash free with balls

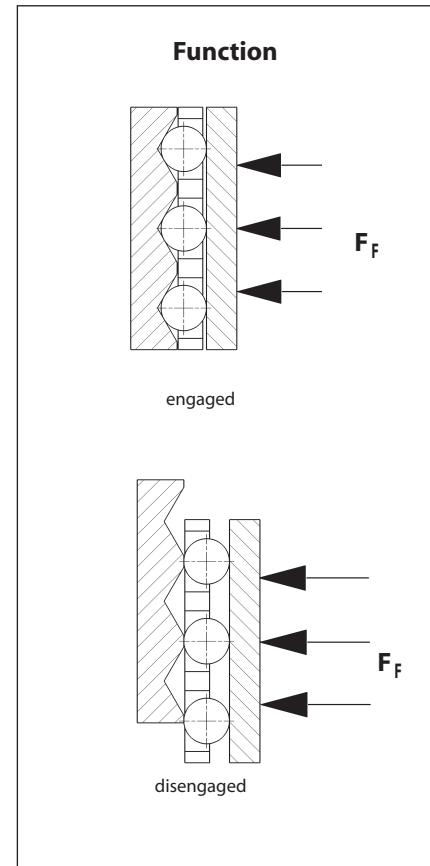

## The Ball Principle - Backlash free

The torque is transmitted via balls which are pressed into V-shaped grooves. The grooves are arranged axially on the output side and radially on the input side, which means that torque can be transmitted backlash free in both directions of rotation. As the preset limit torque is reached, the balls rise out of the axial grooves and ratchet into the respective next axial groove – until the overload has been eliminated. The negative characteristic disc springs give extremely fast, accurate and consistent overload protection.

## Advantages

- Backlash free in both directions of rotation
- Compact design
- Integral ball bearing for supporting the component to be connected
- Very high response accuracy through the ball principle
- Simple and backlash free fastening onto shaft with integral cone clamping element
- Calibrated micro adjustment of torque setting possible, even post-installation
- Exchange of current torque limiters possible

## Function

- When the preset limit torque has been reached the SIKUMAT ratchets.
- Automatic re-engagement of the SIKUMAT after the overload has been eliminated.
- The overload can be indicated by a proximity switch. This means that the drive can be switched off immediately or another control function can be activated.

# Ratcheting SIKUMAT - Backlash free with balls

## Types

### Series ST - flange design

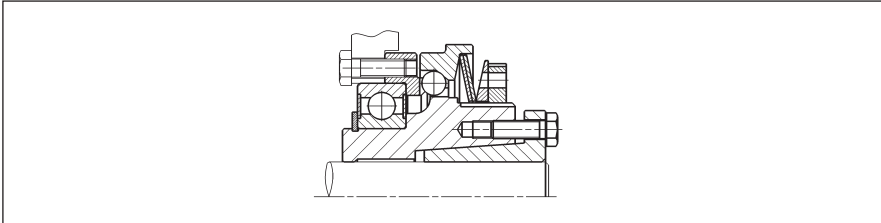

For attaching chain wheels, belt pulleys, gear wheels etc. Support of the component to be connected directly on the integral ball bearing.

Page 20

### Series STG - with long hub

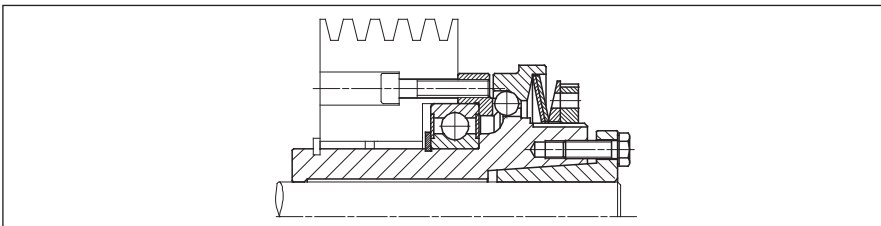

With long hub for wide components to be connected. Support of the component to be connected directly on the integral ball bearing; additional radial bearing to be provided by the customer.

Page 21

### Series STE - with flexible shaft coupling

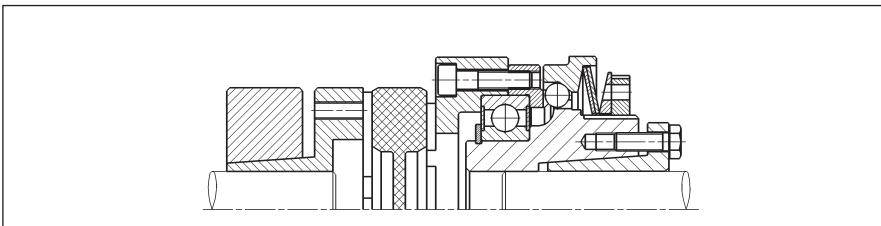

For flexible connection of two shafts.

Page 22

### Series STL - with torsionally rigid shaft coupling

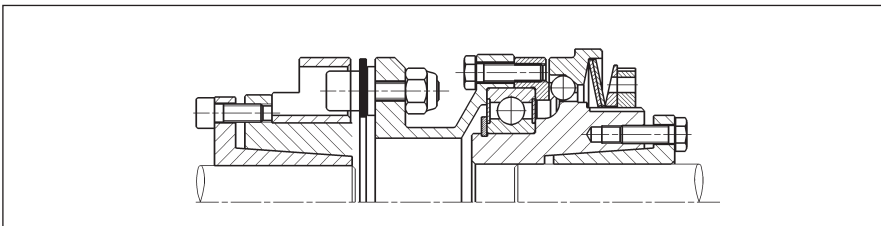

For rigid connection of two shafts.

Page 23

## Notes

### Torque setting

If requested, the limit torque can be set at the factory. Setting or modification of the limit torque can also be carried out by the customer. See operating instructions for further details.

### Proximity switch

An overload can be indicated by a non-contact or a mechanical proximity switch. Further details on pages 60 and 61.

### Keyway design

Types ST and STG with bore and keyway are available on request.

### Speed Control ESC

The RINGSPANN speed control ESC (Electronic Speed Control) monitors speed deviations and speed differences safely and also under difficult operating conditions. See catalogue 50.1 for details.

# Ratcheting SIKUMAT - Backlash free with balls

## Series ST - flange design

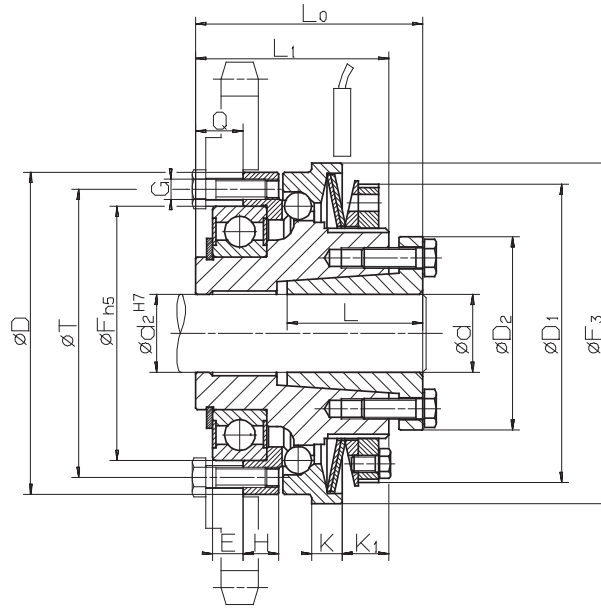

Z = number of tapped holes G on pitch circle T · Installation must be shut down as soon as torque limiter responds

### Technical Data

type	art. no.	torque type 1			torque type 2			torque type 3		
		limit torque Nm	max. speed min <sup>-1</sup>	end no.	limit torque Nm	max. speed min <sup>-1</sup>	end no.	limit torque Nm	max. speed min <sup>-1</sup>	end no.
ST 30.x	4479.025.xxx	5 - 14	4000	001	10 - 28	4000	002	20 - 60	4000	003
ST 40.x	4479.030.xxx	9 - 27	3000	001	18 - 54	3000	002	38 - 115	3000	003
ST 45.x	4479.040.xxx	19 - 60	2500	001	38 - 125	2500	002	70 - 255	2500	003
ST 55.x	4479.050.xxx	35 - 110	2000	001	80 - 220	2000	002	160 - 440	2000	003
ST 65.x	4479.060.xxx	80 - 185	1200	001	160 - 370	1200	002	320 - 740	1200	003

### Dimensions

Type	Référence	bore d*		D	D <sub>1</sub>	D <sub>2</sub>	E	F	F <sub>3</sub>	G	H	K	K <sub>1</sub>	L	L <sub>0</sub>	L <sub>1</sub>	Q	T	Z	Course active
		min. mm	max. mm																	
ST 30.x	4479.025.xxx	10	20	65	63	40,5	5	47	70	M4	7,5	7	12	26	47	40	8	56	8	1,2
ST 30.x	4479.025.xxx	19	25	65	63	42	5	47	70	M4	7,5	7	12	26	47	40	8	56	8	1,2
ST 40.x	4479.030.xxx	15	30	80	77	57	7	62	85	M5	8	8	12	31	56	46	11	71	8	1,5
ST 45.x	4479.040.xxx	19	30	95	88	57	9	75	100	M6	10,5	9	14	40	67	57	14	85	8	1,8
ST 45.x	4479.040.xxx	32	40	95	88	64	9	75	100	M6	10,5	9	14	31	67	57	14	85	8	1,8
ST 55.x	4479.050.xxx	32	50	110	100	73,5	10	90	115	M6	12	10	16	29	73	63	16	100	8	2,0
ST 65.x	4479.060.xxx	32	50	130	122	73,5	10	100	135	M8	12	12	21	29	85	75	18	116	8	2,2
ST 65.x	4479.060.xxx	55	60	130	122	89	10	100	135	M8	12	12	21	45,5	86	75	18	116	8	2,2

Hub bore diameter d<sub>2</sub> is equal to the selected diameter d and serves as an additional centering guide.

\*Available bore diameters d: 10, 11, 12, 14, 15, 16, 18, 19, 20, 22, 24, 25, 28, 30, 32, 35, 38, 40, 42, 45, 48, 50, 55 and 60 mm.

### Example for Ordering

please indicate when ordering:	type	art. no.	preset limit torque	bore d	with proximity switch
	ST 40. 2	4479.030. 002	25 Nm	20 mm	see p.60 and 61

torque type  end no.

# Ratcheting SIKUMAT - Backlash free with balls

## Series STG - with long hub

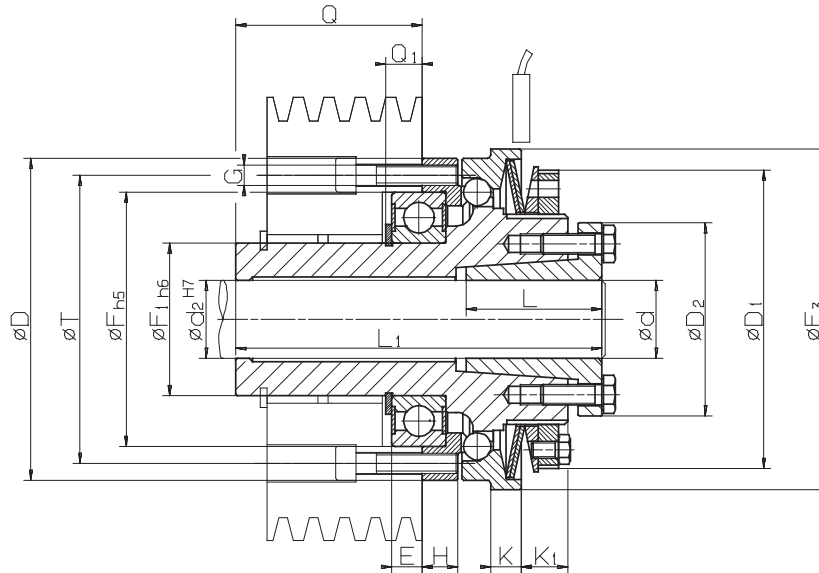

Z = number of tapped holes G on pitch circle T · Installation must be shut down as soon as torque limiter responds

### Technical Data

type	art. no.	torque type 1			torque type 2			torque type 3		
		limit torque Nm	max. speed min <sup>-1</sup>	end no.	limit torque Nm	max. speed min <sup>-1</sup>	end no.	limit torque Nm	max. speed min <sup>-1</sup>	end no.
STG 30.x	4479.125.xxx	5 - 14	4000	001	10 - 28	4000	002	20 - 60	4000	003
STG 40.x	4479.130.xxx	9 - 27	3000	001	18 - 54	3000	002	38 - 115	3000	003
STG 45.x	4479.140.xxx	19 - 60	2500	001	38 - 125	2500	002	70 - 255	2500	003
STG 55.x	4479.150.xxx	35 - 110	2000	001	80 - 220	2000	002	160 - 440	2000	003
STG 65.x	4479.160.xxx	80 - 185	1200	001	160 - 370	1200	002	320 - 740	1200	003

### Dimensions

Type	Référence	bore d*		D	D <sub>1</sub>	D <sub>2</sub>	E	F	F <sub>1</sub>	F <sub>3</sub>	G	H	K	K <sub>1</sub>	L	L <sub>1</sub>	Q	Q <sub>1</sub>	T	Z	Course active
		min. mm	max. mm																		
STG 30.x	4479.125.xxx	10	20	65	63	40,5	5	47	30	70	M4	7,5	7	12	26	72	33	6,5	56	8	1,2
STG 30.x	4479.125.xxx	19	25	65	63	42	5	47	30	70	M4	7,5	7	12	26	72	33	6,5	56	8	1,2
STG 40.x	4479.130.xxx	15	30	80	77	57	7	62	40	85	M5	8	8	12	31	88	43	8,75	71	8	1,5
STG 45.x	4479.140.xxx	19	30	95	88	57	9	75	45	100	M6	10,5	9	14	40	108	55	11,5	85	8	1,8
STG 45.x	4479.140.xxx	32	40	95	88	64	9	75	45	100	M6	10,5	9	14	31	108	55	11,5	85	8	1,8
STG 55.x	4479.150.xxx	32	50	110	100	73,5	10	90	55	115	M6	12	10	16	29	124	67	13	100	8	2,0
STG 65.x	4479.160.xxx	32	50	130	122	73,5	10	100	65	135	M8	12	12	21	29	140	73	14	116	8	2,2
STG 65.x	4479.160.xxx	55	60	130	122	89	10	100	65	135	M8	12	12	21	45,5	141	73	14	116	8	2,2

Diameter d<sub>2</sub> at the end of the long hub is equal to the selected diameter d and serves as an additional centering.

\*Available bore diameters d: 10, 11, 12, 14, 15, 16, 18, 19, 20, 22, 24, 25, 28, 30, 32, 35, 38, 40, 42, 45, 48, 50, 55 and 60 mm.

### Example for Ordering

please indicate when ordering:	type	art. no.	preset limit torque	bore d	with proximity switch
	STG 65.1	4479.160. 001	90 Nm	60 mm	see p. 60 and 61

torque type  end no.

# Ratcheting SIKUMAT - Backlash free with balls

## Series STE - with flexible shaft coupling

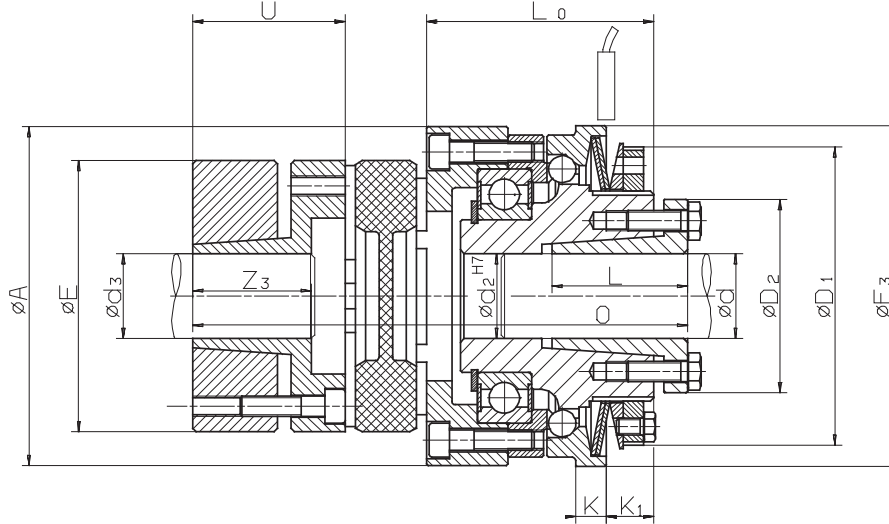

Installation must be shut down as soon as torque limiter responds

### Technical Data

type	art. no.	torque type 1			torque type 2			torque type 3		
		limit torque Nm	max. speed min <sup>-1</sup>	end no.	limit torque Nm	max. speed min <sup>-1</sup>	end no.	limit torque Nm	max. speed min <sup>-1</sup>	end no.
STE 30.x	4479.625.xxx	5 - 14	4000	001	10 - 28	4000	002	20 - 60	4000	003
STE 40.x	4479.630.xxx	9 - 27	3000	001	18 - 54	3000	002	38 - 115	3000	003
STE 45.x	4479.640.xxx	19 - 60	2500	001	38 - 125	2500	002	70 - 255	2500	003
STE 55.x	4479.650.xxx	35 - 110	2000	001	80 - 220	2000	002	160 - 440	2000	003
STE 65.x	4479.660.xxx	80 - 185	1200	001	160 - 370	1200	002	320 - 740	1200	003

### Dimensions

Type	Référence	bore d*		bore d <sub>3</sub> **		A	D <sub>1</sub>	D <sub>2</sub>	E	F <sub>3</sub>	K	K <sub>1</sub>	L	L <sub>0</sub>	O	U	Z <sub>3</sub>	Course active
		min. mm	max. mm	mm	mm													
STE 30.x	4479.625.xxx	10	20	15	28	70	63	40,5	55	70	7	12	26	47	102	30	30	1,2
STE 30.x	4479.625.xxx	19	25	15	28	70	63	42	55	70	7	12	26	47	102	30	30	1,2
STE 40.x	4479.630.xxx	15	30	15	38	85	77	57	65	85	8	12	31	54,5	119,5	35	35	1,5
STE 45.x	4479.640.xxx	19	30	20	45	100	88	57	80	100	9	14	40	67	146	45	45	1,8
STE 45.x	4479.640.xxx	32	40	20	45	100	88	64	80	100	9	14	31	67	146	45	45	1,8
STE 55.x	4479.650.xxx	32	50	25	50	115	100	73,5	95	115	10	16	29	73	159	50	50	2,0
STE 65.x	4479.660.xxx	32	50	30	55	135	122	73,5	105	135	12	21	29	87	182	56	56	2,2
STE 65.x	4479.660.xxx	55	60	30	55	135	122	89	105	135	12	21	45,5	87	182	56	56	2,2

Hub bore diameter d<sub>2</sub> is equal to the selected diameter d and serves as an additional centering guide.

\*Available bore diameters d: 10, 11, 12, 14, 15, 16, 18, 19, 20, 22, 24, 25, 28, 30, 32, 35, 38, 40, 42, 45, 48, 50, 55 and 60 mm.

\*\*Available bore diameters d<sub>3</sub>: 15, 16, 19, 20, 24, 25, 28, 30, 32, 35, 38, 40, 42, 45, 48, 50 and 55 mm.

### Example for Ordering

please indicate when ordering:	type	art. no.	preset limit torque	bore d	bore d <sub>3</sub>	with proximity switch
	STE 30.1	4479.625. 001	10 Nm	12 mm	20 mm	see pages 60 and 61

torque type  end no.

# Ratcheting SIKUMAT - Backlash free with balls

## Series STL - with torsionally rigid shaft coupling

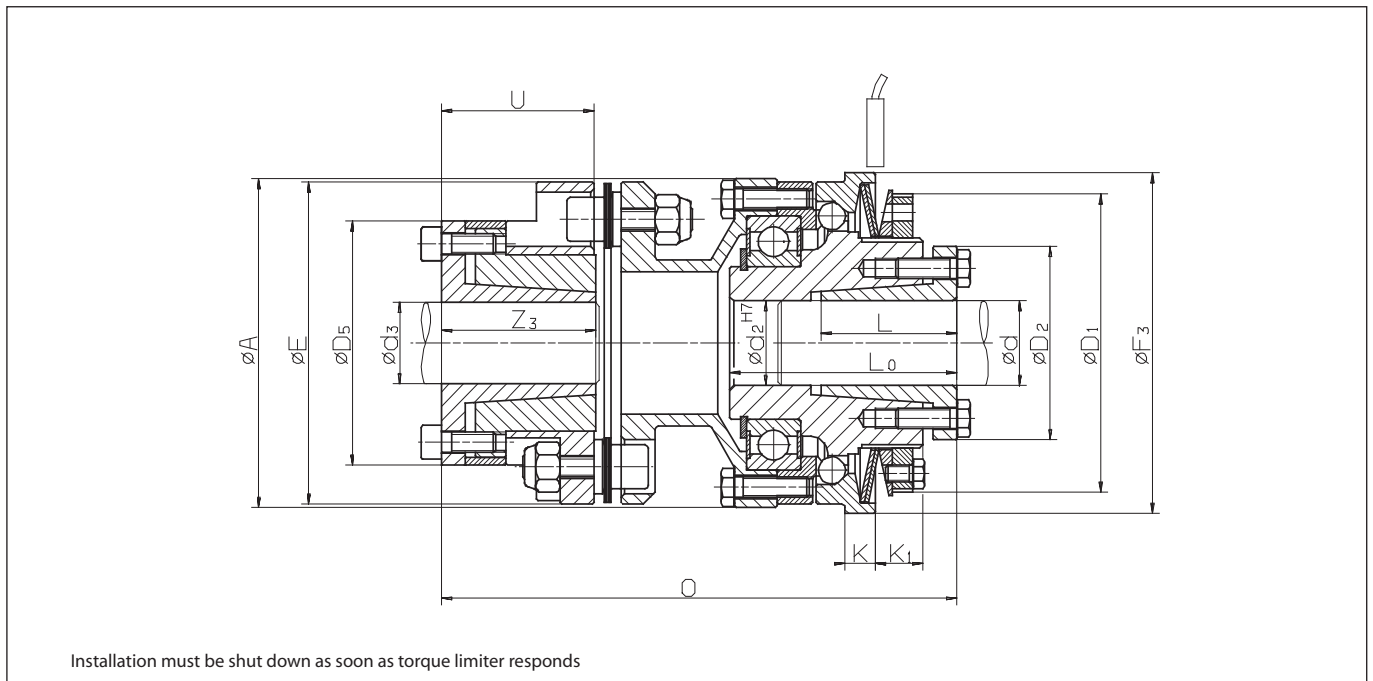

### Technical Data

type	art. no.	torque type 1			torque type 2			torque type 3		
		limit torque Nm	max. speed min <sup>-1</sup>	end no.	limit torque Nm	max. speed min <sup>-1</sup>	end no.	limit torque Nm	max. speed min <sup>-1</sup>	end no.
STL 30.x	4479.425.xxx	5 - 14	4000	001	10 - 28	4000	002	20 - 60	4000	003
STL 40.x	4479.430.xxx	9 - 27	3000	001	18 - 54	3000	002	38 - 115	3000	003
STL 45.x	4479.440.xxx	19 - 60	2500	001	38 - 125	2500	002	70 - 255	2500	003
STL 55.x	4479.450.xxx	35 - 110	2000	001	80 - 220	2000	002	160 - 440	2000	003
STL 65.x	4479.460.xxx	80 - 185	1200	001	160 - 370	1200	002	320 - 740	1200	003

### Dimensions

Type	Référence	bore d*		bore d <sub>3</sub> **		A	D <sub>1</sub>	D <sub>2</sub>	D <sub>5</sub>	E	F <sub>3</sub>	K	K <sub>1</sub>	L	L <sub>0</sub>	O	U	Z <sub>3</sub>	Course active
		min. mm	max. mm	mm	mm														
STL 30.x	4479.425.xxx	10	20	11	20	65	63	40,5	42	53	70	7	12	26	47	95,5	25,5	26,5	1,2
STL 30.x	4479.425.xxx	19	25	11	20	65	63	42	42	53	70	7	12	26	47	95,5	25,5	26,5	1,2
STL 40.x	4479.430.xxx	15	30	15	30	80	77	57	58	72	85	8	12	31	56	114,5	33	31	1,5
STL 45.x	4479.440.xxx	19	40	19	30	97	88	57	58	72	100	9	14	40	67	128	33	31	1,8
STL 45.x	4479.440.xxx	19	40	24	42	97	88	64	72	89	100	9	14	31	67	150	44,5	45	1,8
STL 55.x	4479.450.xxx	32	50	24	42	111	100	73,5	72	89	115	10	16	29	73	153,5	44,5	45	2,0
STL 65.x	4479.460.xxx	32	50	32	42	131	122	73,5	79	118	135	12	21	29	85	163,5	35	29	2,2
STL 65.x	4479.460.xxx	55	60	45	60	131	122	89	92	118	135	12	21	45,5	86	172,5	44	44	2,2

Hub bore diameter d<sub>2</sub> is equal to the selected diameter d and serves as an additional centering guide.

\*Available bore diameters d: 10, 11, 12, 14, 15, 16, 18, 19, 20, 22, 24, 25, 28, 30, 32, 35, 38, 40, 42, 45, 48, 50, 55 and 60 mm.

\*\*Available bore diameters d<sub>3</sub>: 15, 16, 19, 20, 24, 25, 28, 30, 32, 35, 38, 40, 42, 45, 48, 50 and 55 mm.

### Example for Ordering

please indicate when ordering:	type	art. no.	preset limit torque	bore d	bore d <sub>3</sub>	with proximity switch
	STL 55.3	4479.450. 003	420 Nm	45 mm	35 mm	see pages 60 and 61

torque type  end no.

# Synchronous Ratcheting SIKUMAT with single rollers

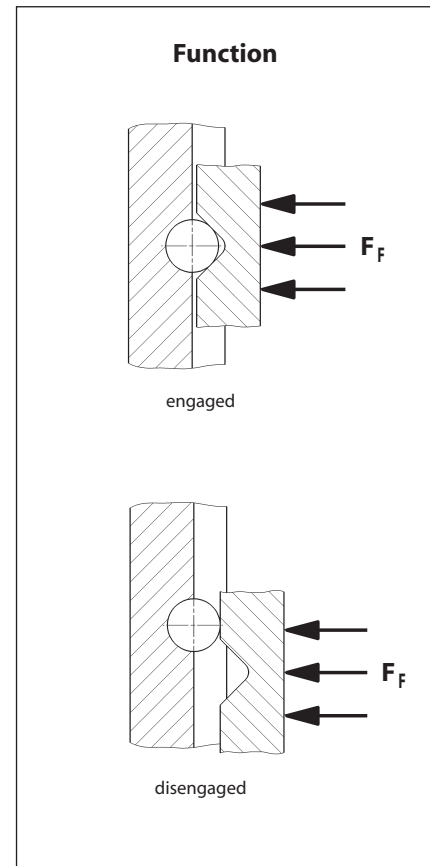
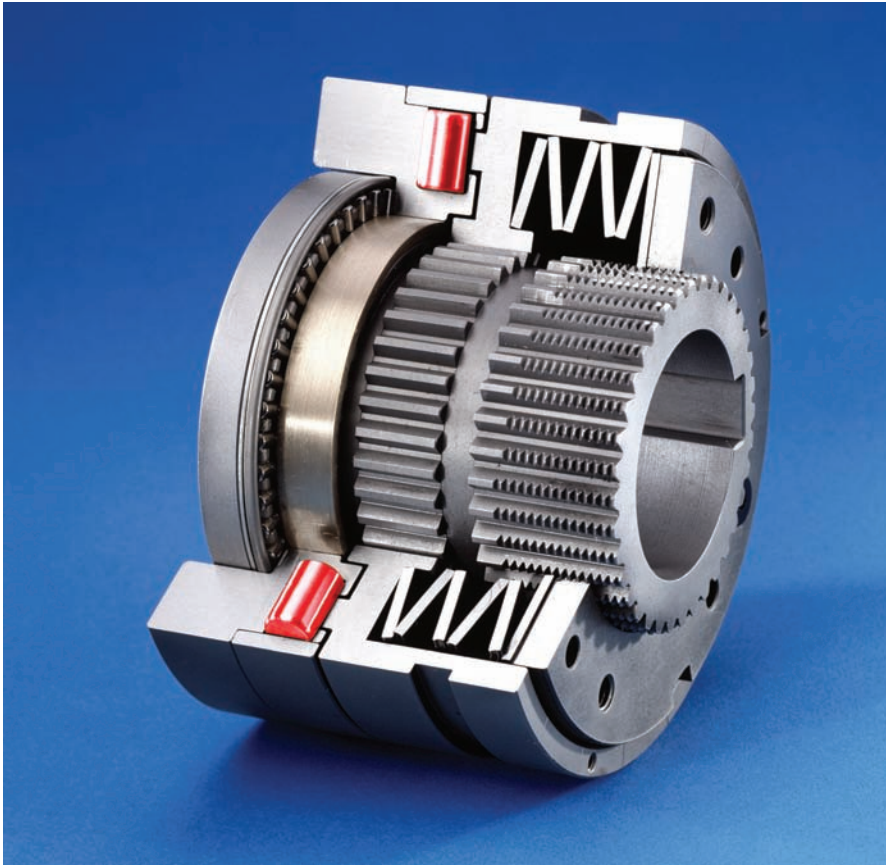

## The Single Roller Principle

The torque is transmitted via rollers which are pressed by Belleville springs into detents. When the preset limit torque has been reached, the detent ring is axially displaced. Re-engagement is effected synchronously after 360° due to the asymmetrical division of the detents.

## Advantages

- Synchronous re-engagement after 360°
- Integral fixed bearing
- Driving keyway in the connecting flange for maximum load capacity
- Calibrated micro adjustment of torque setting possible, even post-installation
- Exchange of current torque limiters possible
- Cost effective

## Function

- When the preset limit torque has been reached the SIKUMAT ratchets.
- Following elimination of overload automatic synchronous re-engagement of the SIKUMAT to the starting position after 360°.
- The overload can be indicated by a proximity switch. This means that the drive can be switched off immediately or another control function can be activated.



# Synchronous Ratcheting SIKUMAT with single rollers

## Types

### Series SN - flange design

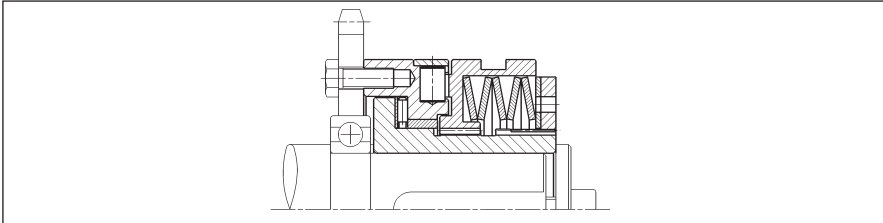

For attaching chain wheels, belt pulleys, gear wheels etc. Bearing of attached component on the shaft to be provided by the customer.

Page 26

### Series SNR - with short hub and integral needle bearing

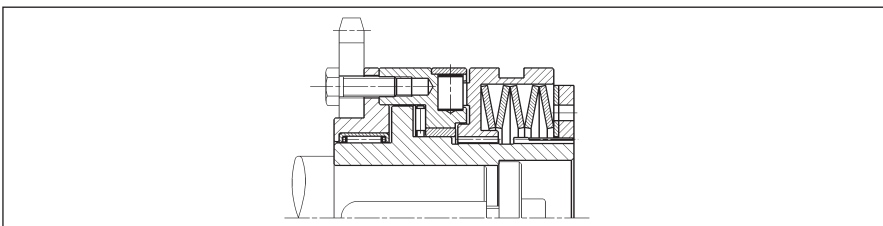

With short hub and needle bearing for narrow components to be connected.

Page 27

### Series SNG - with long hub

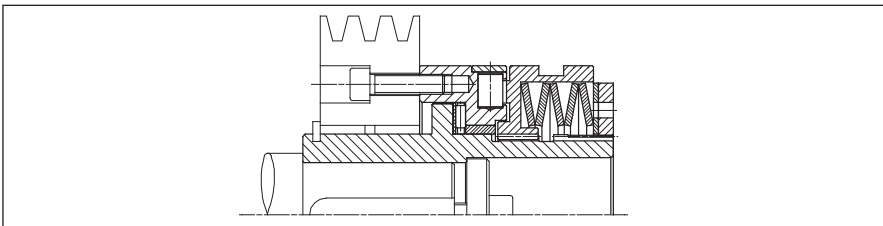

With long hub for wide components to be connected. Bearings of the attached component to be provided by the customer.

Page 28

### Series SNE - with flexible shaft coupling

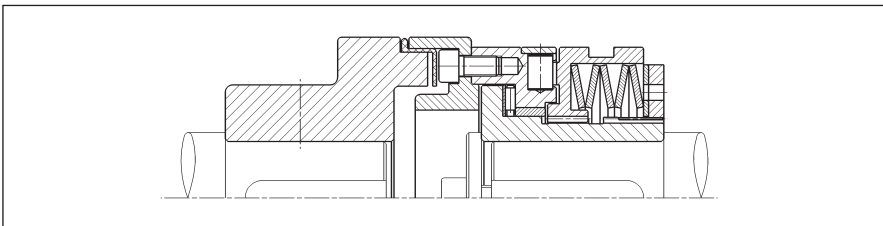

For flexible connection of two shafts. The flexible elements are oil-proof.

Page 29

## Notes

### Torque setting

The limit torque can be set at the factory on request. Setting or modification of the limit torque can also be carried out by the customer. See operating instructions for further details.

### Proximity switch

An overload can be indicated by a non-contact or a mechanical proximity switch. Further details on pages 60 and 61.

### Speed Control ESC

The RINGSPANN speed control ESC (Electronic Speed Control) monitors speed deviations and speed differences safely and also under difficult operating conditions. See catalogue 50.1 for details.

# Synchronous Ratcheting SIKUMAT

## with single cylindrical rollers

### Series SN - flange design

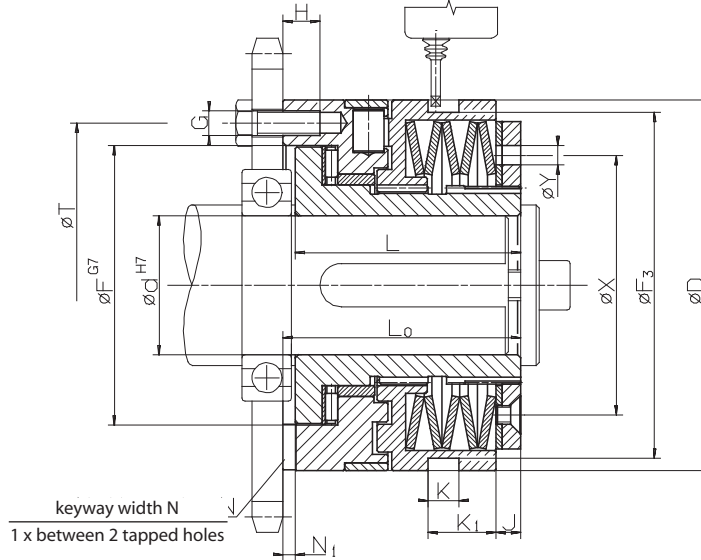

Z = number of tapped holes G on pitch circle T · Installation must be shut down as soon as torque limiter responds

## Technical Data

type	art. no.	torque type 1			torque type 2			torque type 3		
		limit torque Nm	max. speed min <sup>-1</sup>	end no.	limit torque Nm	max. speed min <sup>-1</sup>	end no.	limit torque Nm	max. speed min <sup>-1</sup>	end no.
SN 32.x	4470.020.xxx	5 - 10	1000	801	10 - 20	1000	802	20 - 40	500	803
SN 40.x	4470.025.xxx	12 - 25	950	801	25 - 50	950	802	50 - 100	450	803
SN 55.x	4470.035.xxx	25 - 50	800	801	50 - 100	800	802	100 - 200	400	803
SN 65.x	4470.045.xxx	50 - 100	650	801	100 - 200	650	802	200 - 450	300	803
SN 80.x	4470.055.xxx	100 - 200	550	801	200 - 400	550	802	400 - 800	250	803
SN 90.x	4470.065.xxx	170 - 450	400	801	350 - 900	400	802	600 - 1800	150	803

## Dimensions

Type	Référence	bore d		D	F	F <sub>3</sub>	G	H	J	K	K <sub>1</sub>	L	L <sub>0</sub>	N	N <sub>1</sub>	T	X	Y	Z	Course active
		min. mm	max. mm																	
SN 32.x	4470.020.xxx	7	20	55	41	50	M5	6,5	3	9	13,5	35	38,5	6	3,1	48	38,5	5	6	1,2
SN 40.x	4470.025.xxx	10	25	82	60	72,5	M5	8	6	9	14,5	48	52	6	3,1	70	54	6	6	1,8
SN 55.x	4470.035.xxx	14	35	100	78	90,5	M6	10	6	9	15	56	61	8	3,6	89	70	6	6	2,0
SN 65.x	4470.045.xxx	18	45	120	90,5	112	M8	12	8,5	10	22,5	72	78	10	4,1	105	84	6	6	2,2
SN 80.x	4470.055.xxx	24	55	146	105	140	M10	15	11	9	25	93,5	100	12	4,1	125	108	7	6	2,5
SN 90.x	4470.065.xxx	30	70 <sup>1)</sup>	176	120,5	170	M12	17	12	9	30	107	113,5	14	4,6	155	129	10	6	3,0

Keyway as per DIN 6885, page 1 · Tolerance of keyway width JS9

<sup>1)</sup> Keyway as per DIN 6885, page 3 · Tolerance of keyway width JS9

## Example for Ordering

please indicate when ordering:	type	art. no.	preset limit torque	bore d	with proximity switch
	SN 32. 3	4470.020. 803	30 Nm	9 mm	see p.60 and 61

torque type  end no.

# Synchronous Ratcheting SIKUMAT

with single rollers

Series SNR - with short hub and integral needle bearing

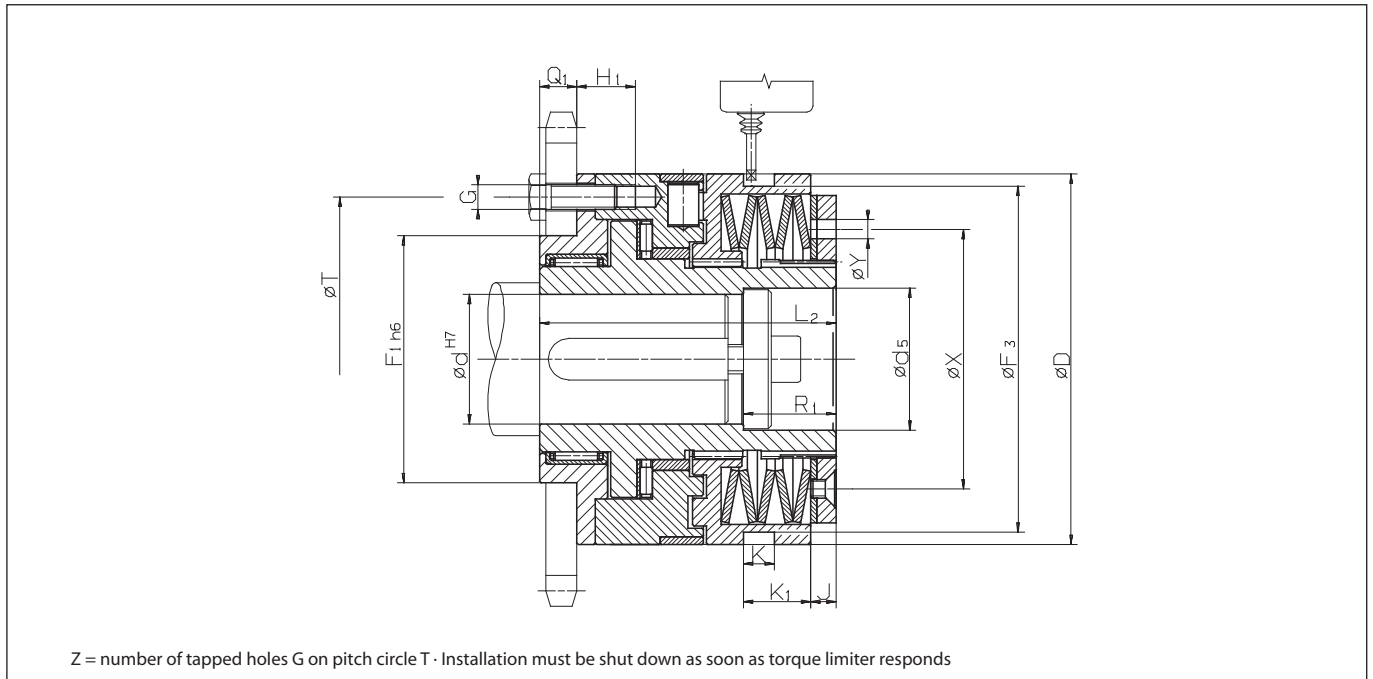

## Technical Data

type	art. no.	torque type 1			torque type 2			torque type 3		
		limit torque Nm	max. speed min <sup>-1</sup>	end no.	limit torque Nm	max. speed min <sup>-1</sup>	end no.	limit torque Nm	max. speed min <sup>-1</sup>	end no.
SNR 32.x	4470.920.xxx	5 - 10	1000	801	10 - 20	1000	802	20 - 40	500	803
SNR 40.x	4470.925.xxx	12 - 25	950	801	25 - 50	950	802	50 - 100	450	803
SNR 55.x	4470.935.xxx	25 - 50	800	801	50 - 100	800	802	100 - 200	400	803
SNR 65.x	4470.945.xxx	50 - 100	650	801	100 - 200	650	802	200 - 450	300	803
SNR 80.x	4470.955.xxx	100 - 200	550	801	200 - 400	550	802	400 - 800	250	803
SNR 90.x	4470.965.xxx	170 - 450	400	801	350 - 900	400	802	600 - 1800	150	803

## Dimensions

Type	Référence	bore d		d <sub>5</sub>	D	F <sub>1</sub>	F <sub>3</sub>	G	H <sub>1</sub>	J	K	K <sub>1</sub>	L <sub>2</sub>	Q <sub>1</sub>	R <sub>1</sub>	T	X	Y	Z	Course active
		min. mm	max. mm																	
SNR 32.x	4470.920.xxx	7	20	21	55	38	50	M5	11,5	3	9	13,5	51,5	8	15	48	38,5	5	6	1,2
SNR 40.x	4470.925.xxx	10	25	26	82	50	72,5	M5	16	6	9	14,5	70	10	20	70	54	6	6	1,8
SNR 55.x	4470.935.xxx	14	35	36	100	60	90,5	M6	15	6	9	15	78	12	25	89	70	6	6	2,0
SNR 65.x	4470.945.xxx	18	45	46	120	80	112	M8	18	8,5	10	22,5	96	12	30	105	84	6	6	2,2
SNR 80.x	4470.955.xxx	24	55	56	146	100	140	M10	23,5	11	9	25	124,5	16	30	125	108	7	6	2,5
SNR 90.x	4470.965.xxx	30	70 <sup>1)</sup>	66	176	120	170	M12	25,5	12	9	30	140	18	30	155	129	10	6	3,0

Keyway as per DIN 6885, page 1 · Tolerance of keyway width JS9

<sup>1)</sup> Keyway as per DIN 6885, page 3 · Tolerance of keyway width JS9

## Example for Ordering

please indicate when ordering:	type	art. no.	preset limit torque	bore d	with proximity switch
	SNR 32. 2	4470.920. 802	15 Nm	13 mm	see p. 60 and 61

torque type  end no.

# Synchronous Ratcheting SIKUMAT

## with single rollers

### Series SNG - with long hub

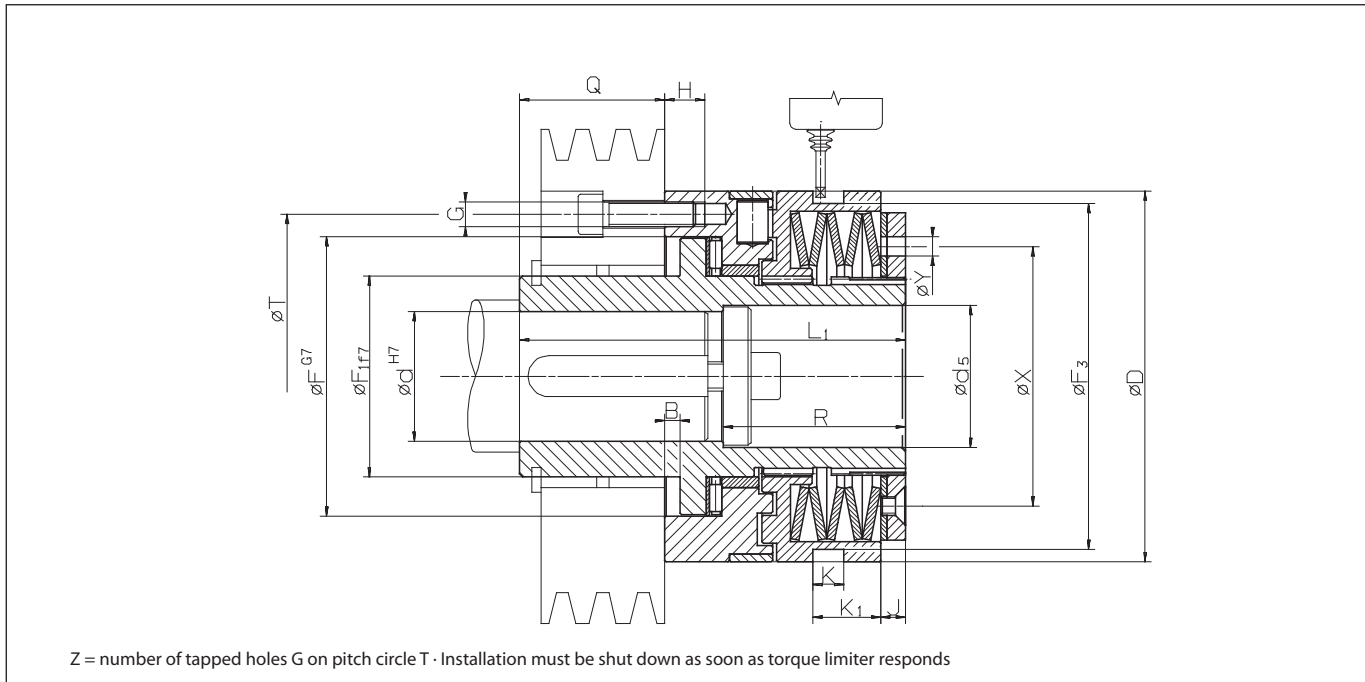

## Technical Data

type	art. no.	torque type 1			torque type 2			torque type 3		
		limit torque Nm	max. speed min <sup>-1</sup>	end no.	limit torque Nm	max. speed min <sup>-1</sup>	end no.	limit torque Nm	max. speed min <sup>-1</sup>	end no.
SNG 32.x	4470.120.xxx	5 - 10	1000	801	10 - 20	1000	802	20 - 40	500	803
SNG 40.x	4470.125.xxx	12 - 25	950	801	25 - 50	950	802	50 - 100	450	803
SNG 55.x	4470.135.xxx	25 - 50	800	801	50 - 100	800	802	100 - 200	400	803
SNG 65.x	4470.145.xxx	50 - 100	650	801	100 - 200	650	802	200 - 450	300	803
SNG 80.x	4470.155.xxx	100 - 200	550	801	200 - 400	550	802	400 - 800	250	803
SNG 90.x	4470.165.xxx	170 - 450	400	801	350 - 900	400	802	600 - 1800	150	803

## Dimensions

Type	Référence	bore d		d <sub>5</sub>	B	D	F	F <sub>1</sub>	F <sub>3</sub>	G	H	J	K	K <sub>1</sub>	L <sub>1</sub>	Q	R	T	X	Y	Z	Course active
		min. mm	max. mm																			
SNG 32.x	4470.120.xxx	7	20	21	4	55	41	28	50	M5	6,5	3	9	13,5	66	27,5	25,5	48	38,5	5	6	1,2
SNG 40.x	4470.125.xxx	10	25	26	4	82	60	38	72,5	M5	8	6	9	14,5	83	33	35	70	54	6	6	1,8
SNG 55.x	4470.135.xxx	14	35	36	5	100	78	52	90,5	M6	10	6	9	15	100	39	45	89	70	6	6	2,0
SNG 65.x	4470.145.xxx	18	45	46	5	120	90,5	65	112	M8	12	8,5	10	22,5	125	47	59	105	84	6	6	2,2
SNG 80.x	4470.155.xxx	24	55	56	6,5	146	105	78	140	M10	15	11	9	25	152,5	52,5	60	125	108	7	6	2,5
SNG 90.x	4470.165.xxx	30	70 <sup>1)</sup>	66	6,5	176	120,5	90	170	M12	17	12	9	30	171	57,5	60	155	129	10	6	3,0

Keyway as per DIN 6885, page 1 · Tolerance of keyway width JS9

<sup>1)</sup> Keyway as per DIN 6885, page 1 · Tolerance of keyway width JS9

## Example for Ordering

please indicate when ordering:	type	art. no.	preset limit torque	bore d	with proximity switch
	SNG 32. 2	4470.120. 802	15 Nm	10 mm	see p.60 and 61

torque type  end no.

# Synchronous Ratcheting SIKUMAT

with single rollers

Series SNE - with flexible shaft coupling

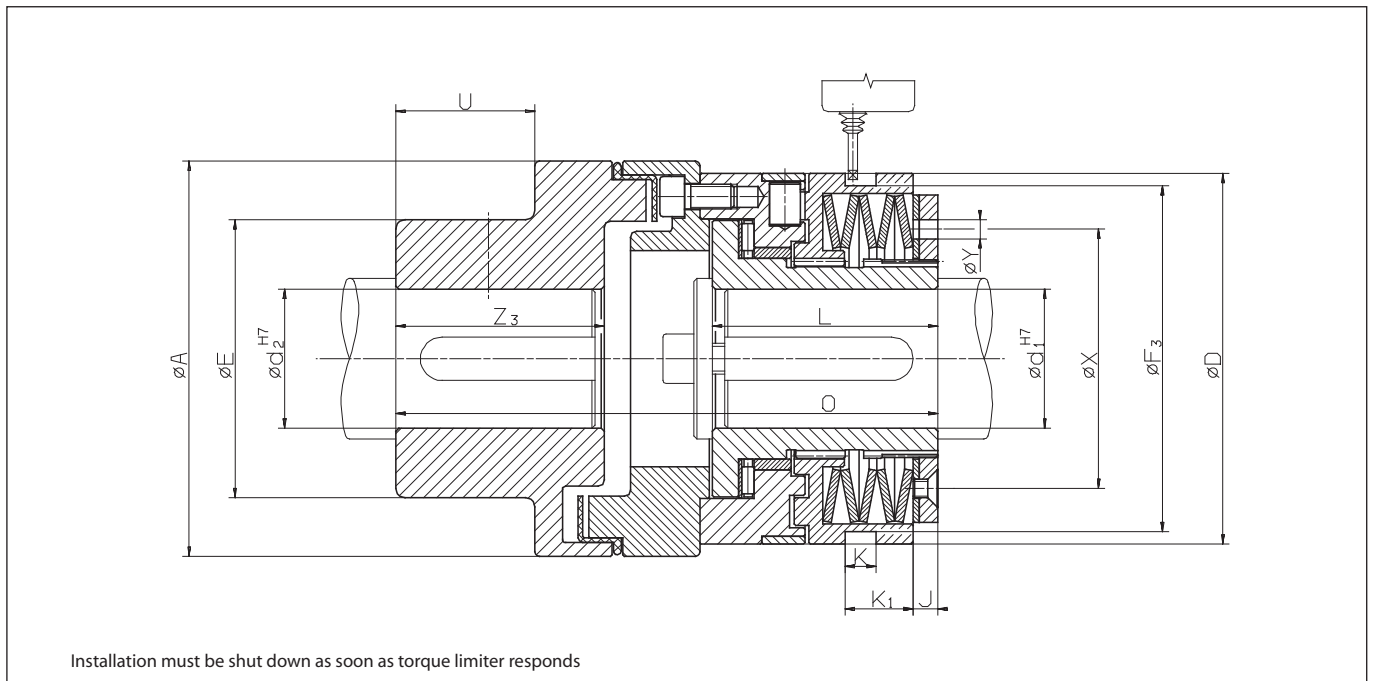

## Technical Data

type	art. no.	torque type 1			torque type 2			torque type 3		
		limit torque Nm	max. speed min <sup>-1</sup>	end no.	limit torque Nm	max. speed min <sup>-1</sup>	end no.	limit torque Nm	max. speed min <sup>-1</sup>	end no.
SNE 32.x	4470.620.xxx	5 - 10	1000	801	10 - 20	1000	802	20 - 40	500	803
SNE 40.x	4470.625.xxx	12 - 25	950	801	25 - 50	950	802	50 - 100	450	803
SNE 55.x	4470.635.xxx	25 - 50	800	801	50 - 100	800	802	100 - 200	400	803
SNE 65.x	4470.645.xxx	50 - 100	650	801	100 - 200	650	802	200 - 450	300	803
SNE 80.x	4470.655.xxx	100 - 200	550	801	200 - 400	550	802	400 - 800	250	803
SNE 90.x	4470.665.xxx	170 - 450	400	801	350 - 900	400	802	600 - 1800	150	803

## Dimensions

Type	Référence	bore d <sub>1</sub>		d <sub>2</sub>	A	E	D	F <sub>3</sub>	J	K	K <sub>1</sub>	L	O	U	X	Y	Z <sub>3</sub>	Course active
		min. mm	max. mm															
SNE 32.x	4470.620.xxx	7	20	30	67	46	55	50	3	9	13,5	35	86	15	38,5	5	28	1,2
SNE 40.x	4470.625.xxx	10	25	50	112	79	82	72,5	6	9	14,5	48	137,5	38	54	6	58	1,8
SNE 55.x	4470.635.xxx	14	35	50	112	79	100	90,5	6	9	15	56	147	38	70	6	58	2,0
SNE 65.x	4470.645.xxx	18	45	60	128	90	120	112	8,5	10	22,5	72	176,5	45	84	6	67	2,2
SNE 80.x	4470.655.xxx	24	55	60	148	90	146	140	11	9	25	93,5	211,5	45	108	7	67	2,5
SNE 90.x	4470.665.xxx	30	70 <sup>1)</sup>	70	177	107	176	170	12	9	30	107	242,5	52	129	10	75	3,0
SNE 90.x	4470.665.xxx	30	70 <sup>1)</sup>	90	198	140	176	170	12	9	30	107	272	52	129	10	75	3,0

Keyway as per DIN 6885, page 1 · Tolerance of keyway width JS9

<sup>1)</sup> Keyway as per DIN 6885, page 1 · Tolerance of keyway width JS9

## Example for Ordering

please indicate when ordering:	type	art. no.	preset limit torque	bore d <sub>1</sub>	bore d <sub>2</sub>	with proximity switch
		SNE 32. 2	4470.620. 802	15 Nm	10 mm	20 mm

torque type  end no.

# Synchronous Ratcheting SIKUMAT with double rollers

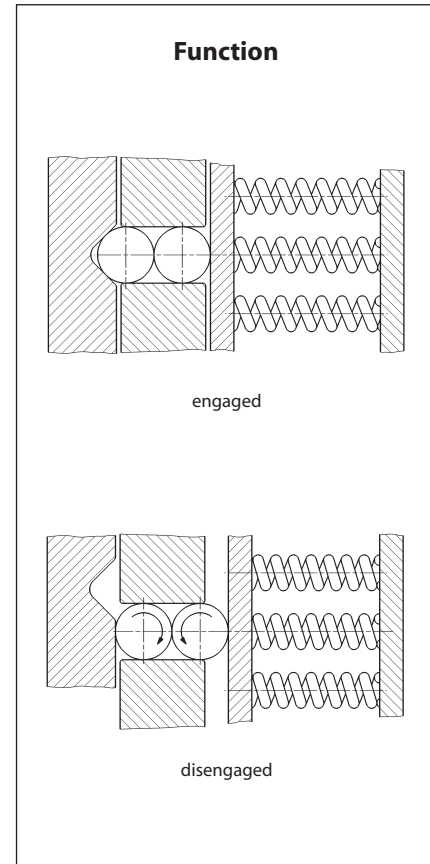
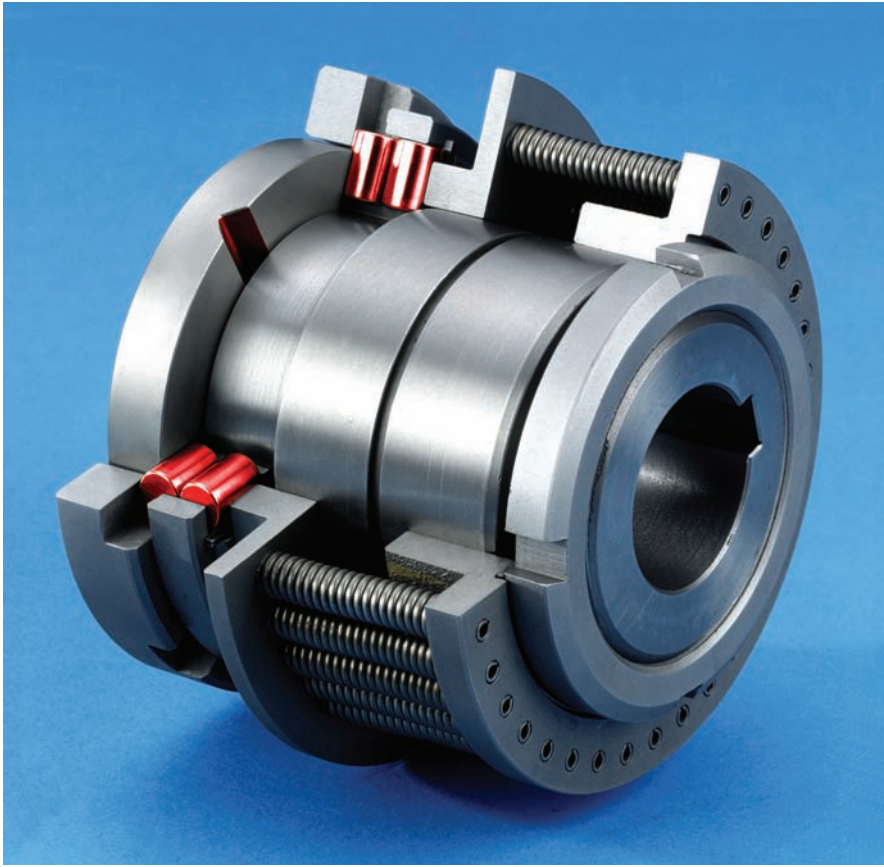

## The Double Roller Principle

The torque is transmitted via six pairs of rollers which are pressed by coil springs into detents. When the preset limit torque has been reached, the rollers move against the spring force up the sloping surface and disengage. This characteristic combined with the particular geometry of the detents provide a high degree of consistency to the limit torque of the SIKUMAT over the duration of the operating period. Re-engagement is effected synchronously after 360° due to the asymmetrical division of the detents.

## Advantages

- High degree of consistency of limit torque over the duration of operation through double roller principle
- Synchronous re-engagement after 360°
- Torques up to 10 000 Nm
- For shaft diameters up to 125 mm
- Protection against unauthorised adjustment of the limit torque

## Function

- When the preset limit torque has been reached the SIKUMAT ratchets.
- Following elimination of overload automatic synchronous re-engagement of the SIKUMAT to the starting position after 360°.
- The overload can be indicated by a proximity switch. This means that the drive can be switched off immediately or another control function can be activated.

# Synchronous Ratcheting SIKUMAT with double rollers

## Types

### Series SA - flange design

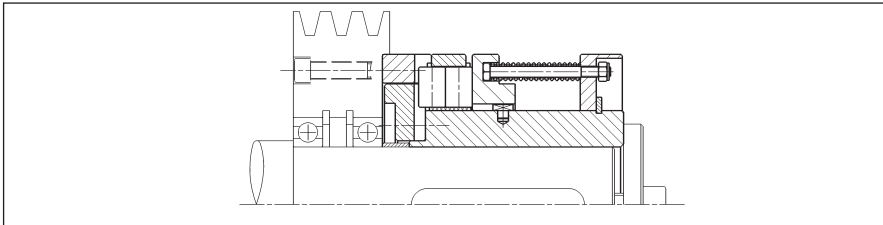

For attaching chain wheels, belt pulleys, gear wheels etc. Bearing of attached component on the shaft to be provided by the customer.

Page 32

### Series SAG - with long hub

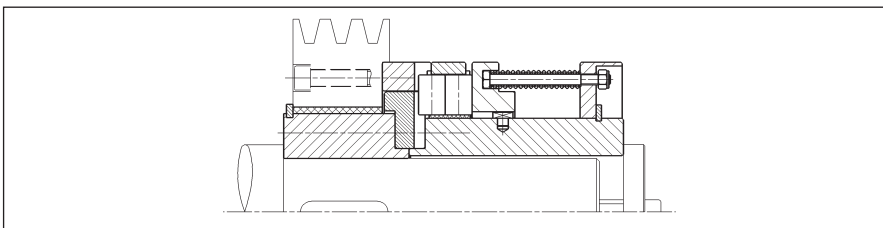

With long hub for wide components. Plain bearings are included in delivery.

Page 33

### Series SAE - with flexible shaft coupling

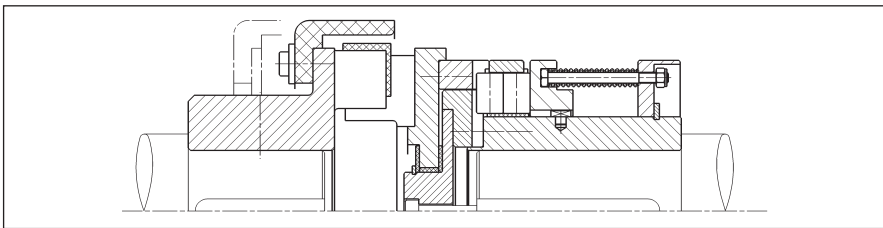

For flexible connection of two shafts. The flexible elements are oil-proof.

Page 34

### Series SAL - with torsionally rigid shaft coupling

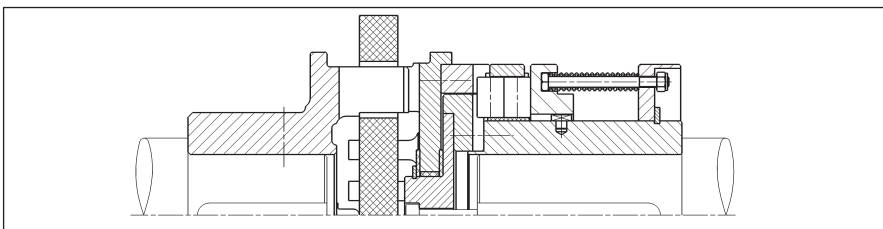

For torsionally rigid connection of two shafts. Possibility to compensate for large radial and angular displacements.

Page 35

## Notes

### Torque setting

The limit torque is normally set at the factory. Setting or modification of the limit torque can also be carried out by the customer but no unauthorised adjustment should be carried out by the machine operator. See operating instructions for further details.

### Proximity switch

The overload can be indicated by a non-contact or a mechanical proximity switch. Further details on pages 60 and 61.

### Speed Control ESC

The RINGSPANN speed control ESC (Electronic Speed Control) monitors speed deviations and speed differences safely and also under difficult operating conditions. See catalogue 50.1 for details.

# Synchronous Ratcheting SIKUMAT

## with double rollers

### Series SA - flange design

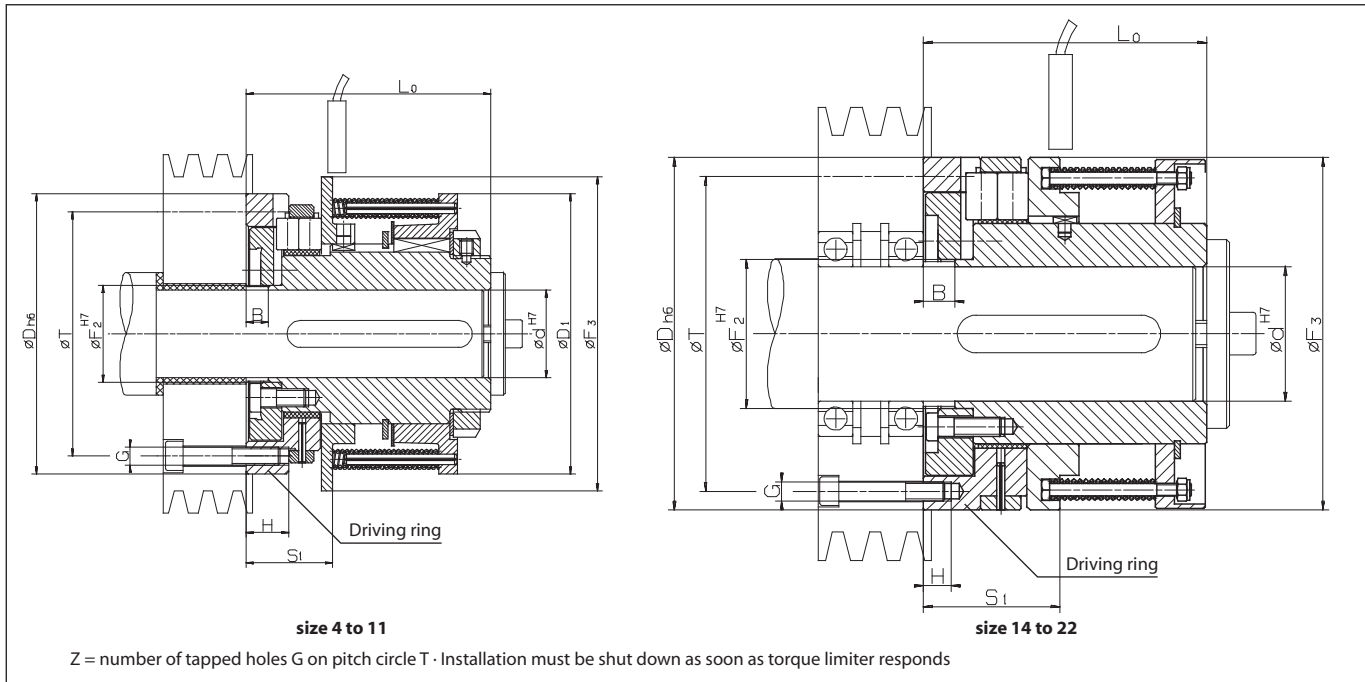

#### Technical Data

type	art. no.	limit torque	max. speed
		Nm	min <sup>-1</sup>
SA 4	4470.004.800	7 - 80	1500
SA 7	4470.007.800	26 - 310	800
SA 11	4470.011.800	105 - 1250	500
SA 14	4470.014.800	210 - 2500	400
SA 18	4470.018.800	420 - 5000	315
SA 22	4470.022.800	840 - 10000	250

#### Dimensions

Type	Référence	bore d		B	D	D <sub>1</sub>	F <sub>2</sub>	F <sub>3</sub>	G	H	L <sub>0</sub>	S <sub>1</sub>	T	Z	Course active
		min. mm	max. mm												
SA 4	4470.004.800	9	25	8	80	80	27	90	M6	11	71	24	71	3	1,6
SA 7	4470.007.800	25	40	10	125	125	43	140	M8	19	109	38	109	3	2,5
SA 11	4470.011.800	30	65	15	180	200	75	212	M10	16	175	61	160	6	4,0
SA 14	4470.014.800	50	80	20	224	-	95	224	M12	18	180	87	200	6	5,0
SA 18	4470.018.800	65	100	24	280	-	118	280	M16	25	224	110	250	6	6,2
SA 22	4470.022.800	80	125	30	355	-	150	355	M20	30	280	140	315	6	8,0

Keyway as per DIN 6885, page 1 · Tolerance of keyway width P9

#### Example for Ordering

please indicate when ordering:	type	art. no.	preset limit torque	bore d	with proximity switch
		SA 4	4470.004.800	9 Nm	12 mm





# Synchronous Ratcheting SIKUMAT

## with double rollers

### Series SAE - with flexible shaft coupling

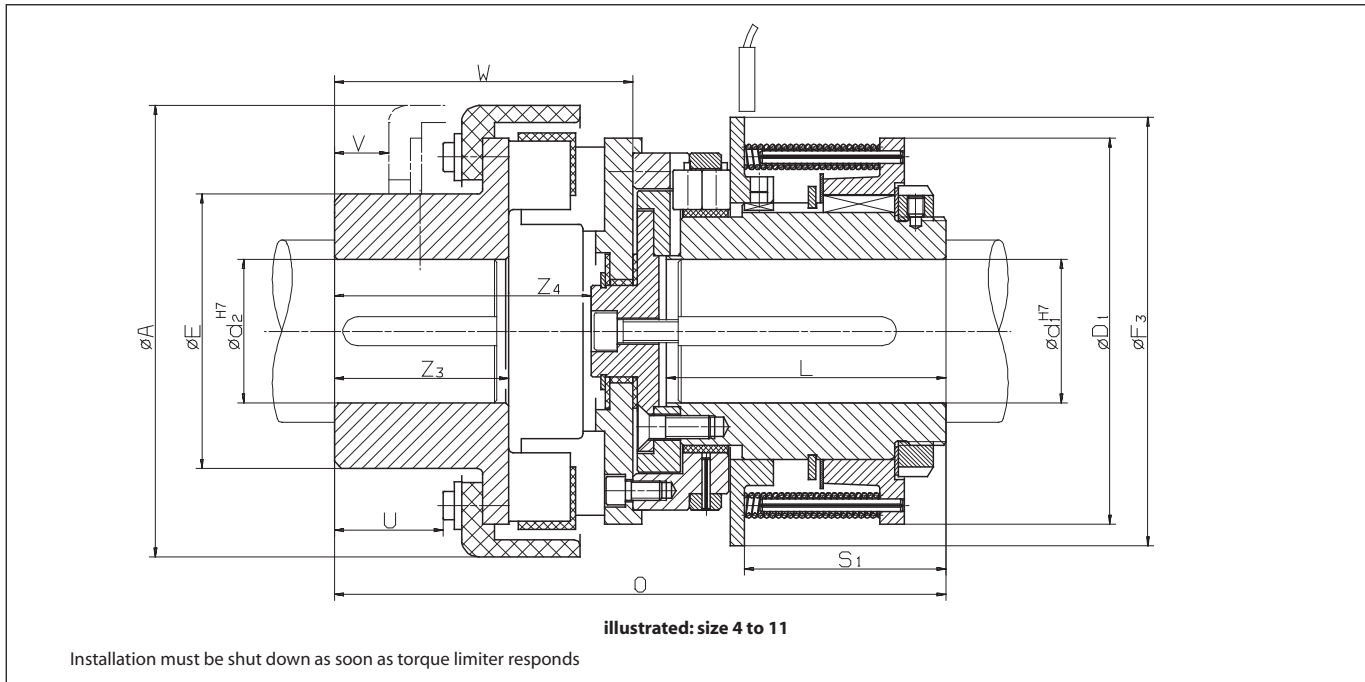

### Technical Data

type	art. no.	limit torque	max. speed
		Nm	min <sup>-1</sup>
SAE 4	4470.604.800	7 - 80	1500
SAE 7	4470.607.800	26 - 310	800
SAE 11	4470.611.800	105 - 1250	500
SAE 14	4470.614.800	210 - 2500	400
SAE 18	4470.618.800	420 - 5000	315
SAE 22	4470.622.800	840 - 10000	250

### Dimensions

Type	Référence	bore d <sub>1</sub>		bore d <sub>2</sub>		A	D <sub>1</sub>	F <sub>3</sub>	E	L	O	S <sub>1</sub>	U	V	W	Z <sub>3</sub>	Z <sub>4</sub>	Course active
		min. mm	max. mm	min. mm	max. mm													
SAE 4	4470.604.800	9	25	5	45	114	80	90	72	63	146	47	28	19	75	41	63	1,6
SAE 7	4470.607.800	25	40	20	60	158	125	140	96	99	221	71	39	21	112	61	97	2,5
SAE 11	4470.611.800	30	65	25	80	230	180	212	130	160	318	114	49	21	143	82	124	4,0
SAE 14	4470.614.800	50	80	45	100	294	224	224	160	160	359	93	56	17	179	97	153	5,0
SAE 18	4470.618.800	65	100	60	120	330	280	280	195	200	430	114	80	25	206	116	179	6,2
SAE 22	4470.622.800	80	125	75	160	432	355	355	255	250	563	140	104	31	283	160	247	8,0

Keyway as per DIN 6885, page 1 - Tolerance of keyway width P9

### Example for Ordering

please indicate when ordering:	type	art. no.	preset limit torque	bore d <sub>1</sub>	bore d <sub>2</sub>	with proximity switch
		SAE 4	4470.604.800	40 Nm	29 mm	40 mm

# Synchronous Ratcheting SIKUMAT

## with double rollers

### Series SAL - with torsionally rigid shaft coupling

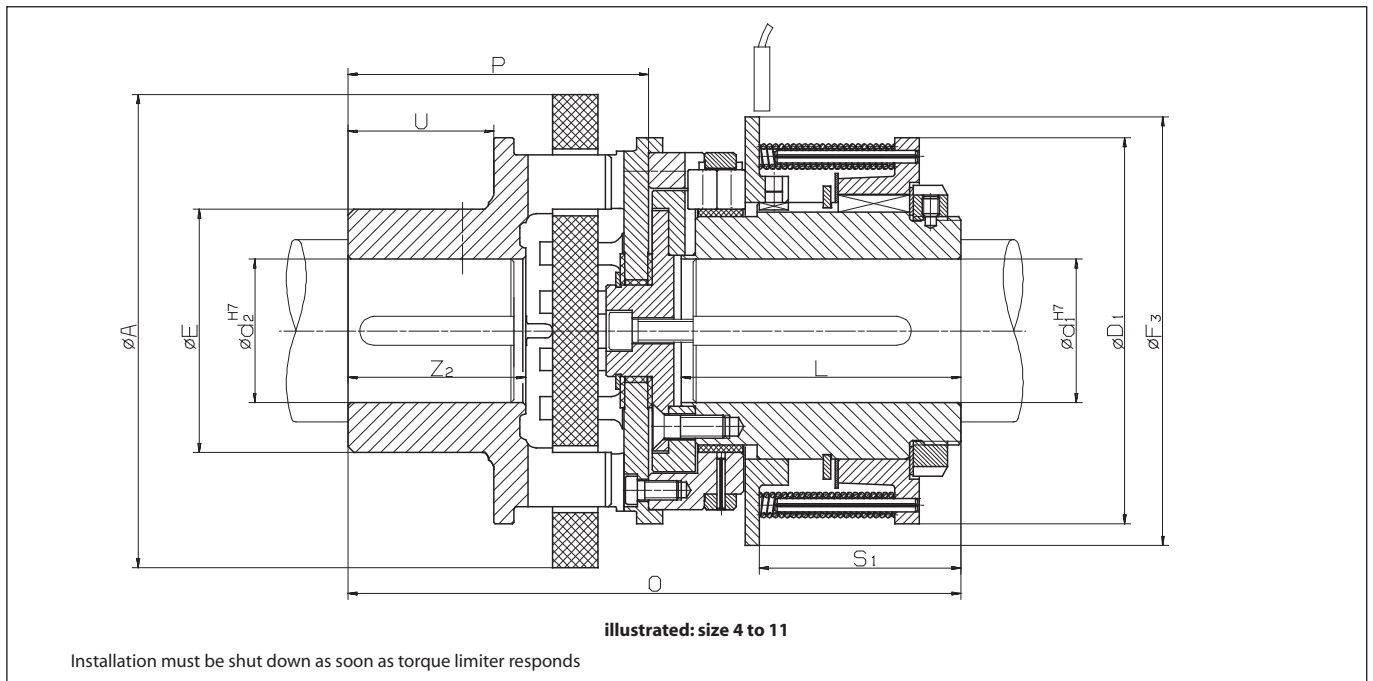

#### Technical Data

type	art. no.	limit torque		max. speed
		Nm		
SAL 4	4470.404.800	7 -	80	1500
SAL 7	4470.407.800	26 -	310	800
SAL 11	4470.411.800	105 -	1250	500
SAL 14	4470.414.800	210 -	2500	400
SAL 18	4470.418.800	420 -	5000	315
SAL 22	4470.422.800	840 -	10000	250

#### Dimensions

Type	Référence	bore d <sub>1</sub>		bore d <sub>2</sub>		A	D <sub>1</sub>	E	F <sub>3</sub>	L	O	P	U	S <sub>1</sub>	Z <sub>2</sub>	Course active
		min. mm	max. mm	min. mm	max. mm											
SAL 4	4470.404.800	9	25	16	35	110	80	53	90	63	148	77	33	47	42	1,6
SAL 7	4470.407.800	25	40	30	50	160	125	85	140	99	214	105	51	71	62	2,5
SAL 11	4470.411.800	30	65	50	90	250	200	150	212	160	335	160	81	114	100	4,0
SAL 14	4470.414.800	50	80	60	110	315	224	175	224	160	384	204	101	93	124	5,0
SAL 18	4470.418.800	65	100	60	110	315	280	175	280	200	462	238	101	114	124	6,2
SAL 22	4470.422.800	80	125	75	140	400	355	216	355	250	600	320	130	140	160	8,0

Permissible radial displacement 0,015 x ØA · Permissible angular displacement max. 3°  
Keyway as per DIN 6885, page 1 · Tolerance of keyway width P9

#### Example for Ordering

please indicate when ordering:	type	art. no.	preset limit torque	bore d <sub>1</sub>	bore d <sub>2</sub>	with proximity switch
		SAL 4	4470.404.800	13 Nm	13 mm	17 mm

# Synchronous Ratcheting SIKUMAT - Backlash free with balls

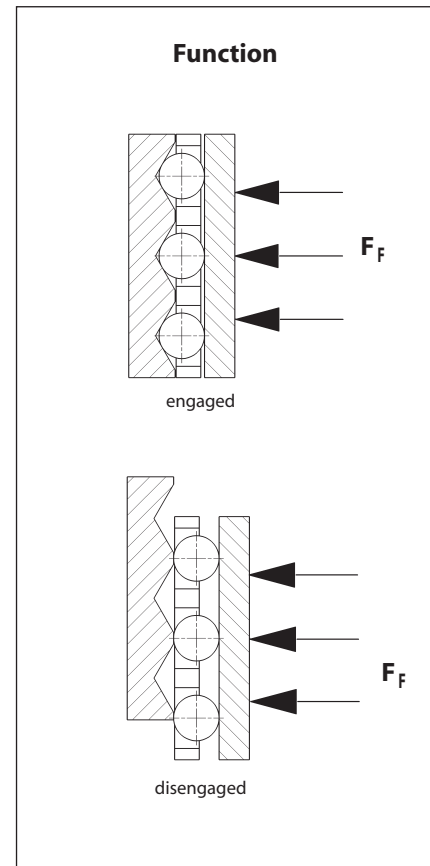

## The Ball Principle

The torque is transmitted via balls which are pressed by Belleville springs into v-shaped grooves. The grooves are arranged axially on the output side and radially on the input side, which means that torque can be transmitted backlash free in both directions of rotation. When the preset limit torque has been reached, the groove-ring is displaced. Due to the unsymmetrical division of the grooves, re-engagement is effected synchronously after 360°, as soon as the overload has been eliminated. The negative characteristic disc springs give extremely fast, accurate and consistent overload protection.

## Advantages

- Backlash free in both directions of rotation
- Compact design
- Integral ball bearing for supporting the component to be connected
- Very high response accuracy through the ball principle
- Simple and backlash free fastening onto shaft with integral cone clamping element
- Calibrated micro adjustment of torque setting possible, even post-installation
- Exchange of current torque limiters possible

## Function

- When the preset limit torque has been reached the SIKUMAT ratchets through.
- Following elimination of overload automatic synchronous re-engagement of the SIKUMAT to the starting position after 360°.
- The overload can be indicated by a proximity switch. This means that the drive can be switched off immediately or another control function can be activated.

# Synchronous Ratcheting SIKUMAT - Backlash free with balls

## Types

### Series SU - flange design

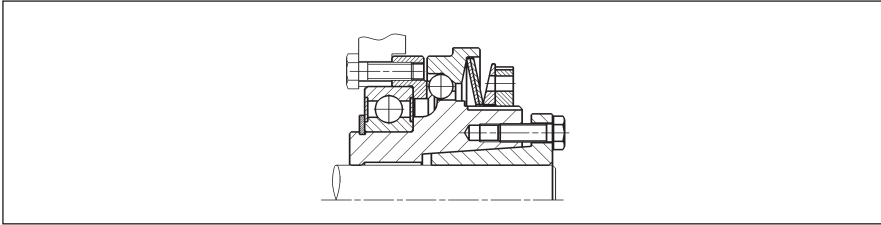

For attaching chain wheels, belt pulleys, gear wheels etc. Support of the component to be connected directly on the integral ball bearing.

Page 38

### Series SUG - with long hub

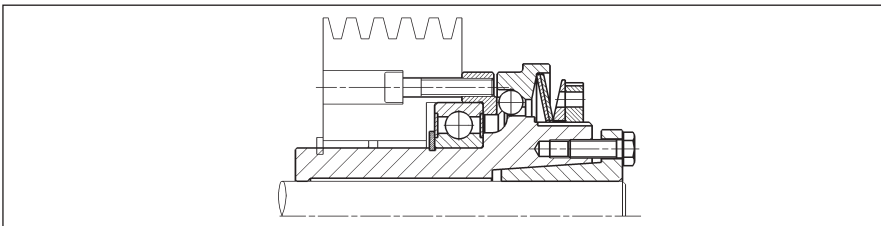

With long hub for wide components to be connected. Support of the component to be connected directly on the integral ball bearing; additional radial bearing to be provided by the customer.

Page 39

### Series SUE - with flexible shaft coupling

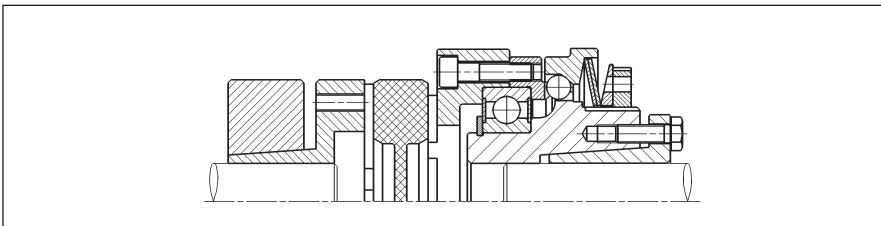

For flexible connection of two shafts.

Page 40

### Series SUL - with torsionally rigid shaft coupling

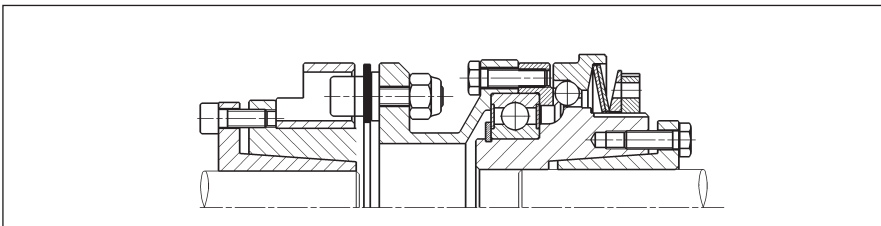

For rigid connection of two shafts.

Page 41

## Notes

### Torque setting

The limit torque can be set at the factory on request. Setting or modification of the limit torque can also be carried out by the customer. See operating instructions for further details.

### Proximity switch

An overload can be indicated by a non-contact or a mechanical proximity switch. Further details on pages 60 and 61.

### Keyway design

Types SU and SUG with bore and keyway are available on request.

### Speed Control ESC

The RINGSPANN speed control ESC (Electronic Speed Control) monitors speed deviations and speed differences safely and also under difficult operating conditions. See catalogue 50.1 for details.

# Synchronous Ratcheting SIKUMAT - Backlash free with balls

## Series SU - flange design

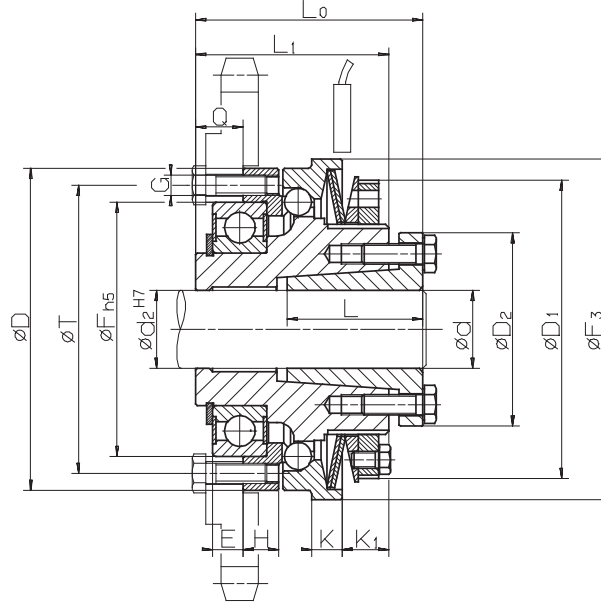

Z = number of tapped holes G on pitch circle T · Installation must be shut down as soon as torque limiter responds

### Technical Data

type	art. no.	torque type 1			torque type 2			torque type 3		
		limit torque Nm	max. speed min <sup>-1</sup>	end no.	limit torque Nm	max. speed min <sup>-1</sup>	end no.	limit torque Nm	max. speed min <sup>-1</sup>	end no.
SU 30.x	4479.025.xxx	5 - 14	4000	101	10 - 28	4000	102	20 - 60	4000	103
SU 40.x	4479.030.xxx	9 - 27	3000	101	18 - 54	3000	102	38 - 115	3000	103
SU 45.x	4479.040.xxx	19 - 60	2500	101	38 - 125	2500	102	70 - 255	2500	103
SU 55.x	4479.050.xxx	35 - 110	2000	101	80 - 220	2000	102	160 - 440	2000	103
SU 65.x	4479.060.xxx	80 - 185	1200	101	160 - 370	1200	102	320 - 740	1200	103

### Dimensions

Type	Référence	bore d*		D	D <sub>1</sub>	D <sub>2</sub>	E	F	F <sub>3</sub>	G	H	K	K <sub>1</sub>	L	L <sub>0</sub>	L <sub>1</sub>	Q	T	Z	Course active
		min. mm	max. mm																	
SU 30.x	4479.025.xxx	10	20	65	63	40,5	5	47	70	M4	7,5	7	12	26	47	40	8	56	8	1,2
SU 30.x	4479.025.xxx	19	25	65	63	42	5	47	70	M4	7,5	7	12	26	47	40	8	56	8	1,2
SU 40.x	4479.030.xxx	15	30	80	77	57	7	62	85	M5	8	8	12	31	56	46	11	71	8	1,5
SU 45.x	4479.040.xxx	19	30	95	88	57	9	75	100	M6	10,5	9	14	40	67	57	14	85	8	1,8
SU 45.x	4479.040.xxx	32	40	95	88	64	9	75	100	M6	10,5	9	14	31	67	57	14	85	8	1,8
SU 55.x	4479.050.xxx	32	50	110	100	73,5	10	90	115	M6	12	10	16	29	73	63	16	100	8	2,0
SU 65.x	4479.060.xxx	32	50	130	122	73,5	10	100	135	M8	12	12	21	29	85	75	18	116	8	2,2
SU 65.x	4479.060.xxx	55	60	130	122	89	10	100	135	M8	12	12	21	45,5	86	75	18	116	8	2,2

Hub bore diameter d<sub>2</sub> is equal to the selected diameter d and serves as an additional centering guide.

\*Available bore diameters d: 10, 11, 12, 14, 15, 16, 18, 19, 20, 22, 24, 25, 28, 30, 32, 35, 38, 40, 42, 45, 48, 50, 55 and 60 mm.

### Example for Ordering

please indicate when ordering:	type	art. no.	preset limit torque	bore d	with proximity switch
	SU 40. 2	4479.030. 102	25 Nm	20 mm	see p.60 and 61

torque type  end no.

# Synchronous Ratcheting SIKUMAT - Backlash free with balls

## Series SUG - with long hub

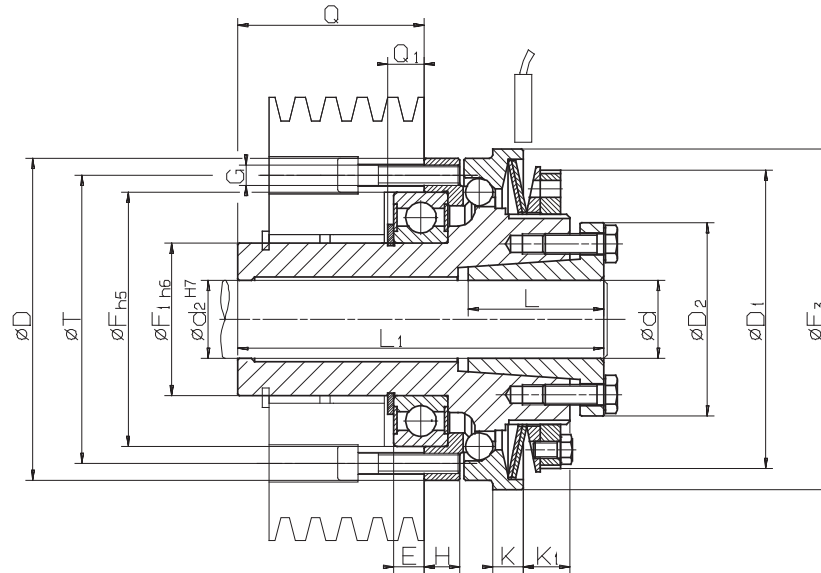

Z = number of tapped holes G on pitch circle T · Installation must be shut down as soon as torque limiter responds

### Technical Data

type	art. no.	torque type 1			torque type 2			torque type 3		
		limit torque Nm	max. speed min <sup>-1</sup>	end no.	limit torque Nm	max. speed min <sup>-1</sup>	end no.	limit torque Nm	max. speed min <sup>-1</sup>	end no.
SUG 30.x	4479.125.xxx	5 - 14	4000	101	10 - 28	4000	102	20 - 60	4000	103
SUG 40.x	4479.130.xxx	9 - 27	3000	101	18 - 54	3000	102	38 - 115	3000	103
SUG 45.x	4479.140.xxx	19 - 60	2500	101	38 - 125	2500	102	70 - 255	2500	103
SUG 55.x	4479.150.xxx	35 - 110	2000	101	80 - 220	2000	102	160 - 440	2000	103
SUG 65.x	4479.160.xxx	80 - 185	1200	101	160 - 370	1200	102	320 - 740	1200	103

### Dimensions

Type	Référence	bore d*		D	D <sub>1</sub>	D <sub>2</sub>	E	F	F <sub>1</sub>	F <sub>3</sub>	G	H	K	K <sub>1</sub>	L	L <sub>1</sub>	Q	Q <sub>1</sub>	T	Z	Course active
		min. mm	max. mm																		
SUG 30.x	4479.125.xxx	10	20	65	63	40,5	5	47	30	70	M4	7,5	7	12	26	72	33	6,5	56	8	1,2
SUG 30.x	4479.125.xxx	19	25	65	63	42	5	47	30	70	M4	7,5	7	12	26	72	33	6,5	56	8	1,2
SUG 40.x	4479.130.xxx	15	30	80	77	57	7	62	40	85	M5	8	8	12	31	88	43	8,75	71	8	1,5
SUG 45.x	4479.140.xxx	19	30	95	88	57	9	75	45	100	M6	10,5	9	14	40	108	55	11,5	85	8	1,8
SUG 45.x	4479.140.xxx	32	40	95	88	64	9	75	45	100	M6	10,5	9	14	31	108	55	11,5	85	8	1,8
SUG 55.x	4479.150.xxx	32	50	110	100	73,5	10	90	55	115	M6	12	10	16	29	124	67	13	100	8	2,0
SUG 65.x	4479.160.xxx	32	50	130	122	73,5	10	100	65	135	M8	12	12	21	29	140	73	14	116	8	2,2
SUG 65.x	4479.160.xxx	55	60	130	122	89	10	100	65	135	M8	12	12	21	45,5	141	73	14	116	8	2,2

Diameter d<sub>2</sub> at the end of the long hub is equal to the selected diameter d and serves as an additional centering.

\*Available bore diameters d: 10, 11, 12, 14, 15, 16, 18, 19, 20, 22, 24, 25, 28, 30, 32, 35, 38, 40, 42, 45, 48, 50, 55 and 60 mm.

### Example for Ordering

please indicate when ordering:	type	art. no.	preset limit torque	bore d	with proximity switch
	SUG 65.1	4479.160. 101	90 Nm	60 mm	see p. 60 and 61

torque type  end no.

# Synchronous Ratcheting SIKUMAT - Backlash free with balls

## Series SUE - flexible shaft coupling

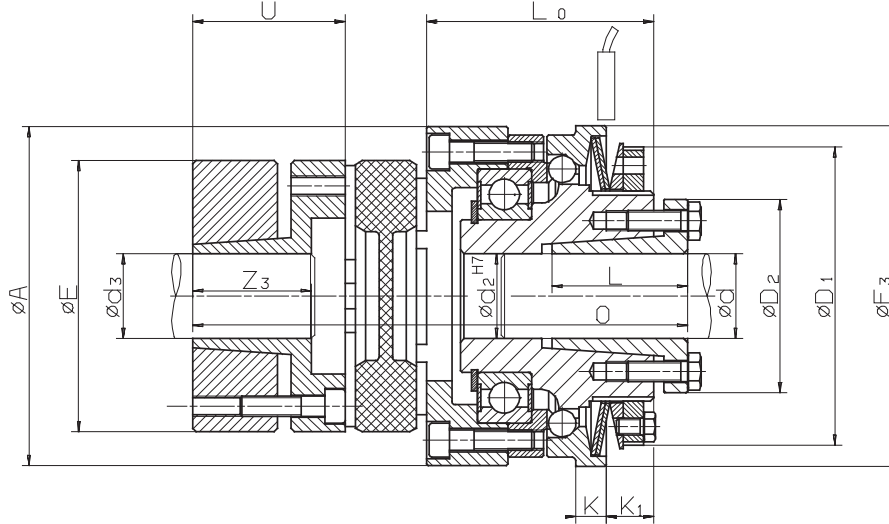

Installation must be shut down as soon as torque limiter responds

### Technical Data

type	art. no.	torque type 1			torque type 2			torque type 3		
		limit torque Nm	max. speed min <sup>-1</sup>	end no.	limit torque Nm	max. speed min <sup>-1</sup>	end no.	limit torque Nm	max. speed min <sup>-1</sup>	end no.
SUE 30.x	4479.625.xxx	5 - 14	4000	101	10 - 28	4000	102	20 - 60	4000	103
SUE 40.x	4479.630.xxx	9 - 27	3000	101	18 - 54	3000	102	38 - 115	3000	103
SUE 45.x	4479.640.xxx	19 - 60	2500	101	38 - 125	2500	102	70 - 255	2500	103
SUE 55.x	4479.650.xxx	35 - 110	2000	101	80 - 220	2000	102	160 - 440	2000	103
SUE 65.x	4479.660.xxx	80 - 185	1200	101	160 - 370	1200	102	320 - 740	1200	103

### Dimensions

Type	Référence	bore d*		bore d <sub>3</sub> **		A	D <sub>1</sub>	D <sub>2</sub>	E	F <sub>3</sub>	K	K <sub>1</sub>	L	L <sub>0</sub>	O	U	Z <sub>3</sub>	Course active
		min. mm	max. mm	min. mm	max. mm													
SUE 30.x	4479.625.xxx	10	20	15	28	70	63	40,5	55	70	7	12	26	47	102	30	30	1,2
SUE 30.x	4479.625.xxx	19	25	15	28	70	63	42	55	70	7	12	26	47	102	30	30	1,2
SUE 40.x	4479.630.xxx	15	30	15	38	85	77	57	65	85	8	12	31	54,5	119,5	35	35	1,5
SUE 45.x	4479.640.xxx	19	30	20	45	100	88	57	80	100	9	14	40	67	146	45	45	1,8
SUE 45.x	4479.640.xxx	32	40	20	45	100	88	64	80	100	9	14	31	67	146	45	45	1,8
SUE 55.x	4479.650.xxx	32	50	25	50	115	100	73,5	95	115	10	16	29	73	159	50	50	2,0
SUE 65.x	4479.660.xxx	32	50	30	55	135	122	73,5	105	135	12	21	29	87	182	56	56	2,2
SUE 65.x	4479.660.xxx	55	60	30	55	135	122	89	105	135	12	21	45,5	87	182	56	56	2,2

Hub bore diameter d<sub>2</sub> is equal to the selected diameter d and serves as an additional centering guide.

\*Available bore diameters d: 10, 11, 12, 14, 15, 16, 18, 19, 20, 22, 24, 25, 28, 30, 32, 35, 38, 40, 42, 45, 48, 50, 55 and 60 mm.

\*\*Available bore diameters d<sub>3</sub>: 15, 16, 19, 20, 24, 25, 28, 30, 32, 35, 38, 40, 42, 45, 48, 50 and 55 mm.

### Example for Ordering

please indicate when ordering:	type	art. no.	preset limit torque	bore d	bore d <sub>3</sub>	with proximity switch
	SUE 30.1	4479.625. 101	10 Nm	12 mm	20 mm	see pages 60 and 61

torque type  end no.



# Synchronous Ratcheting SIKUMAT - Backlash free with balls

## Series SUL - with torsionally rigid shaft coupling

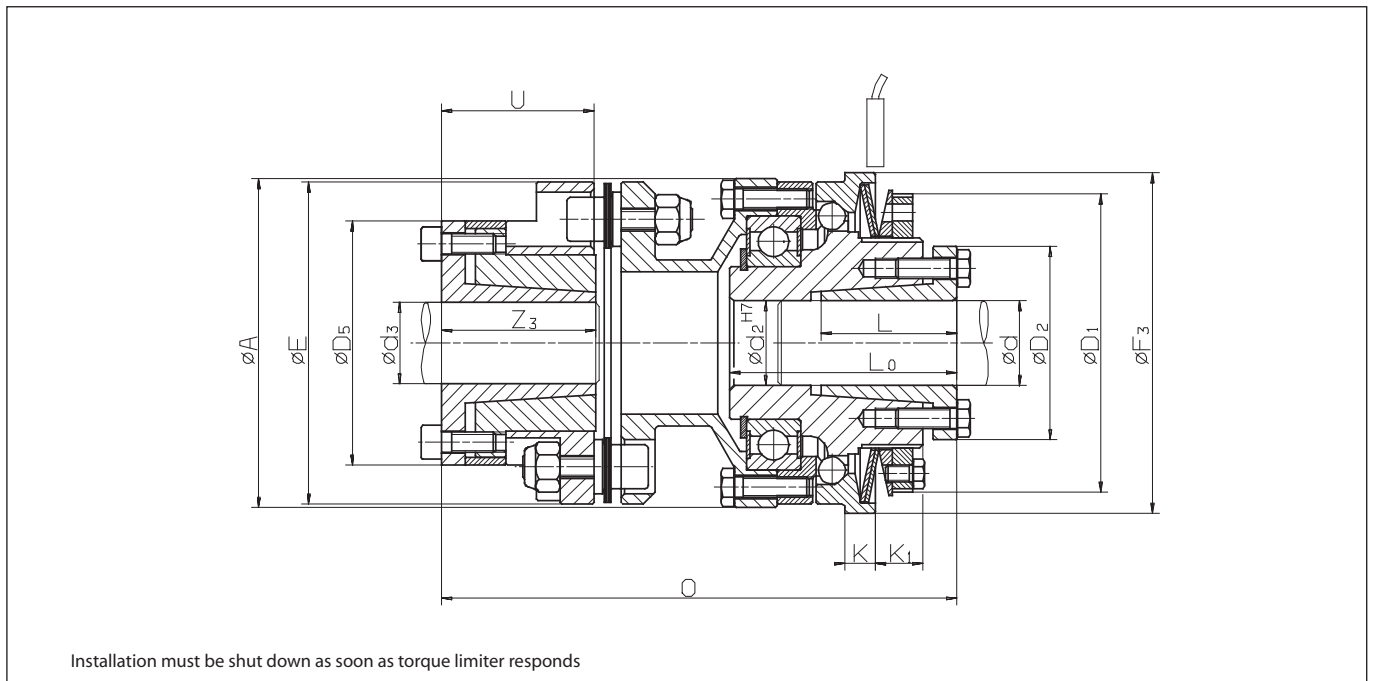

### Technical Data

type	art. no.	torque type 1			torque type 2			torque type 3		
		limit torque Nm	max. speed min <sup>-1</sup>	end no.	limit torque Nm	max. speed min <sup>-1</sup>	end no.	limit torque Nm	max. speed min <sup>-1</sup>	end no.
SUL 30.x	4479.425.xxx	5 - 14	4000	101	10 - 28	4000	102	20 - 60	4000	103
SUL 40.x	4479.430.xxx	9 - 27	3000	101	18 - 54	3000	102	38 - 115	3000	103
SUL 45.x	4479.440.xxx	19 - 60	2500	101	38 - 125	2500	102	70 - 255	2500	103
SUL 55.x	4479.450.xxx	35 - 110	2000	101	80 - 220	2000	102	160 - 440	2000	103
SUL 65.x	4479.460.xxx	80 - 185	1200	101	160 - 370	1200	102	320 - 740	1200	103

### Dimensions

Type	Référence	bore d*		bore d <sub>3</sub> **		A	D <sub>1</sub>	D <sub>2</sub>	D <sub>5</sub>	E	F <sub>3</sub>	K	K <sub>1</sub>	L	L <sub>0</sub>	O	U	Z <sub>3</sub>	Course active
		min. mm	max. mm	mm	mm														
SUL 30.x	4479.425.xxx	10	20	11	20	65	63	40,5	42	53	70	7	12	26	47	95,5	25,5	26,5	1,2
SUL 30.x	4479.425.xxx	19	25	11	20	65	63	42	42	53	70	7	12	26	47	95,5	25,5	26,5	1,2
SUL 40.x	4479.430.xxx	15	30	15	30	80	77	57	58	72	85	8	12	31	56	114,5	33	31	1,5
SUL 45.x	4479.440.xxx	19	40	19	30	97	88	57	58	72	100	9	14	40	67	128	33	31	1,8
SUL 45.x	4479.440.xxx	19	40	24	42	97	88	64	72	89	100	9	14	31	67	150	44,5	45	1,8
SUL 55.x	4479.450.xxx	32	50	24	42	111	100	73,5	72	89	115	10	16	29	73	153,5	44,5	45	2,0
SUL 65.x	4479.460.xxx	32	50	32	42	131	122	73,5	79	118	135	12	21	29	85	163,5	35	29	2,2
SUL 65.x	4479.460.xxx	55	60	45	60	131	122	89	92	118	135	12	21	45,5	86	172,5	44	44	2,2

Hub bore diameter d<sub>2</sub> is equal to the selected diameter d and serves as an additional centering guide.

\*Available bore diameters d: 10, 11, 12, 14, 15, 16, 18, 19, 20, 22, 24, 25, 28, 30, 32, 35, 38, 40, 42, 45, 48, 50, 55 and 60 mm.

\*\*Available bore diameters d<sub>3</sub>: 15, 16, 19, 20, 24, 25, 28, 30, 32, 35, 38, 40, 42, 45, 48, 50 and 55 mm.

### Example for Ordering

please indicate when ordering:	type	art. no.	preset limit torque	bore d	bore d <sub>3</sub>	with proximity switch
		SUL 55.3	4479.450. 103	420 Nm	45 mm	35 mm

torque type  end no.

# Disengaging SIKUMAT with single rollers

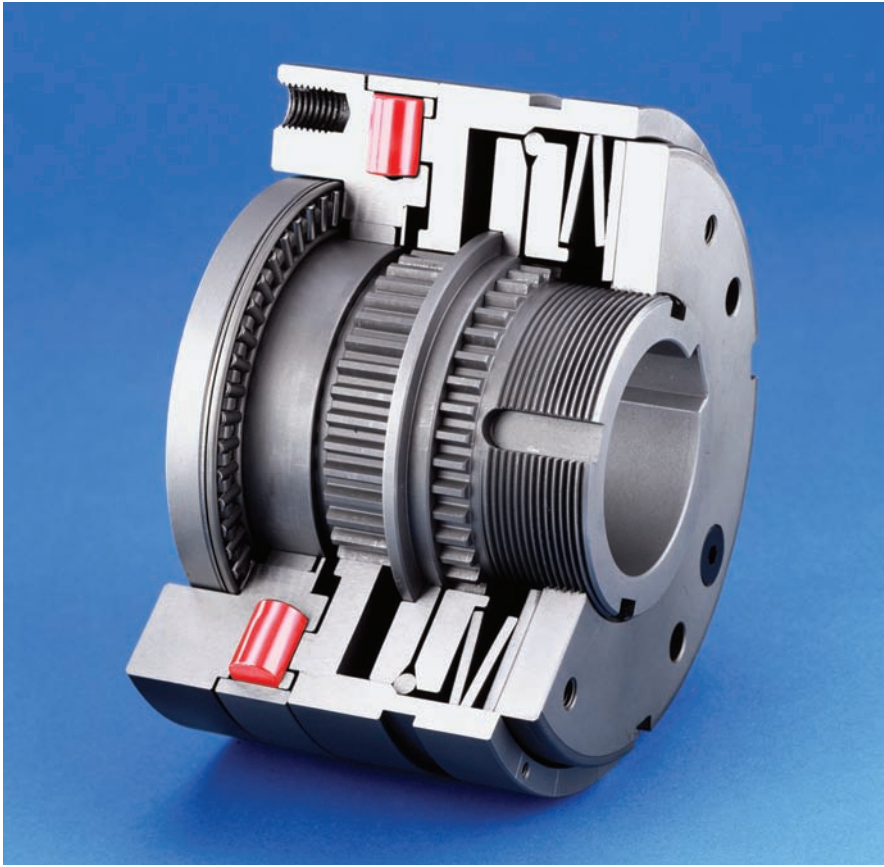

## The Single Roller Principle

The torque is transmitted via rollers which are pressed into detents by Belleville springs. When the preset limit torque has been reached, the detent ring moves axially and the SIKUMAT disengages. A locking mechanism holds the detent ring while it is in disengaged mode.

## Advantages

- Disengages in case of overload – separation of input and output
- Integral fixed bearing
- Keyway in connecting flange for maximum torque capacity
- Calibrated micro adjustment of torque setting possible, even post-installation
- Exchange of current torque limiters possible
- Cost effective

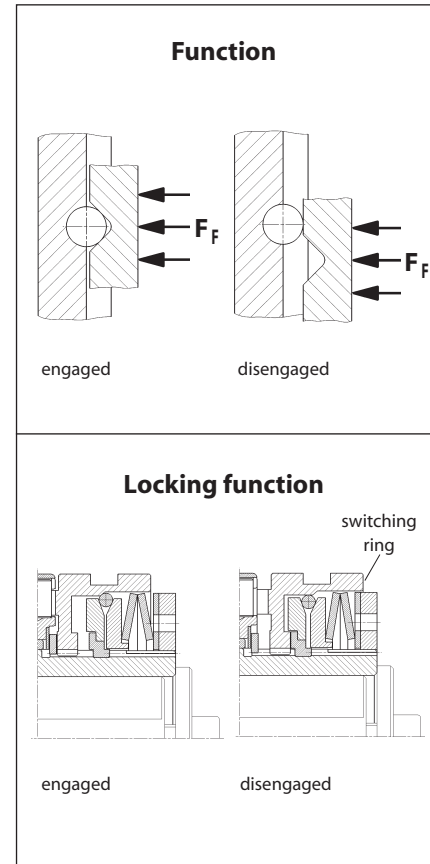

## Function

- When the preset limit torque has been reached the SIKUMAT disengages the input and output.
- After the overload has been eliminated the SIKUMAT can be switched on again manually.
- This means that an axial switching force must be applied to the switching ring.

# Disengaging SIKUMAT with single rollers

## Types

### Series SR - flange design

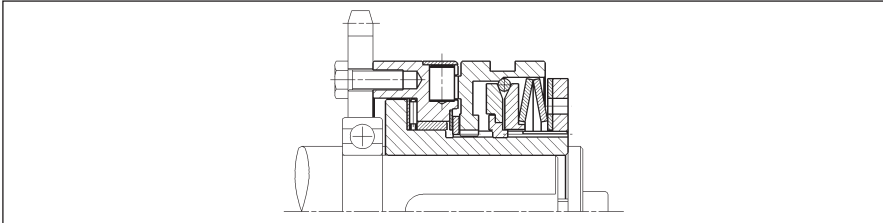

For attaching chain wheels, belt pulleys, gear wheels etc. Bearing of attached component on the shaft to be provided by the customer.

Page 44

### Series SRR - with short hub and integral roller bearing

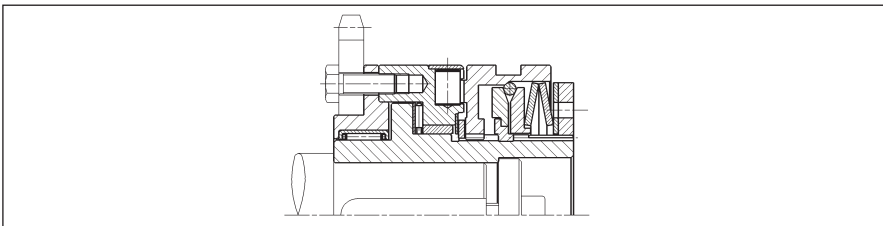

With short hub and needle bearing for narrow connecting parts

Page 45

### Series SRG - with long hub

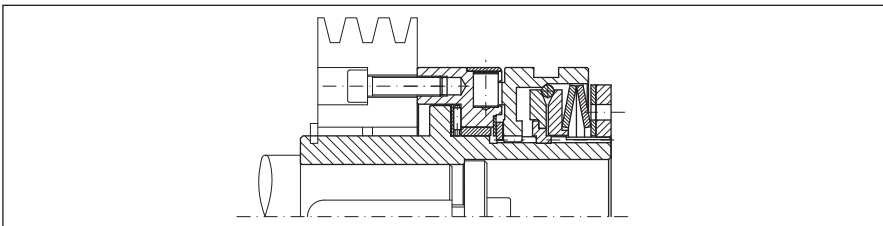

With long hub for wide connecting parts. Plain or needle bearing for the connecting part to be provided by the customer

Page 46

### Series SRE - with flexible shaft coupling

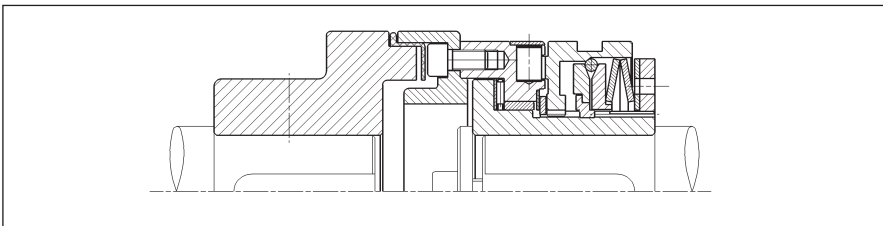

For flexible connection of two shafts. The flexible parts are oil-proof.

Page 47

## Notes

### Torque setting

If requested, the limit torque can be set at the factory. Setting or modification of the limit torque can also be carried out by the customer. See operating instructions for further details.

### Proximity switch

The overload can be indicated by a non-contact or a mechanical proximity switch. Further details on pages 60 and 61.

### Speed Control ESC

The RINGSPANN speed control ESC (Electronic Speed Control) monitors speed deviations and speed differences safely and also under difficult operating conditions. See catalogue 50.1 for details.

# Disengaging SIKUMAT

## with single rollers

### Series SR - flange design

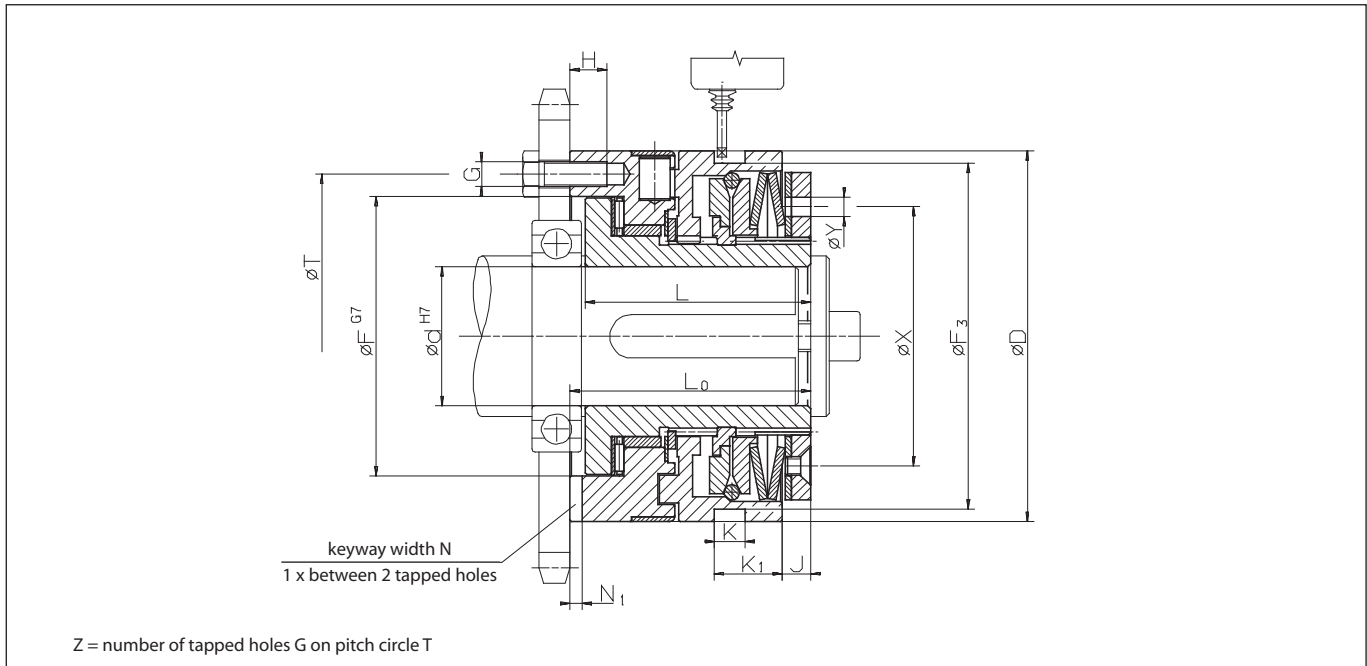

## Technical Data

type	art. no.	torque type 1			torque type 2			torque type 3		
		limit torque Nm	max. speed min <sup>-1</sup>	end no.	limit torque Nm	max. speed min <sup>-1</sup>	end no.	limit torque Nm	max. speed min <sup>-1</sup>	end no.
SR 32.x	4470.020.xxx	5 - 10	6000	601	10 - 20	6000	602	20 - 40	6000	603
SR 40.x	4470.025.xxx	12 - 25	5000	601	25 - 50	5000	602	50 - 100	5000	603
SR 55.x	4470.035.xxx	25 - 50	4000	601	50 - 100	4000	602	100 - 200	4000	603
SR 65.x	4470.045.xxx	50 - 100	3500	601	100 - 200	3500	602	200 - 450	3500	603
SR 80.x	4470.055.xxx	100 - 200	3000	601	200 - 400	3000	602	400 - 800	3000	603
SR 90.x	4470.065.xxx	170 - 450	2300	601	350 - 900	2300	602	600 - 1800	2300	603

## Dimensions

Type	Référence	bore d		D	F	F <sub>3</sub>	G	H	J	K	K <sub>1</sub>	L	L <sub>0</sub>	N	N <sub>1</sub>	T	X	Y	Z	Course active
		min. mm	max. mm																	
SR 32.x*	4470.020.xxx	7	20	55	41	50	M5	6,5	3	9	13,5	35	38,5	6	3,1	48	38,5	5	6	1,2
SR 40.x	4470.025.xxx	10	25	82	60	72,5	M5	8	6	9	14,5	48	52	6	3,1	70	54	6	6	1,8
SR 55.x	4470.035.xxx	14	35	100	78	90,5	M6	10	6	9	15	56	61	8	3,6	89	70	6	6	2,0
SR 65.x	4470.045.xxx	18	45	120	90,5	112	M8	12	8,5	10	22,5	72	78	10	4,1	105	84	6	6	2,2
SR 80.x	4470.055.xxx	24	55	146	105	140	M10	15	11	9	25	93,5	100	12	4,1	125	108	7	6	2,5
SR 90.x	4470.065.xxx	30	70 <sup>1)</sup>	176	120,5	170	M12	17	12	9	30	107	113,5	14	4,6	155	129	10	6	3,0

Keyway as per DIN 6885, page 1 · Tolerance of keyway width JS9

<sup>1)</sup>Keyway as per DIN 6885, page 3 · Tolerance of keyway width JS9

\* SR 32.x available on request

## Example for Ordering

please indicate when ordering:	type	art. no.	preset limit torque	bore d	with proximity switch
	SR 40. 2	4470.025. 602	30 Nm	21 mm	see p.60 and 61

torque type  end no.

# Disengaging SIKUMAT

## with single rollers

### Series SRR - with short hub and integral needle bearing

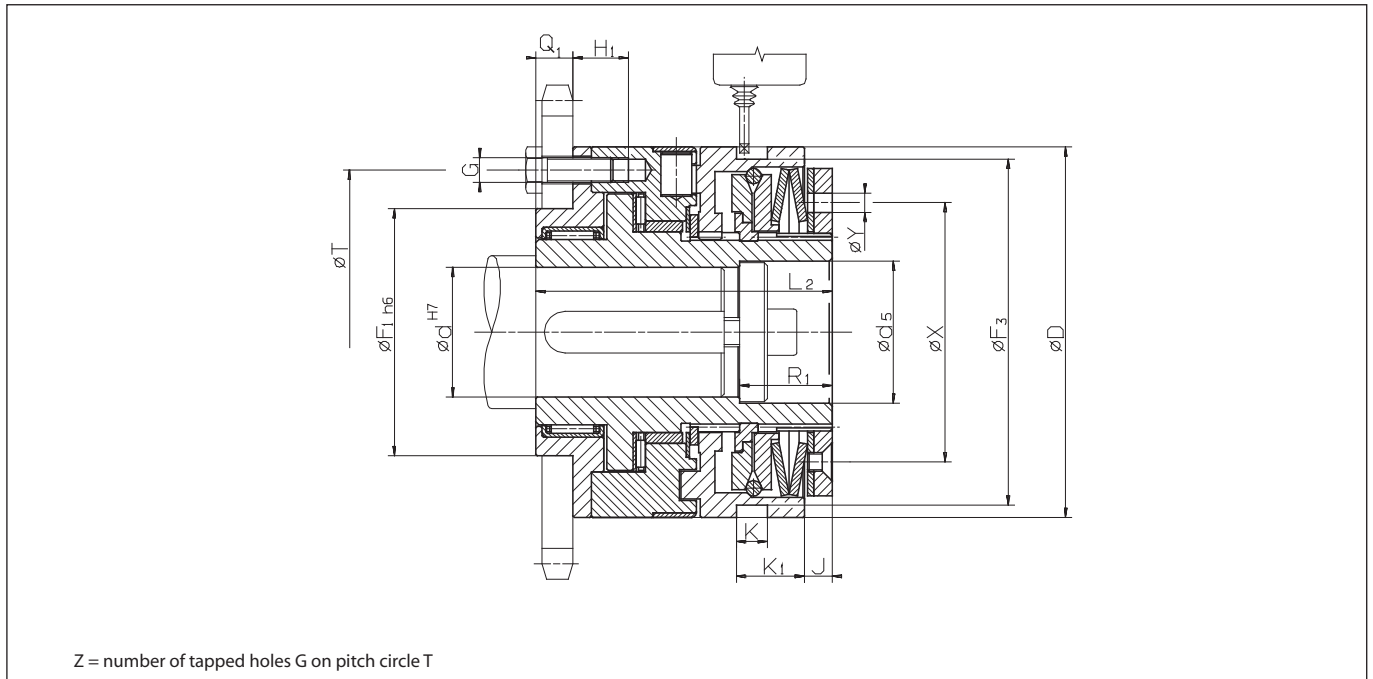

#### Technical Data

type	art. no.	torque type 1			torque type 2			torque type 3		
		limit torque Nm	max. speed min <sup>-1</sup>	end no.	limit torque Nm	max. speed min <sup>-1</sup>	end no.	limit torque Nm	max. speed min <sup>-1</sup>	end no.
SRR 32.x	4470.920.xxx	5 - 10	6000	601	10 - 20	6000	602	20 - 40	6000	603
SRR 40.x	4470.925.xxx	12 - 25	5000	601	25 - 50	5000	602	50 - 100	5000	603
SRR 55.x	4470.935.xxx	25 - 50	4000	601	50 - 100	4000	602	100 - 200	4000	603
SRR 65.x	4470.945.xxx	50 - 100	3500	601	100 - 200	3500	602	200 - 450	3500	603
SRR 80.x	4470.955.xxx	100 - 200	3000	601	200 - 400	3000	602	400 - 800	3000	603
SRR 90.x	4470.965.xxx	170 - 450	2300	601	350 - 900	2300	602	600 - 1800	2300	603

#### Dimensions

Type	Référence	bore d		d <sub>5</sub>	D	F <sub>1</sub>	F <sub>3</sub>	G	H <sub>1</sub>	J	K	K <sub>1</sub>	L <sub>2</sub>	Q <sub>1</sub>	R <sub>1</sub>	T	X	Y	Z	Course active
		min. mm	max. mm																	
SRR 32.x*	4470.920.xxx	7	20	21	55	38	50	M5	11,5	3	9	13,5	51,5	8	15	48	38,5	5	6	1,2
SRR 40.x	4470.925.xxx	10	25	26	82	50	72,5	M5	16	6	9	14,5	70	10	20	70	54	6	6	1,8
SRR 55.x	4470.935.xxx	14	35	36	100	60	90,5	M6	15	6	9	15	78	12	25	89	70	6	6	2
SRR 65.x	4470.945.xxx	18	45	46	120	80	112	M8	18	8,5	10	22,5	96	12	30	105	84	6	6	2,2
SRR 80.x	4470.955.xxx	24	55	56	146	100	140	M10	23,5	11	9	25	124,5	16	30	125	108	7	6	2,5
SRR 90.x	4470.965.xxx	30	70 <sup>1)</sup>	66	176	120	170	M12	25,5	12	9	30	140	18	30	155	129	10	6	3

Keyway as per DIN 6885, page 1 · Tolerance of keyway width JS9

<sup>1)</sup>Keyway as per DIN 6885, page 3 · Tolerance of keyway width JS9

\* SRR 32.x available on request

#### Example for Ordering

please indicate when ordering:	type	art. no.	preset limit torque	bore d	with proximity switch
	SRR 40. 2	4470.925. 602	31 Nm	21 mm	see p. 60 and 61

torque type  end no.

# Disengaging SIKUMAT

## with single rollers

### Series SRG - with long hub

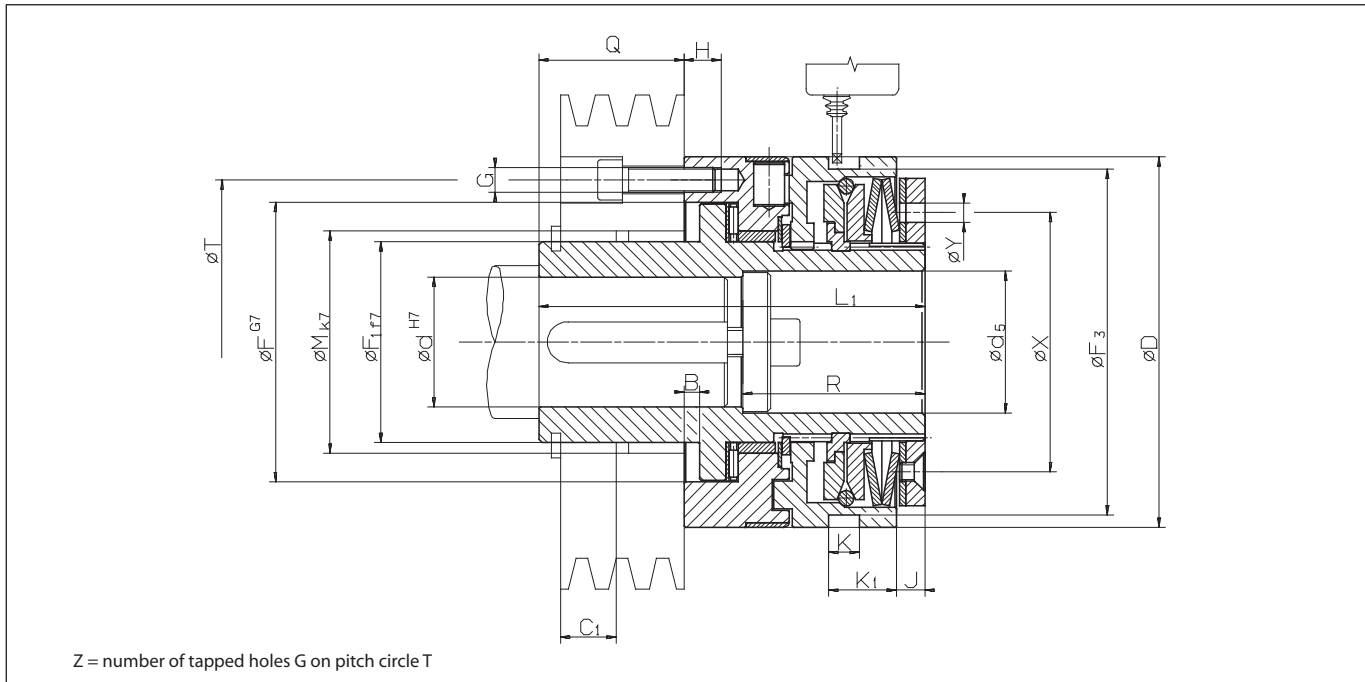

### Technical Data

type	art. no.	torque type 1			torque type 2			torque type 3		
		limit torque Nm	max. speed min <sup>-1</sup>	end no.	limit torque Nm	max. speed min <sup>-1</sup>	end no.	limit torque Nm	max. speed min <sup>-1</sup>	end no.
SRG 32.x	4470.120.xxx	5 - 10	6000	601	10 - 20	6000	602	20 - 40	6000	603
SRG 40.x	4470.125.xxx	12 - 25	5000	601	25 - 50	5000	602	50 - 100	5000	603
SRG 55.x	4470.135.xxx	25 - 50	4000	601	50 - 100	4000	602	100 - 200	4000	603
SRG 65.x	4470.145.xxx	50 - 100	3500	601	100 - 200	3500	602	200 - 450	3500	603
SRG 80.x	4470.155.xxx	100 - 200	3000	601	200 - 400	3000	602	400 - 800	3000	603
SRG 90.x	4470.165.xxx	170 - 450	2300	601	350 - 900	2300	602	600 - 1800	2300	603

### Dimensions

Type	Référence	bore d		d <sub>5</sub>	B	D	F	F <sub>1</sub>	F <sub>3</sub>	G	H	J	K	K <sub>1</sub>	L <sub>1</sub>	Q	R	T	X	Y	Z	Course active
		min. mm	max. mm																			
SRG 32.x*	4470.120.xxx	7	20	21	4	55	41	28	50	M5	6,5	3	9	13,5	66	27,5	25,5	48	38,5	5	6	1,2
SRG 40.x	4470.125.xxx	10	25	26	4	82	60	38	72,5	M5	8	6	9	14,5	83	33	35	70	54	6	6	1,8
SRG 55.x	4470.135.xxx	14	35	36	5	100	78	52	90,5	M6	10	6	9	15	100	39	45	89	70	6	6	2,0
SRG 65.x	4470.145.xxx	18	45	46	5	120	90,5	65	112	M8	12	8,5	10	22,5	125	47	59	105	84	6	6	2,2
SRG 80.x	4470.155.xxx	24	55	56	6,5	146	105	78	140	M10	15	11	9	25	152,5	52,5	60	125	108	7	6	2,5
SRG 90.x	4470.165.xxx	30	70 <sup>1)</sup>	66	6,5	176	120,5	90	170	M12	17	12	9	30	171	57,5	60	155	129	10	6	3,0

Keyway as per DIN 6885, page 1 · Tolerance of keyway width JS9

<sup>1)</sup> Keyway as per DIN 6885, page 1 · Tolerance of keyway width JS9

\* SRG 32.x available on request

### Example for Ordering

please indicate when ordering:	type	art. no.	preset limit torque	bore d	with proximity switch
	SRG 40. 2	4470.125. 602	30 Nm	21 mm	see p.60 and 61

torque type  end no.

# Disengaging SIKUMAT

## with single rollers

### Series SRE - with flexible shaft coupling

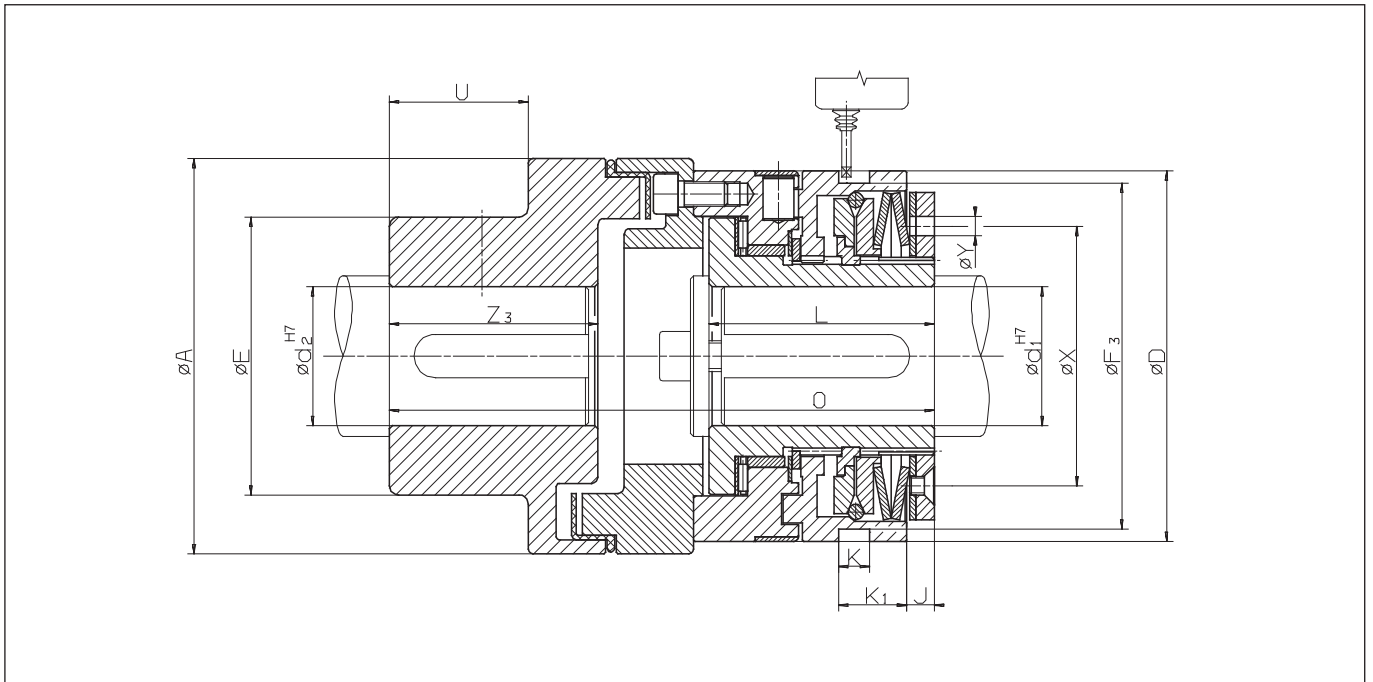

#### Technical Data

type	art. no.	torque type 1			torque type 2			torque type 3		
		limit torque Nm	max. speed min <sup>-1</sup>	end no.	limit torque Nm	max. speed min <sup>-1</sup>	end no.	limit torque Nm	max. speed min <sup>-1</sup>	end no.
SRE 32.x	4470.620.xxx	5 - 10	6000	601	10 - 20	6000	602	20 - 40	6000	603
SRE 40.x	4470.625.xxx	12 - 25	5000	601	25 - 50	5000	602	50 - 100	5000	603
SRE 55.x	4470.635.xxx	25 - 50	4000	601	50 - 100	4000	602	100 - 200	4000	603
SRE 65.x	4470.645.xxx	50 - 100	3500	601	100 - 200	3500	602	200 - 450	3500	603
SRE 80.x	4470.655.xxx	100 - 200	3000	601	200 - 400	3000	602	400 - 800	3000	603
SRE 90.x	4470.665.xxx	170 - 450	2300	601	350 - 900	2300	602	600 - 1800	2300	603

#### Dimensions

Type	Référence	bore		d <sub>2</sub> max. mm	A mm	E mm	D mm	F <sub>3</sub> mm	J mm	K mm	K <sub>1</sub> mm	L mm	O mm	U mm	X mm	Y mm	Z <sub>3</sub> mm	Course active mm
		d <sub>1</sub> min. mm	d <sub>1</sub> max. mm															
SRE 32.x*	4470.620.xxx	7	20	30	67	46	55	50	3	9	13,5	35	86	15	38,5	5	28	1,6
SRE 40.x	4470.625.xxx	10	25	50	112	79	82	72,5	6	9	14,5	48	137,5	38	54	6	58	2,3
SRE 55.x	4470.635.xxx	14	35	50	112	79	100	90,5	6	9	15	56	147	38	70	6	58	3,0
SRE 65.x	4470.645.xxx	18	45	60	128	90	120	112	8,5	10	22,5	72	176,5	45	84	6	67	3,5
SRE 80.x	4470.655.xxx	24	55	60	148	90	146	140	11	9	25	93,5	211,5	45	108	7	67	3,8
SRE 90.x	4470.665.xxx	30	70 <sup>1)</sup>	70	177	107	176	170	12	9	30	107	242,5	52	129	10	75	4,5
SRE 90.3	4470.665.xxx	30	70 <sup>1)</sup>	90	198	140	176	170	12	9	30	107	272	52	129	10	75	4,5

Keyway as per DIN 6885, page 1 · Tolerance of keyway width JS9

<sup>1)</sup> Keyway as per DIN 6885, page 1 · Tolerance of keyway width JS9

\* SRE 32.x available on request

#### Example for Ordering

please indicate when ordering:	type	art. no.	preset limit torque	bore d <sub>1</sub>	bore d <sub>2</sub>	with proximity switch
		SRE 40. 2	4470.625. 602	35 Nm	21 mm	35 mm

torque type  end no.

# Synchronous Disengaging SIKUMAT with double rollers

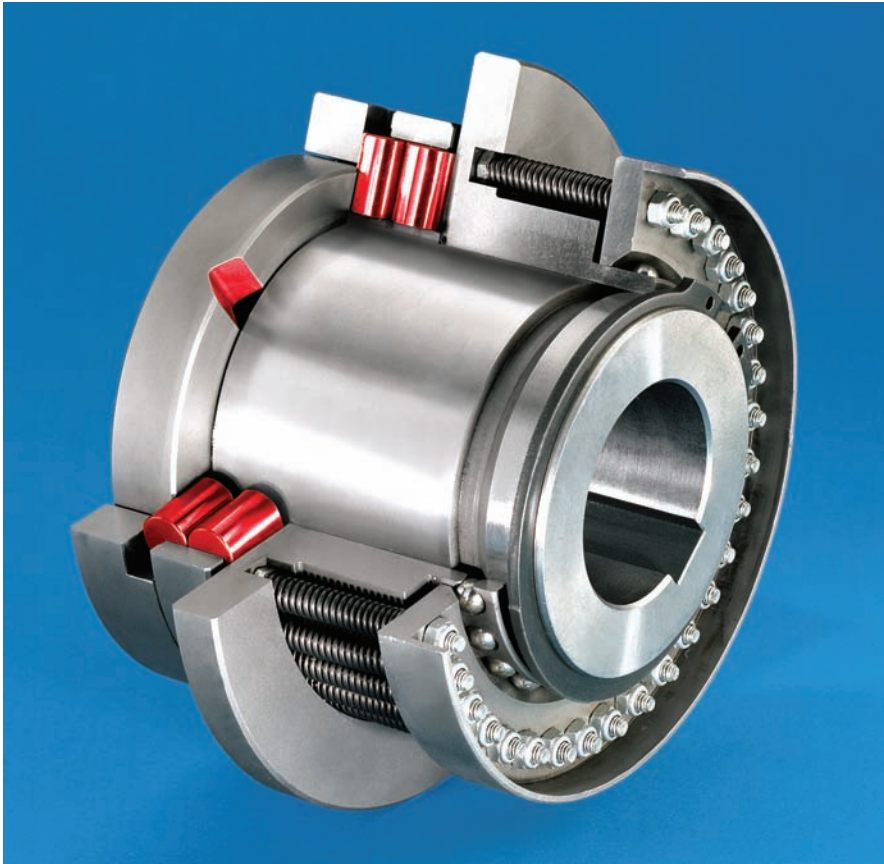

## The Double Roller Principle

The torque is transmitted via six pairs of rollers which are pressed by coil springs into detents. When the preset limit torque has been reached, the rollers move against the spring force up the sloping surface and disengage. This characteristic combined with the particular geometry of the detents provide a high degree of consistency to the limit torque of the SIKUMAT over the duration of the operating period. Re-engagement is effected synchronously after 360° due to the asymmetrical division of the detents.

## Advantages

- High degree of consistency of limit torque over the duration of operation through double roller principle
- Switching off in case of overload – separation of input and output
- Synchronous re-engagement after 360°
- Torques up to 10 000 Nm
- For shaft diameters up to 125 mm
- Protection against unauthorised adjustment of the limit torque

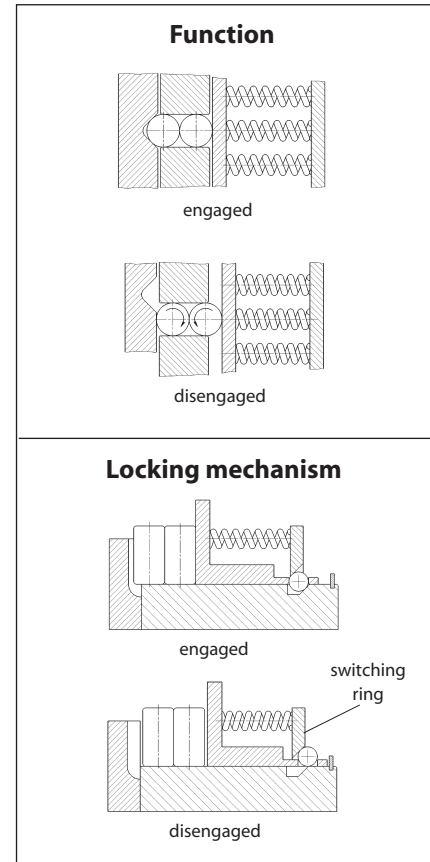

## Function

- When the preset limit torque has been reached the SIKUMAT effects a separation of input and output by means of a locking mechanism with integral bearings.
- Following elimination of the overload manual synchronous re-engagement of the SIKUMAT to the starting position after 360°.
- This requires an axial switching force to be applied to the switching ring.



# Synchronous Disengaging SIKUMAT with double rollers

## Types

### Series SB - flange design

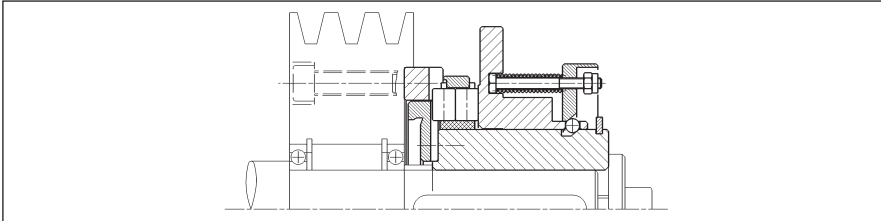

For attaching chain wheels, belt pulleys, gear wheels etc. Bearing of attached component on the shaft to be provided by the customer.

Page 50

### Series SBG - with long hub

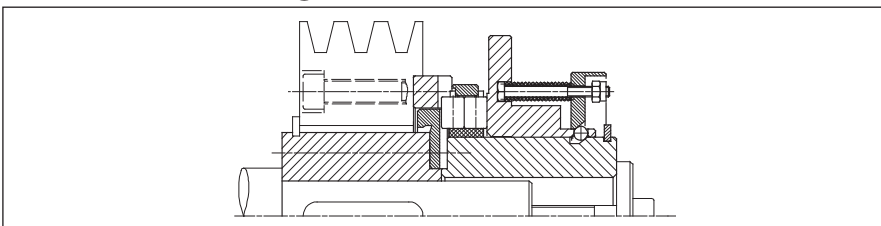

With long hub for wide connecting parts. Delivery includes plain bearing

Page 51

### Series SBE - with flexible shaft coupling

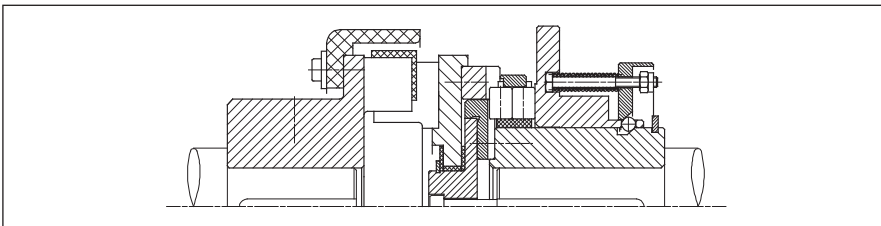

For flexible connection of two shafts. The flexible parts are oil-proof.

Page 52

### Series SBL - with torsionally rigid shaft coupling

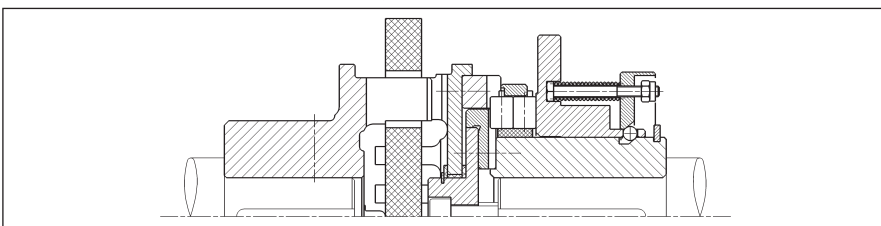

For torsionally rigid connection of two shafts. Can accommodate large radial and angular displacements.

Page 53

## Notes

### Torque setting

The limit torque is normally set at the factory. Setting or modification of the limit torque can also be carried out by the customer but no unauthorised adjustment can be carried out by the machine operator. See operating instructions for further details.

### Proximity switch

The overload can be indicated by a non-contact or a mechanical proximity switch. Further details on pages 60 and 61.

### Speed Control ESC

The RINGSPANN speed control ESC (Electronic Speed Control) monitors speed deviations and speed differences safely and also under difficult operating conditions. See catalogue 50.1 for details.

# Synchronous Disengaging SIKUMAT with double rollers

## Series SB - flange design

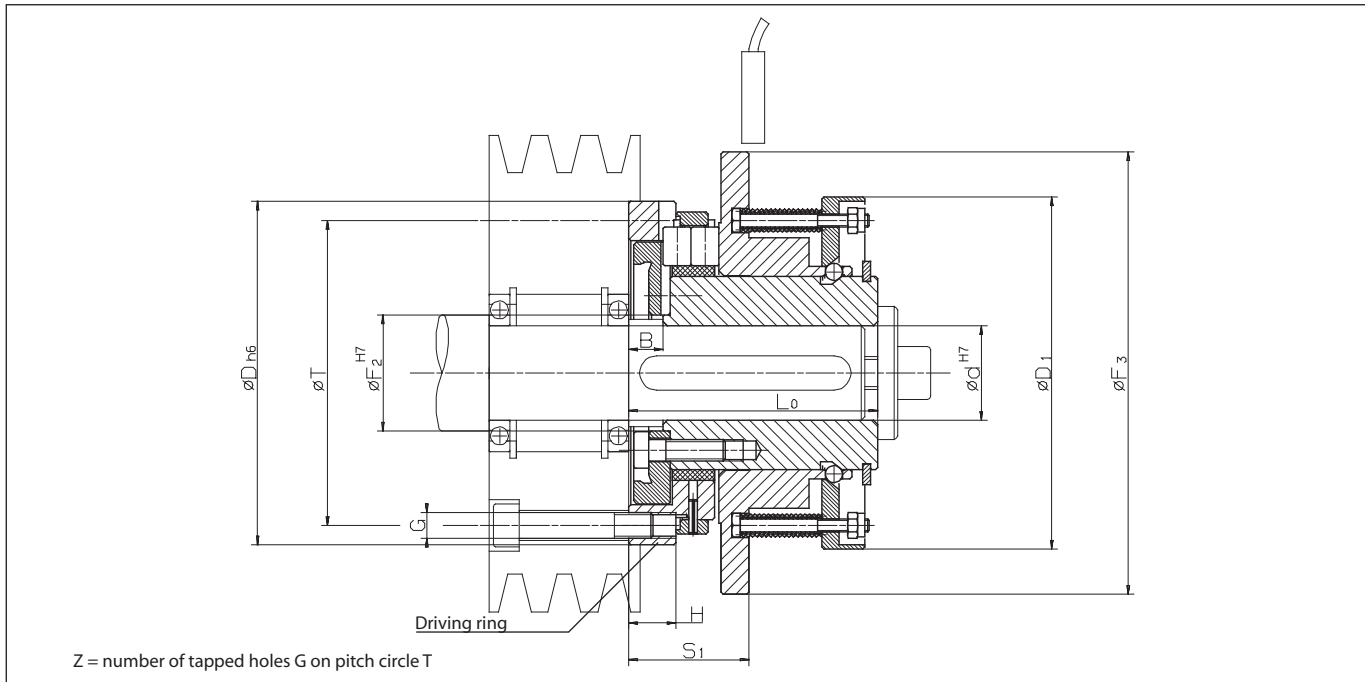

### Technical Data

type	art. no.	limit torque	max. speed
		Nm	min <sup>-1</sup>
SB 4	4470.004.900	8 - 80	6000
SB 7	4470.007.900	26 - 310	3800
SB 11	4470.011.900	105 - 1250	2500
SB 14	4470.014.900	210 - 2500	2100
SB 18	4470.018.900	420 - 5000	1700
SB 22	4470.022.900	840 - 10000	1300

### Dimensions

Type	Référence	bore d		B	D	D <sub>1</sub>	F <sub>2</sub>	F <sub>3</sub>	G	H	L <sub>0</sub>	S <sub>1</sub>	T	Z	Course active
		min. mm	max. mm												
SB 4	4470.004.900	9	25	8	80	82	27	103	M6	11	58	28	71	3	1,6
SB 7	4470.007.900	25	40	10	125	125	43	150	M8	19	90	43	109	3	2,5
SB 11	4470.011.900	30	65	15	180	185	75	224	M10	16	140	69	160	6	4,0
SB 14	4470.014.900	50	80	20	224	224	95	272	M12	18	180	87	200	6	5,0
SB 18	4470.018.900	65	100	24	280	280	118	335	M16	25	224	110	250	6	6,2
SB 22	4470.022.900	80	125	30	355	355	150	412	M20	30	280	140	315	6	8,0

Keyway as per DIN 6885, page 1 · Tolerance of keyway width P9

### Example for Ordering

please indicate when ordering:	type	art. no.	preset limit torque	bore d	with proximity switch
		SB 4	4470.004.900	15 Nm	20 mm

# Synchronous Disengaging SIKUMAT

## with double rollers

### Series SBG - with long hub

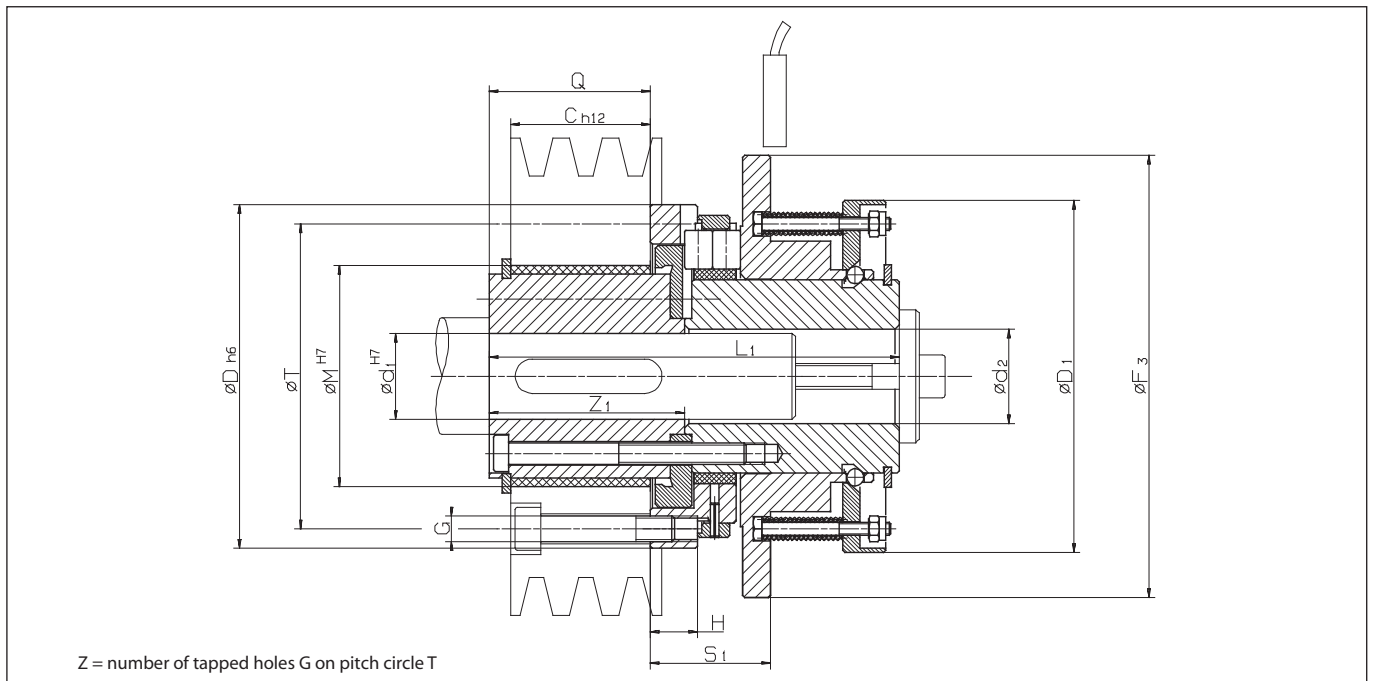

#### Technical Data

type	art. no.	limit torque		max. speed
		Nm		
SBG 4	4470.104.900	8 -	80	6000
SBG 7	4470.107.900	26 -	310	3800
SBG 11	4470.111.900	105 -	1250	2500
SBG 14	4470.114.900	210 -	2500	2100

#### Dimensions

Type	Référence	bore d <sub>1</sub>		C	D	D <sub>1</sub>	F <sub>3</sub>	G	H	L <sub>1</sub>	M	Q	S <sub>1</sub>	T	Z	Z <sub>1</sub>	Course active
		min. mm	max. mm														
SBG 4	4470.104.900	9	25	25	80	82	103	M6	11	103	55	32	24	71	3	39	1,6
SBG 7	4470.107.900	25	40	40	125	125	150	M8	19	155	80	46	38	109	3	55	2,5
SBG 11	4470.111.900	40	65	63	180	185	224	M10	16	250	120	75	61	160	6	87	4,0
SBG 14	4470.114.900	50	80	80	224	224	272	M12	18	275	155	95	87	200	6	109	5,0

Bore d<sub>2</sub> is 0,2...0,5 mm larger than d<sub>1</sub> for sizes 4 – 7

Bore d<sub>2</sub> is 0,5...1,0 mm larger than d<sub>1</sub> for sizes 11 – 14

Keyway as per DIN 6885, page 1 · Tolerance of keyway width P9

#### Example for Ordering

please indicate when ordering:	type	art. no.	preset limit torque	bore d <sub>1</sub>	with proximity switch
		SBG 4	4470.104.900	15 Nm	18 mm

# Synchronous Disengaging SIKUMAT with double rollers

## Series SBE - with flexible shaft coupling

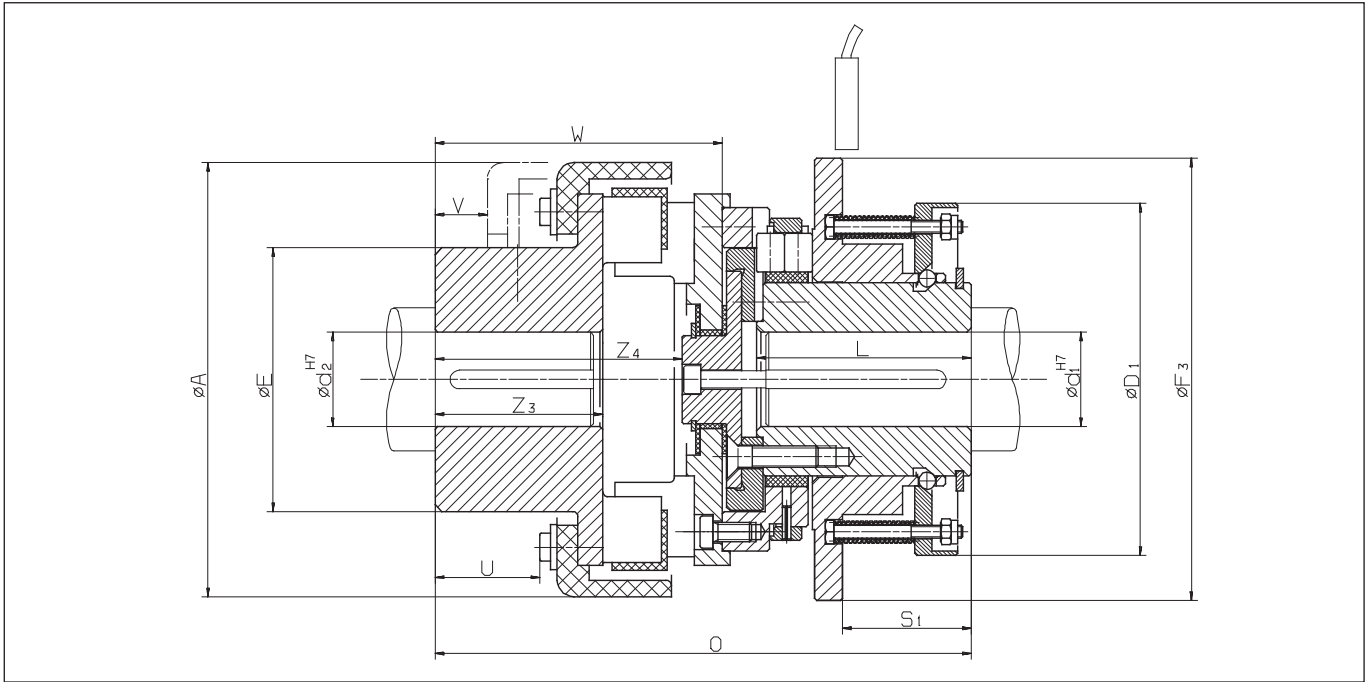

### Technical Data

type	art. no.	limit torque	max. speed
		Nm	min <sup>-1</sup>
SBE 4	4470.604.900	8 - 80	6000
SBE 7	4470.607.900	26 - 310	3800
SBE 11	4470.611.900	105 - 1250	2500
SBE 14	4470.614.900	210 - 2500	2100
SBE 18	4470.618.900	420 - 5000	1700
SBE 22	4470.622.900	840 - 10000	1300

### Dimensions

Type	Référence	bore d <sub>1</sub>		bore d <sub>2</sub>		A	D <sub>1</sub>	F <sub>3</sub>	E	L	O	S <sub>1</sub>	U	V	W	Z <sub>3</sub>	Z <sub>4</sub>	Course active
		min. mm	max. mm	min. mm	max. mm													
SBE 4	4470.604.900	9	25	5	45	114	82	103	72	50	133	30	28	19	75	41	63	1,6
SBE 7	4470.607.900	25	40	20	60	158	125	150	96	80	202	47	39	21	112	61	97	2,5
SBE 11	4470.611.900	30	65	25	80	230	185	224	130	125	283	71	49	21	143	82	124	4
SBE 14	4470.614.900	50	80	45	100	294	224	272	160	160	359	93	56	17	179	97	153	5
SBE 18	4470.618.900	65	100	60	120	330	280	335	195	200	430	114	80	25	206	116	179	6,2
SBE 22	4470.622.900	80	125	75	160	432	355	412	255	250	563	140	104	31	283	160	247	8

Keyway as per DIN 6885, page 1 - Tolerance of keyway width P9

### Example for Ordering

please indicate when ordering:	type	art. no.	preset limit torque	bore d <sub>1</sub>	bore d <sub>2</sub>	with proximity switch
		SBE 4	4470.604.900	15 Nm	14 mm	30 mm

# Synchronous Disengaging SIKUMAT with double rollers

## Series SBL - with torsionally rigid shaft coupling

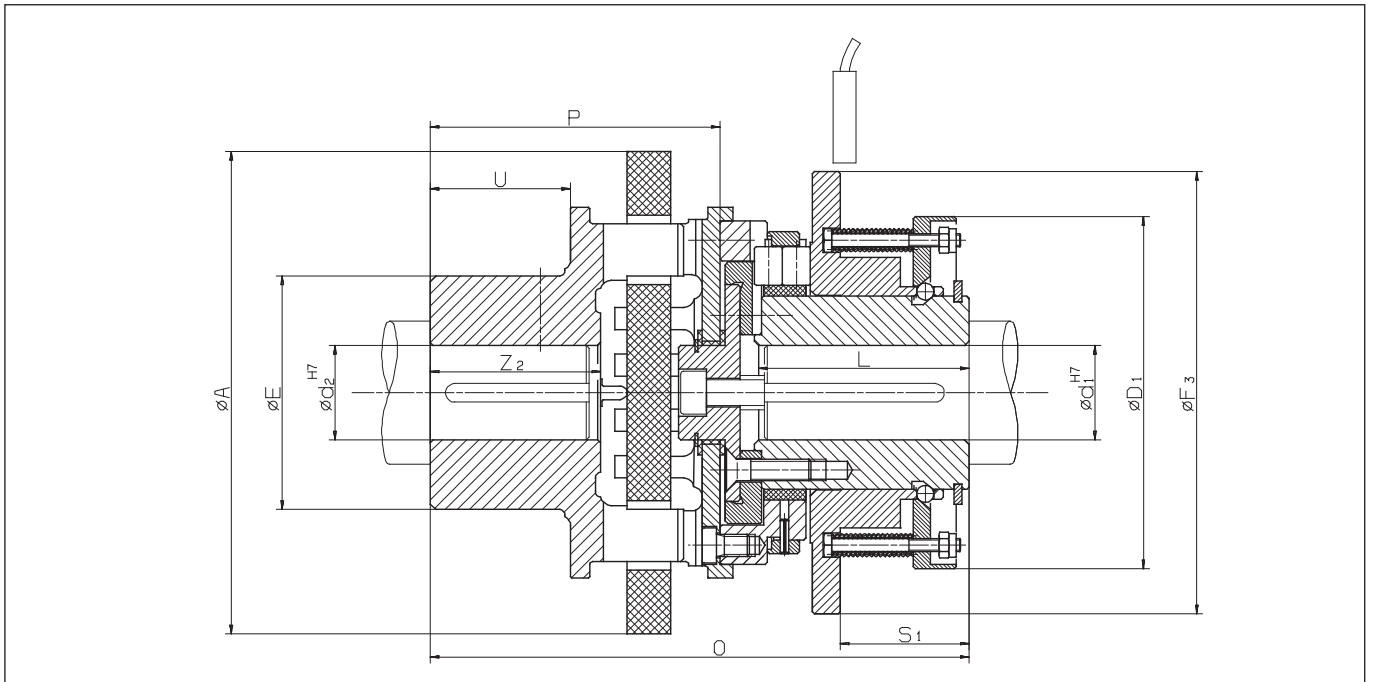

### Technical Data

type	art. no.	limit torque		max. speed
		Nm		min <sup>-1</sup>
SBL 4	4470.404.900	8 -	80	4 100
SBL 7	4470.407.900	26 -	310	2 670
SBL 11	4470.411.900	105 -	1 250	1 700
SBL 14	4470.414.900	210 -	2 500	1 350
SBL 18	4470.418.900	420 -	5 000	1 350
SBL 22	4470.422.900	840 -	10 000	1 050

### Dimensions

Type	Référence	bore d <sub>1</sub>		bore d <sub>2</sub>		A	D <sub>1</sub>	E	F <sub>3</sub>	L	O	P	U	S <sub>1</sub>	Z <sub>2</sub>	Course active
		min. mm	max. mm	min. mm	max. mm											
SBL 4	4470.404.900	9	25	16	35	110	82	53	103	50	135	77	33	30	42	1,6
SBL 7	4470.407.900	25	40	30	50	160	125	85	150	80	195	105	51	47	62	2,5
SBL 11	4470.411.900	30	65	50	90	250	185	150	224	125	300	160	81	71	100	4,0
SBL 14	4470.414.900	50	80	60	110	315	224	175	272	160	384	204	101	93	124	5,0
SBL 18	4470.418.900	65	100	60	110	315	280	175	335	200	462	238	101	114	124	6,2
SBL 22	4470.422.900	80	125	75	140	400	355	216	412	250	600	320	130	140	160	8,0

Permissible radial displacement 0,015 x ØA · Permissible angular displacement max. 3°  
Keyway as per DIN 6885, page 1 · Tolerance of keyway width P9

### Example for Ordering

please indicate when ordering:	type	art. no.	preset limit torque	bore d <sub>1</sub>	bore d <sub>2</sub>	with proximity switch
		SBL 4	4470.404.900	23 Nm	11 mm	21 mm

# Non-disengaging SIKUMAT with single rollers

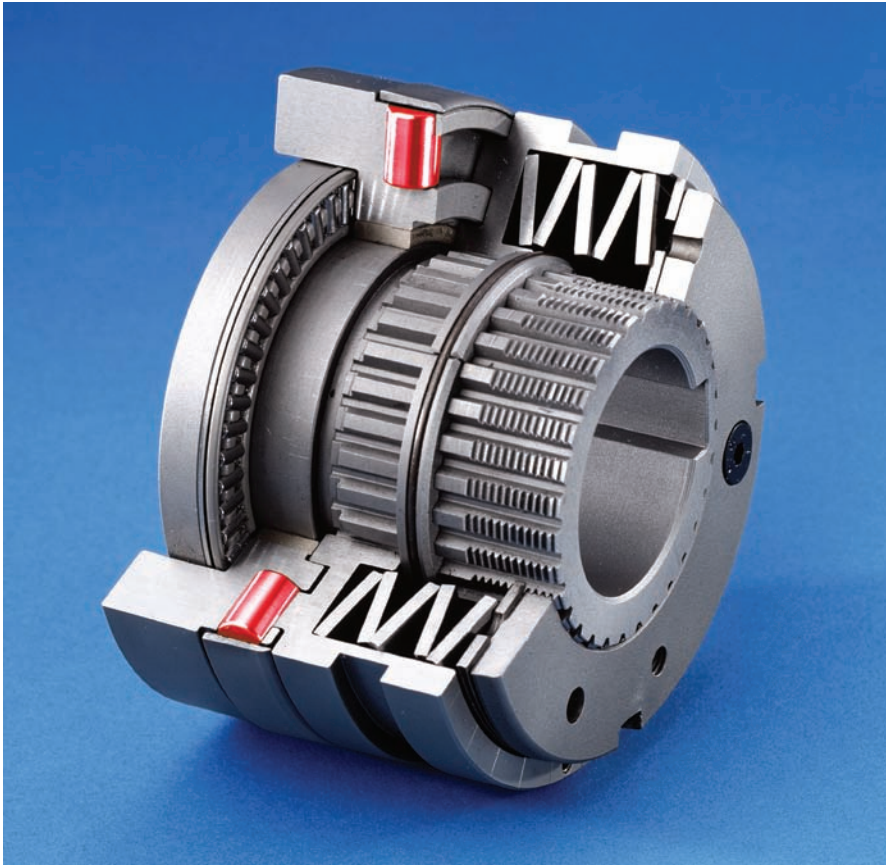

## The Single Roller Principle

The torque is transmitted via rollers which are pressed by Belleville springs into detents. When the preset limit torque has been reached, the detent ring is displaced but is prevented by its particular design from disengaging completely. There is therefore no disengaging of input and output.

## Advantages

- Output is fully driven even in case of overload
- Integral fixed bearing
- Driving keyway in the connecting flange for maximum torque capacity.
- Calibrated micro adjustment of torque setting possible, even post-installation
- Exchange of current torque limiters possible
- Cost effective

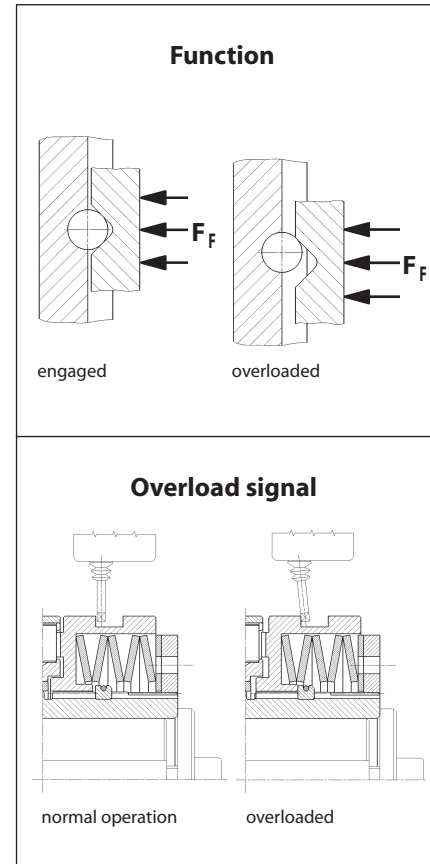

## Function

- When the preset limit torque has been reached, a limit sensor indicates the overload.
- There is no interruption of torque transmission between drive and output.

# Non-disengaging SIKUMAT with single rollers

## Types

### Series SL - flange design

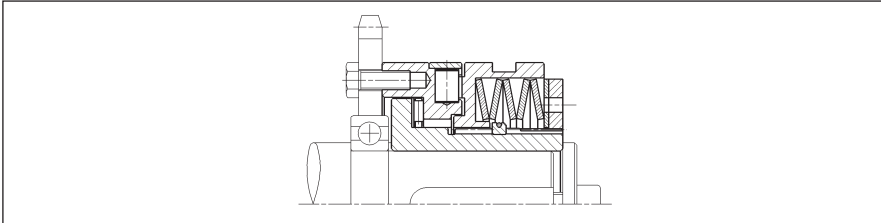

For attaching chain wheels, belt pulleys, gear wheels etc. Bearing of attached component on the shaft to be provided by the customer.

Page 56

### Series SLR - with short hub and integral needle bearing

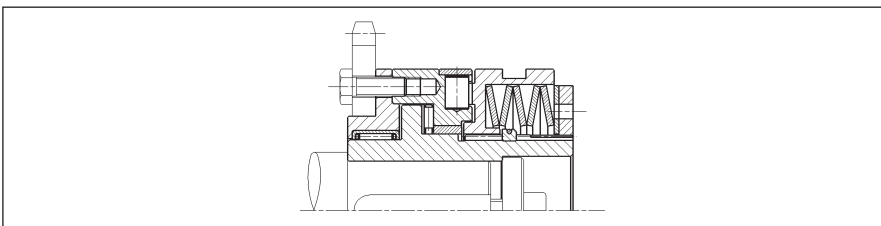

With short hub supported by needle bearings, for connecting narrow components

Page 57

### Series SLG - with long hub

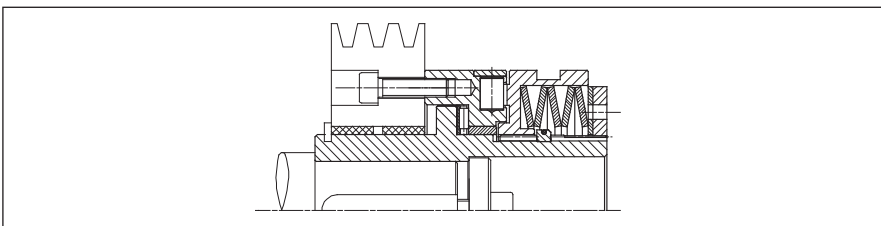

With long hub for connecting wide components. Bearings of the attached component to be provided by the customer

Page 58

### Series SLE - with flexible shaft coupling

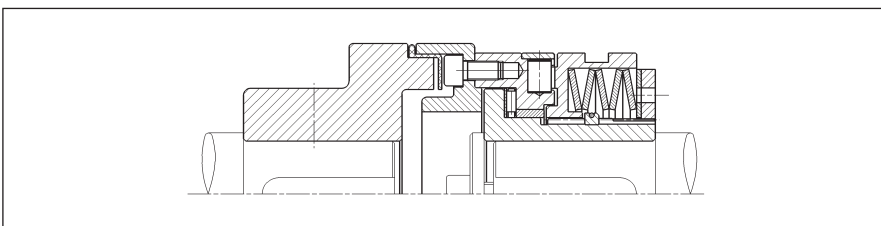

For flexible connection of two shafts. The flexible parts are oil-proof.

Page 59

## Notes

### Torque setting

The limit torque can be set at the factory on request. Setting or modification of the limit torque can also be carried out by the customer. See operating instructions for further details.

### Proximity switch

The overload can be indicated by a non-contact or a mechanical proximity switch. Further details on pages 60 and 61.

### Speed Control ESC

The RINGSPANN speed control ESC (Electronic Speed Control) monitors speed deviations and speed differences safely and also under difficult operating conditions. See catalogue 50.1 for details.

# Non-disengaging SIKUMAT with single rollers

## Series SL - flange design

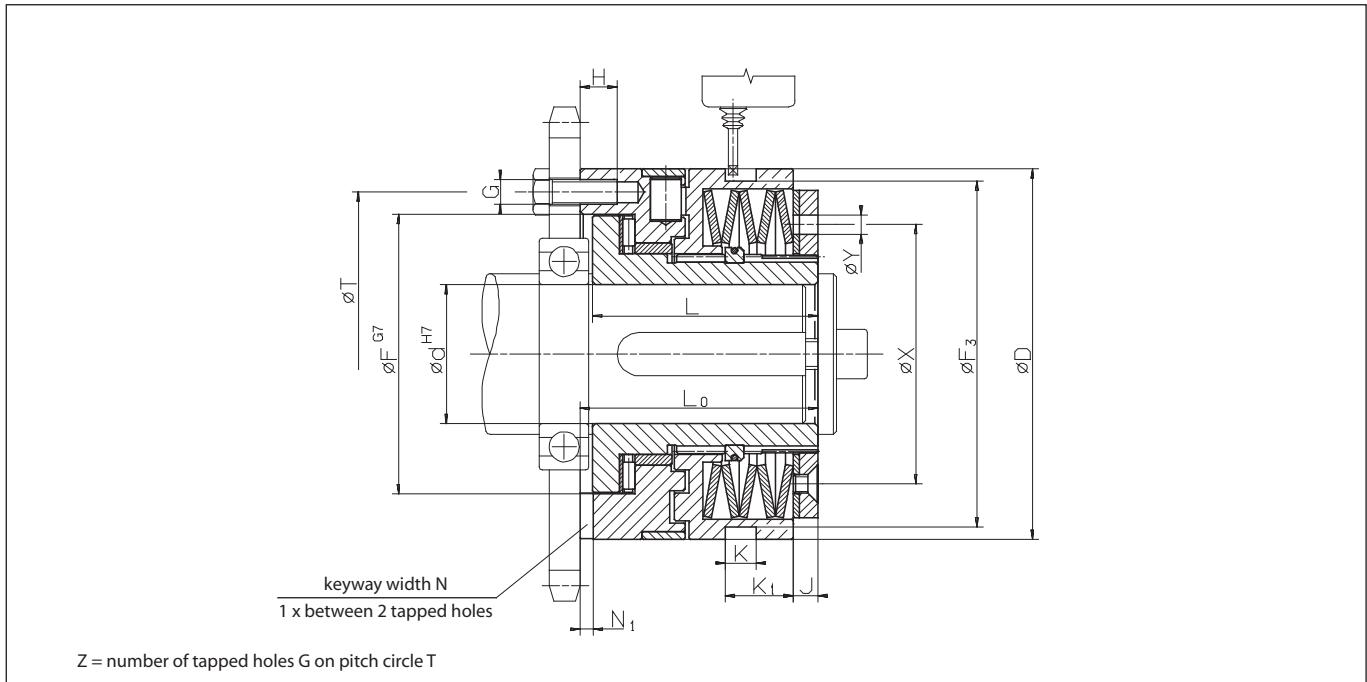

### Technical Data

type	art. no.	torque type 1			torque type 2			torque type 3		
		limit torque Nm	max. speed min <sup>-1</sup>	end no.	limit torque Nm	max. speed min <sup>-1</sup>	end no.	limit torque Nm	max. speed min <sup>-1</sup>	end no.
SL 32.x	4470.020.xxx	5 - 10	4000	701	10 - 20	4000	702	20 - 40	3000	703
SL 40.x	4470.025.xxx	12 - 25	3900	701	25 - 50	3900	702	50 - 100	2900	703
SL 55.x	4470.035.xxx	25 - 50	3300	701	50 - 100	3300	702	100 - 200	2400	703
SL 65.x	4470.045.xxx	50 - 100	2800	701	100 - 200	2800	702	200 - 450	2000	703
SL 80.x	4470.055.xxx	100 - 200	2300	701	200 - 400	2300	702	400 - 800	1600	703
SL 90.x	4470.065.xxx	170 - 450	1800	701	350 - 900	1800	702	600 - 1800	1400	703

### Dimensions

Type	Référence	bore d		D	F	F <sub>3</sub>	G	H	J	K	K <sub>1</sub>	L	L <sub>0</sub>	N	N <sub>1</sub>	T	X	Y	Z	Course active
		min. mm	max. mm																	
SL 32.x	4470.020.xxx	7	20	55	41	50	M5	6,5	3	9	13,5	35	38,5	6	3,1	48	38,5	5	6	0,6
SL 40.x	4470.025.xxx	10	25	82	60	72,5	M5	8	6	9	14,5	48	52	6	3,1	70	54	6	6	0,8
SL 55.x	4470.035.xxx	14	35	100	78	90,5	M6	10	6	9	15	56	61	8	3,6	89	70	6	6	1,1
SL 65.x	4470.045.xxx	18	45	120	90,5	112	M8	12	8,5	10	22,5	72	78	10	4,1	105	84	6	6	1,2
SL 80.x	4470.055.xxx	24	55	146	105	140	M10	15	11	9	25	93,5	100	12	4,1	125	108	7	6	1,2
SL 90.x	4470.065.xxx	30	70 <sup>1)</sup>	176	120,5	170	M12	17	12	9	30	107	113,5	14	4,6	155	129	10	6	1,6

Keyway as per DIN 6885, page 1 · Tolerance of keyway width JS9

<sup>1)</sup>Keyway as per DIN 6885, page 3 · Tolerance of keyway width JS9

### Example for Ordering

please indicate when ordering:	type	art. no.	preset limit torque	bore d	with proximity switch
	SL 32. 1	4470.020. 701	9 Nm	14 mm	see p.60 and 61

torque type  end no.



# Non-disengaging SIKUMAT

## with single rollers

### Series SLR - with short hub and integral needle bearing

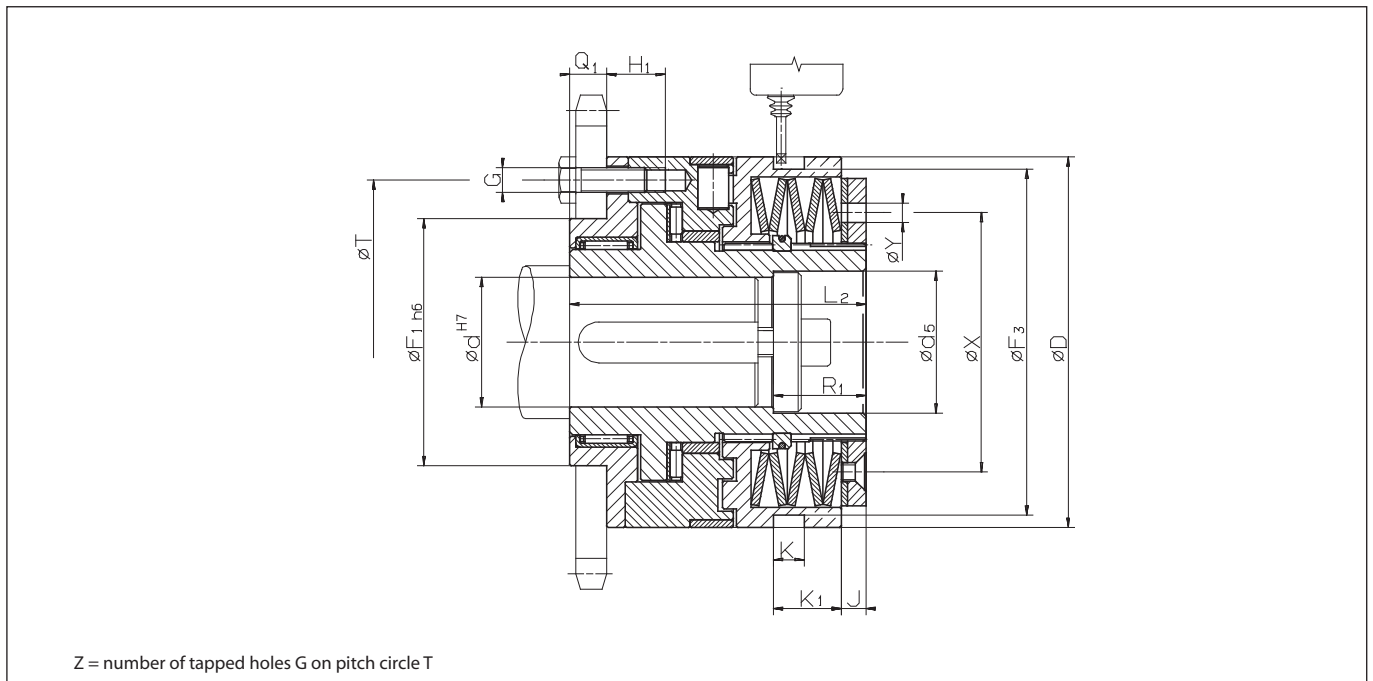

#### Technical Data

type	art. no.	torque type 1			torque type 2			torque type 3		
		limit torque Nm	max. speed min <sup>-1</sup>	end no.	limit torque Nm	max. speed min <sup>-1</sup>	end no.	limit torque Nm	max. speed min <sup>-1</sup>	end no.
SLR 32.x	4470.920.xxx	5 - 10	4000	701	10 - 20	4000	702	20 - 40	3000	703
SLR 40.x	4470.925.xxx	12 - 25	3900	701	25 - 50	3900	702	50 - 100	2900	703
SLR 55.x	4470.935.xxx	25 - 50	3300	701	50 - 100	3300	702	100 - 200	2400	703
SLR 65.x	4470.945.xxx	50 - 100	2800	701	100 - 200	2800	702	200 - 450	2000	703
SLR 80.x	4470.955.xxx	100 - 200	2300	701	200 - 400	2300	702	400 - 800	1600	703
SLR 90.x	4470.965.xxx	170 - 450	1800	701	350 - 900	1800	702	600 - 1800	1400	703

#### Dimensions

Type	Référence	bore d		d <sub>5</sub>	D	F <sub>1</sub>	F <sub>3</sub>	G	H <sub>1</sub>	J	K	K <sub>1</sub>	L <sub>2</sub>	Q <sub>1</sub>	R <sub>1</sub>	T	X	Y	Z	Course active
		min. mm	max. mm																	
SLR 32.x	4470.920.xxx	7	20	21	55	38	50	M5	11,5	3	9	13,5	51,5	8	15	48	38,5	5	6	0,6
SLR 40.x	4470.925.xxx	10	25	26	82	50	72,5	M5	16	6	9	14,5	70	10	20	70	54	6	6	0,8
SLR 55.x	4470.935.xxx	14	35	36	100	60	90,5	M6	15	6	9	15	78	12	25	89	70	6	6	1,1
SLR 65.x	4470.945.xxx	18	45	46	120	80	112	M8	18	8,5	10	22,5	96	12	30	105	84	6	6	1,2
SLR 80.x	4470.955.xxx	24	55	56	146	100	140	M10	23,5	11	9	25	124,5	16	30	125	108	7	6	1,2
SLR 90.x	4470.965.xxx	30	70 <sup>1)</sup>	66	176	120	170	M12	25,5	12	9	30	140	18	30	155	129	10	6	1,6

Keyway as per DIN 6885, page 1 · Tolerance of keyway width JS9

<sup>1)</sup>Keyway as per DIN 6885, page 3 · Tolerance of keyway width JS9

#### Example for Ordering

please indicate when ordering:	type	art. no.	preset limit torque	bore d	with proximity switch
	SLR 32. 1	4470.920. 701	9 Nm	18 mm	see p. 60 and 61

torque type  end no.

# Non-disengaging SIKUMAT with single rollers

## Series SLG - with long hub

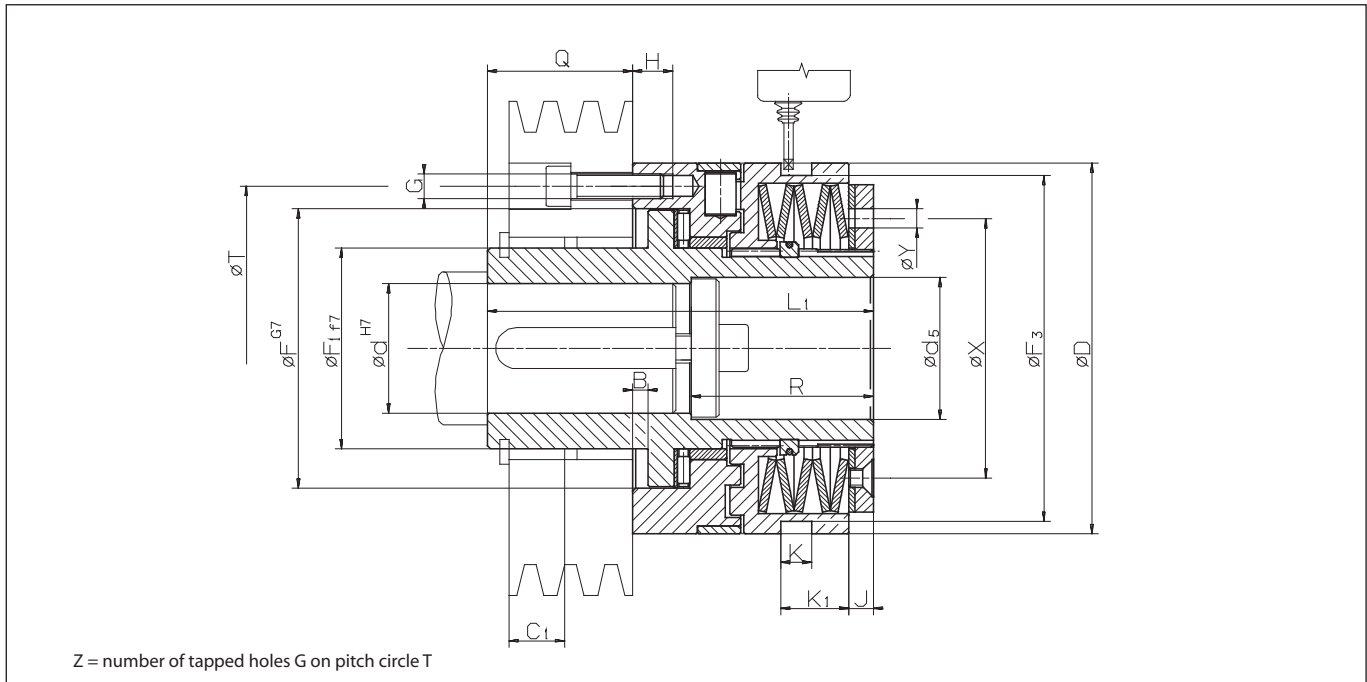

### Technical Data

type	art. no.	torque type 1			torque type 2			torque type 3		
		limit torque Nm	max. speed min <sup>-1</sup>	end no.	limit torque Nm	max. speed min <sup>-1</sup>	end no.	limit torque Nm	max. speed min <sup>-1</sup>	end no.
SLG 32.x	4470.120.xxx	5 - 10	4000	701	10 - 20	4000	702	20 - 40	3000	703
SLG 40.x	4470.125.xxx	12 - 25	3900	701	25 - 50	3900	702	50 - 100	2900	703
SLG 55.x	4470.135.xxx	25 - 50	3300	701	50 - 100	3300	702	100 - 200	2400	703
SLG 65.x	4470.145.xxx	50 - 100	2800	701	100 - 200	2800	702	200 - 450	2000	703
SLG 80.x	4470.155.xxx	100 - 200	2300	701	200 - 400	2300	702	400 - 800	1600	703
SLG 90.x	4470.165.xxx	170 - 450	1800	701	350 - 900	1800	702	600 - 1800	1400	703

### Dimensions

Type	Référence	bore d		d <sub>5</sub>	B	D	F	F <sub>1</sub>	F <sub>3</sub>	G	H	J	K	K <sub>1</sub>	L <sub>1</sub>	Q	R	T	X	Y	Z	Course active
		min. mm	max. mm																			
SLG 32.x	4470.120.xxx	7	20	21	4	55	41	28	50	M5	6,5	3	9	13,5	66	27,5	25,5	48	38,5	5	6	0,6
SLG 40.x	4470.125.xxx	10	25	26	4	82	60	38	72,5	M5	8	6	9	14,5	83	33	35	70	54	6	6	0,8
SLG 55.x	4470.135.xxx	14	35	36	5	100	78	52	90,5	M6	10	6	9	15	100	39	45	89	70	6	6	1,1
SLG 65.x	4470.145.xxx	18	45	46	5	120	90,5	65	112	M8	12	8,5	10	22,5	125	47	59	105	84	6	6	1,2
SLG 80.x	4470.155.xxx	24	55	56	6,5	146	105	78	140	M10	15	11	9	25	152,5	52,5	60	125	108	7	6	1,2
SLG 90.x	4470.165.xxx	30	70 <sup>1)</sup>	66	6,5	176	120,5	90	170	M12	17	12	9	30	171	57,5	60	155	129	10	6	1,6

Keyway as per DIN 6885, page 1 · Tolerance of keyway width JS9

<sup>1)</sup>Keyway as per DIN 6885, page 3 · Tolerance of keyway width JS9

### Example for Ordering

please indicate when ordering:	type	art. no.	preset limit torque	bore d	with proximity switch
	SLG 32. 1	4470.120. 701	9 Nm	14 mm	see p.60 and 61
	torque type <input type="checkbox"/>	end no. <input type="checkbox"/>			

# Non-disengaging SIKUMAT

## with single rollers

### Series SLE - with flexible shaft coupling

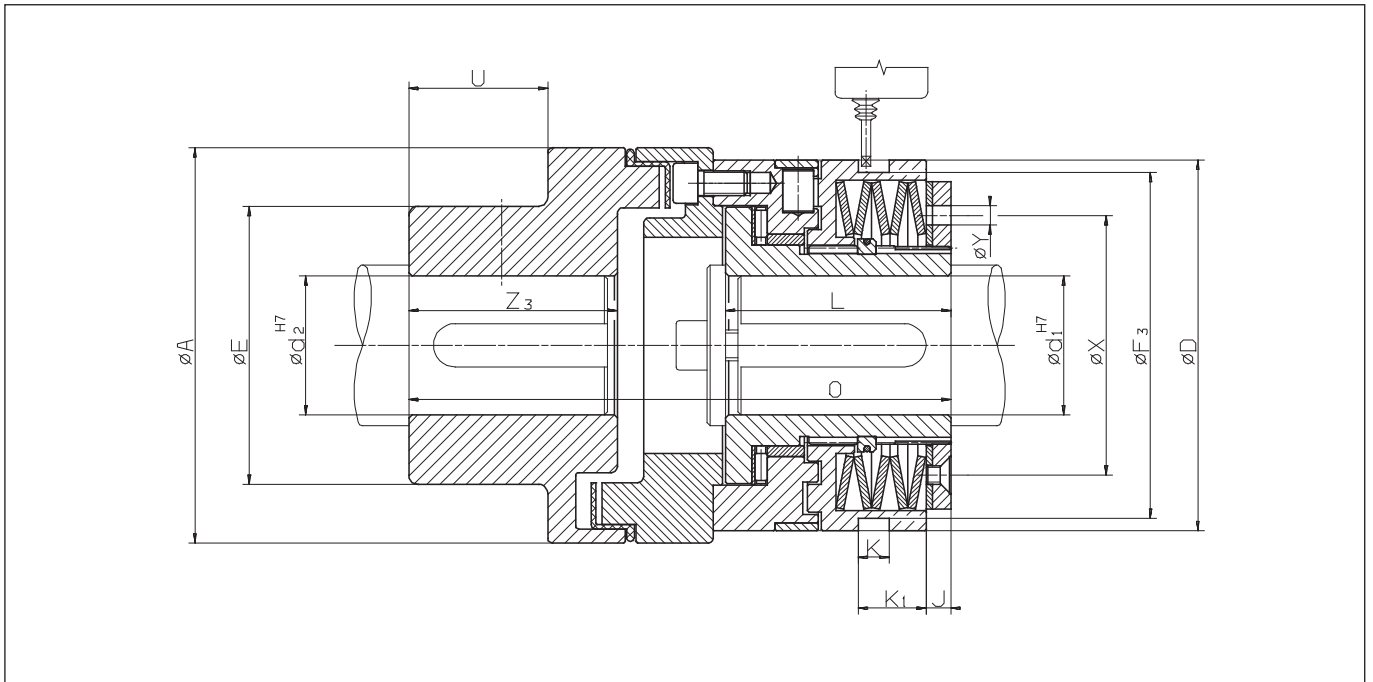

#### Technical Data

type	art. no.	torque type 1			torque type 2			torque type 3		
		limit torque Nm	max. speed min <sup>-1</sup>	end no.	limit torque Nm	max. speed min <sup>-1</sup>	end no.	limit torque Nm	max. speed min <sup>-1</sup>	end no.
SLE 32.x	4470.620.xxx	5 - 10	4000	701	10 - 20	4000	702	20 - 40	3000	703
SLE 40.x	4470.625.xxx	12 - 25	3900	701	25 - 50	3900	702	50 - 100	2900	703
SLE 55.x	4470.635.xxx	25 - 50	3300	701	50 - 100	3300	702	100 - 200	2400	703
SLE 65.x	4470.645.xxx	50 - 100	2800	701	100 - 200	2800	702	200 - 450	2000	703
SLE 80.x	4470.655.xxx	100 - 200	2300	701	200 - 400	2300	702	400 - 800	1600	703
SLE 90.x	4470.665.xxx	170 - 450	1800	701	350 - 900	1800	702	600 - 1800	1400	703

#### Dimensions

Type	Référence	bore		d <sub>2</sub> max. mm	A mm	E mm	D mm	F <sub>3</sub> mm	J mm	K mm	K <sub>1</sub> mm	L mm	O mm	U mm	X mm	Y mm	Z <sub>3</sub> mm	Course active mm
		min. mm	d <sub>1</sub> max. mm															
SLE 32.x	4470.620.xxx	7	20	30	67	46	55	50	3	9	13,5	35	86	15	38,5	5	28	0,6
SLE 40.x	4470.625.xxx	10	25	50	112	79	82	72,5	6	9	14,5	48	137,5	38	54	6	58	0,8
SLE 55.x	4470.635.xxx	14	35	50	112	79	100	90,5	6	9	15	56	147	38	70	6	58	1,1
SLE 65.x	4470.645.xxx	18	45	60	128	90	120	112	8,5	10	22,5	72	176,5	45	84	6	67	1,2
SLE 80.x	4470.655.xxx	24	55	60	148	90	146	140	11	9	25	93,5	211,5	45	108	7	67	1,2
SLE 90.x	4470.665.xxx	30	70 <sup>1)</sup>	70	177	107	176	170	12	9	30	107	242,5	52	129	10	75	1,6
SLE 90.3	4470.665.xxx	30	70 <sup>1)</sup>	90	198	140	176	170	12	9	30	107	272	52	129	10	75	3,0

Keyway as per DIN 6885, page 1 · Tolerance of keyway width JS9

<sup>1)</sup>Keyway as per DIN 6885, page 3 · Tolerance of keyway width JS9

#### Example for Ordering

please indicate when ordering:	type	art. no.	preset limit torque	bore d <sub>1</sub>	bore d <sub>2</sub>	with proximity switch
		SLE 32. 1	4470.620. 701	8 Nm	11 mm	21 mm

torque type  end no.

# Non-contact SIKUMAT Proximity Switch

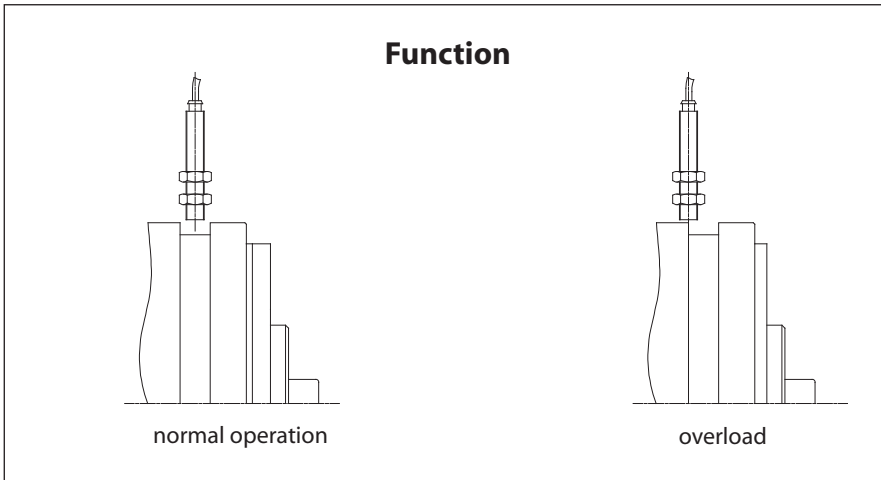

It is possible with SIKUMAT Torque Limiters to utilise the axial movement during an overload occurrence to actuate a proximity switch so that when the preset limit torque is exceeded, the drive can be switched off electrically and/or a signal can be triggered.

Switching off the drive in case of overload is essential for all ratcheting type SIKUMAT Torque Limiters in order to prevent ratcheting over prolonged periods and possible wear.

The engagement travel of the SIKUMAT Torque Limiters can be found in the respective tables.

Non-contact proximity switches operate free from wear and guarantee faster response times than mechanical limit sensors.

**DC**

Article number:	3504.000.072
Operating voltage:	24 V ± 25 %
NPN output	
Max. switching distance:	2 mm
Max. switching current:	200 mA
Switching frequency:	500 Hz
Mounting oscillation:	≤ 30 %
Output:	= 1 contact
Ambient temperature:	-25° ... +70° C
Connecting cable length:	2 m

**AC**

Article number:	3504.000.073
Operating voltage:	220 V
Electronic contact	
Max. switching distance:	5 mm
Switching frequency:	25 Hz
Ambient temperature:	-25° ... +70° C
Intermittent switching-on load at 220 V:	3 A
Min. required nominal load at 220 V:	5 mA
Permissible nominal load at 200 V:	200 mA
Repeat accuracy:	≤ 1 %
Connecting cable length:	2 m

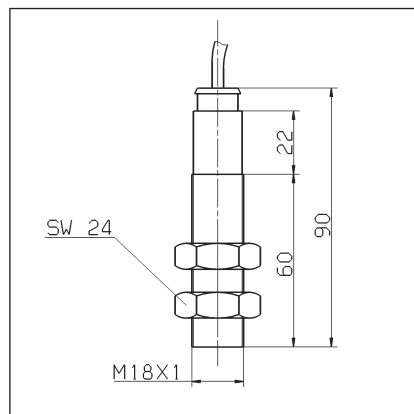
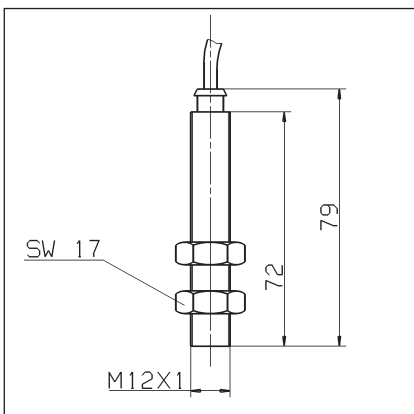

# Mechanical SIKUMAT Proximity Switch

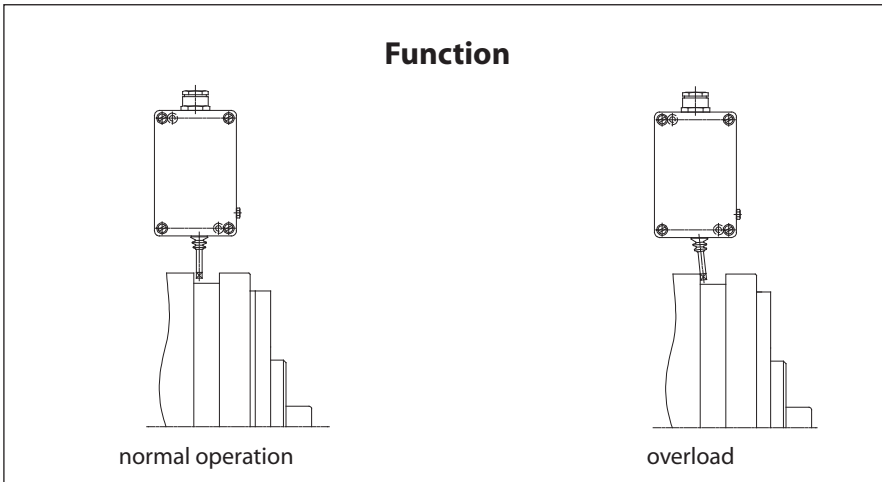

It is possible with SIKUMAT Torque Limiters to utilise the axial movement during an overload occurrence to actuate a proximity switch so that when the preset limit torque is exceeded, the drive can be switched off electrically and/or a signal can be triggered.

Switching off the drive in case of overload is essential for all ratcheting type SIKUMAT Torque Limiters in order to prevent ratcheting over prolonged periods and possible wear.

The engagement travel of the SIKUMAT Torque Limiters can be found in the respective tables.

The arm of the proximity switch should be positioned at a distance of 0,1 mm to the contact surface of the torque limiter.

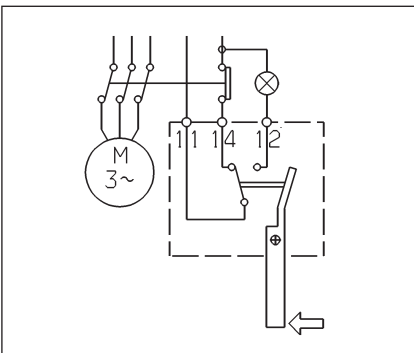
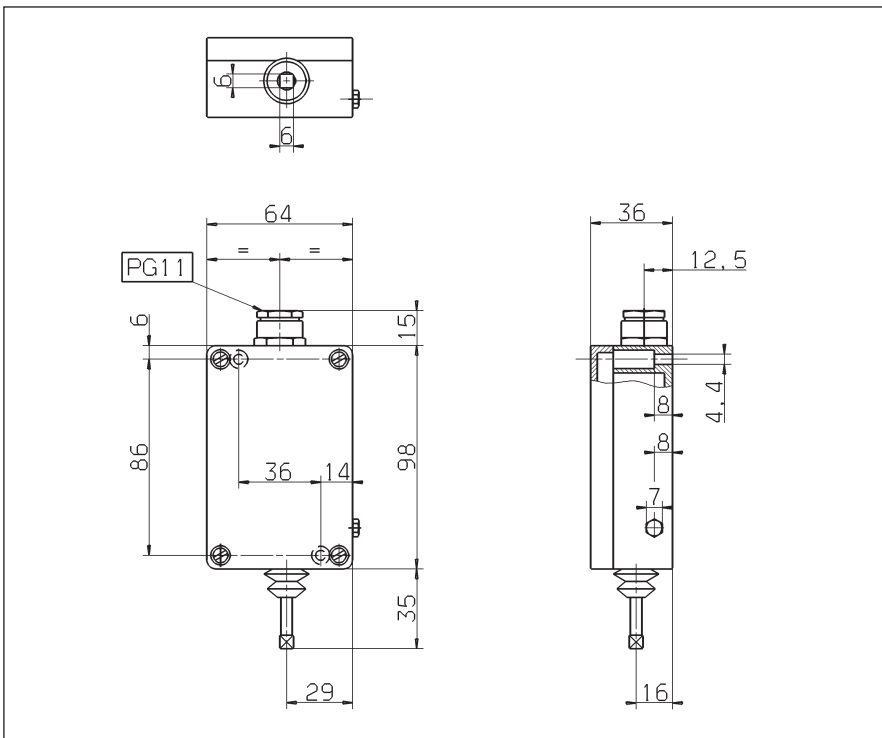

	system voltage V	rated current A
AC	250	15
DC	24	6
	60	1,5
	250	0,2

Article number:

3502.010.001.B240VW

Protection type:

IP 54

Ambient temperature: -25°...+70° C

Max. switching frequency:

3 Hz

# RIMOSTAT-Torque Limiters

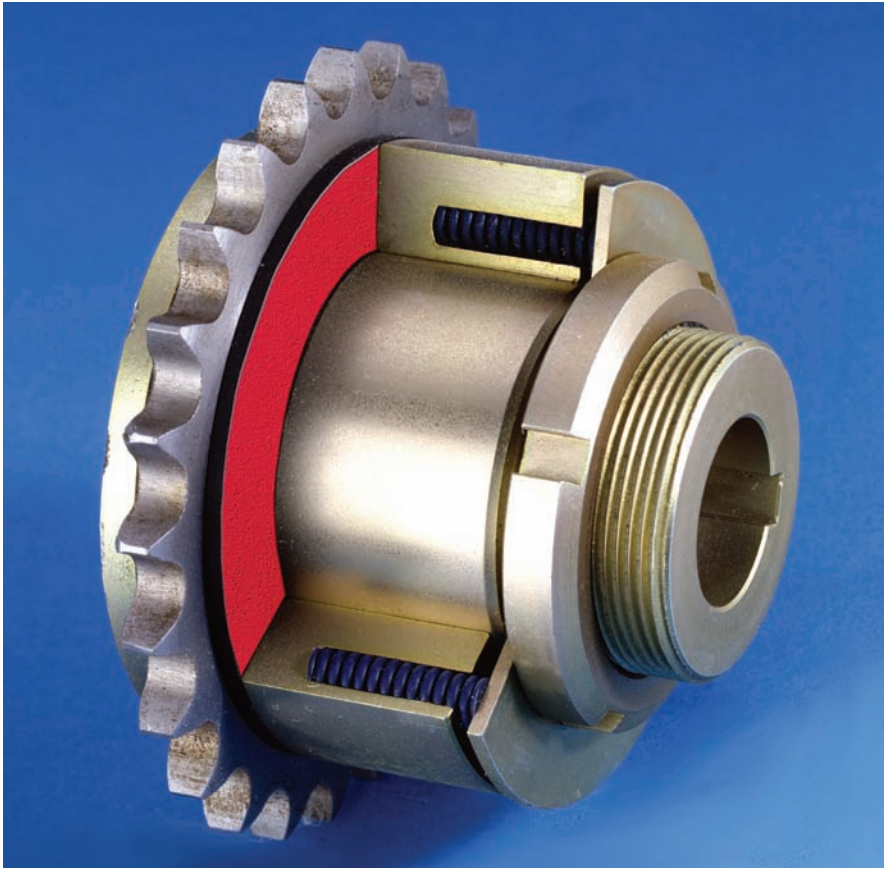

## The RIMOSTAT Principle

The contact pressure on the friction surfaces is produced by long coil springs. Because of the RIMOSTAT Torque Limiter's linear, flat-angle characteristic of the pressure force, practically no reduction of the limit torque occurs even when friction linings are subjected to wear. As the diagram shows, compared with Belleville spring torque limiters, assuming a friction wear of  $\Delta f$  the reduction of the limit torque  $\Delta M$  is negligible.

## Advantages

- Particularly suitable in applications with frequent slipping
- Better stability of limit torque than Belleville spring torque limiters over duration of the operating period
- Fixed detent protects against unauthorised adjustment of limit torque setting
- Combination with RINGSPANN speed monitor ESC creates an electro-mechanical safety system which emits electrical signals when a fault occurs in the operating process

## Function

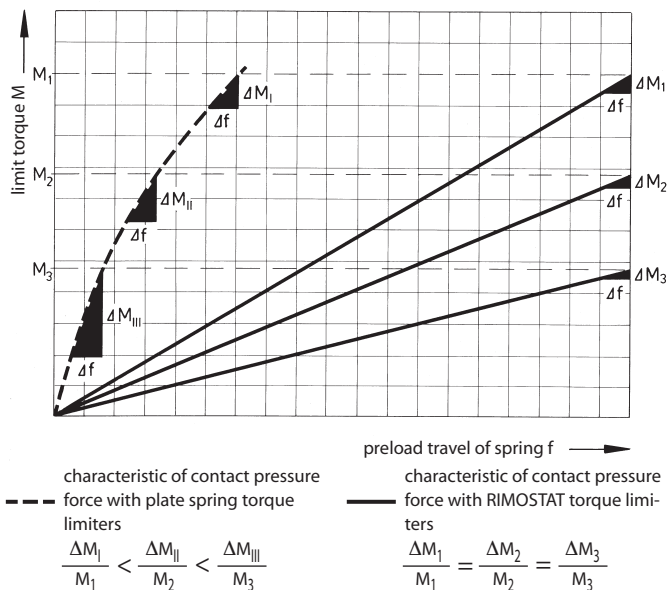
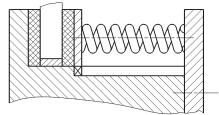

## Function

- When the preset limit torque has been reached the built-in component (e.g. chain wheel) slips.
- During the slipping process, input and output rotate relative to each other and the preset limit torque continues to be transmitted.
- Inherent in the slipping process is a high energy consumption.
- Re-engagement is not necessary.

# RIMOSTAT-Torque Limiters

## Series RS

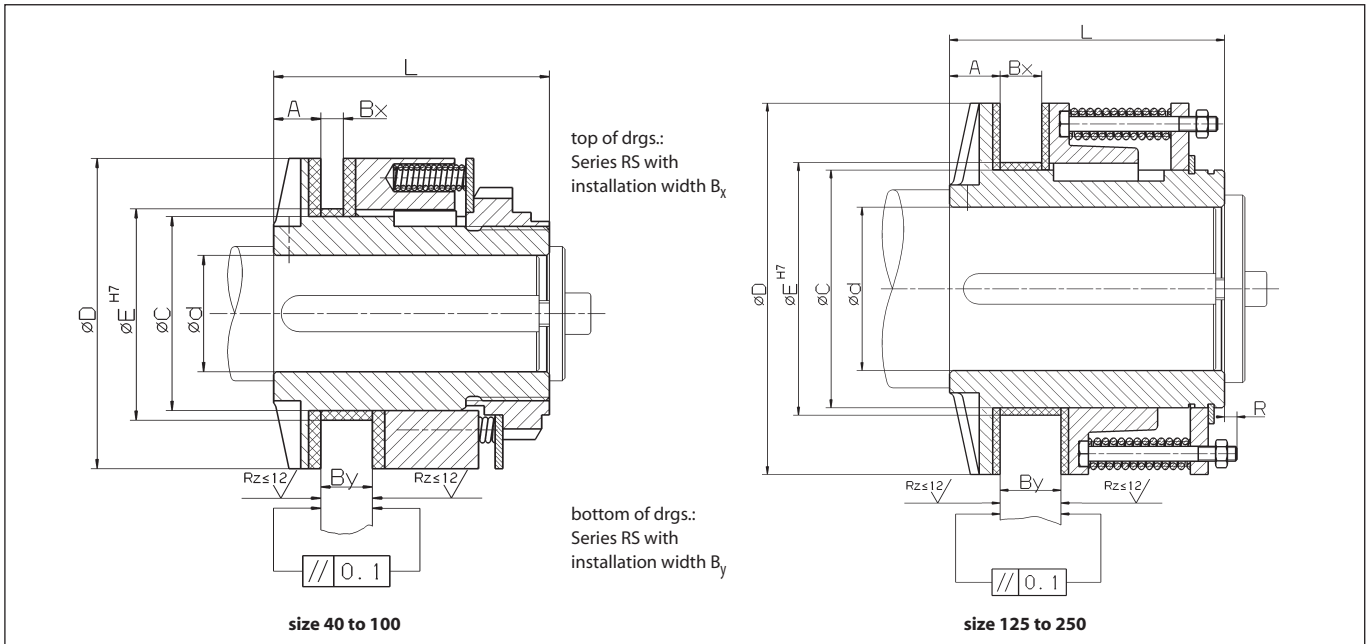

### Technical Data and Dimensions

type	art. no.	limit torque		max. speed <sup>1)</sup> min <sup>-1</sup>	bore $d^{H7}$		A mm	$B_x$ mm	$B_y$ mm	$C^2$ mm	D mm	$E^2$ mm	L mm	R mm
		Nm			min. mm	max. mm								
RS 40.1	4474.040.820	2 - 12		13 000	8	16	8	4,4	7	25	40	28	35,5	-
RS 40.2	4474.040.920	4 - 25		13 000	8	16	8	4,4	7	25	40	28	35,5	-
RS 50.1	4474.050.820	4 - 25		10 500	9	20	8	5,2	8,7	32	50	36	45	-
RS 50.2	4474.050.920	8 - 50		10 500	9	20	8	5,2	8,7	32	50	36	45	-
RS 63.1	4474.063.820	8 - 50		8 500	9	25	10	5,8	10,5	40	63	44	56	-
RS 63.2	4474.063.920	16 - 100		8 500	9	25	10	5,8	10,5	40	63	44	56	-
RS 80.1	4474.080.820	10 - 100		6 700	15	32	12	5,8	15,3	50	80	55	71	-
RS 80.2	4474.080.920	20 - 200		6 700	15	32	12	5,8	15,3	50	80	55	71	-
RS 100.1	4474.081.820	20 - 200		5 350	25	40	15	8,7	18	65	100	70	90	-
RS 100.2	4474.081.920	40 - 375		5 350	25	40	15	8,7	18	65	100	70	90	-
RS 125.1	4474.082.820	40 - 375		4 300	22	55	17	15,3	23	80	125	85	105	2,5
RS 125.2	4474.082.920	75 - 750		4 300	22	55	17	15,3	23	80	125	85	105	2,5
RS 160.1	4474.083.820	75 - 750		3 350	40	70	22	15,3	28	100	160	105	130	5,5
RS 160.2	4474.083.920	150 - 1 500		3 350	40	70	22	15,3	28	100	160	105	130	5,5
RS 200.1	4474.084.820	150 - 1 500		2 700	50	90	27	23	34	125	200	130	160	7,5
RS 200.2	4474.084.920	300 - 3 000		2 700	50	90	27	23	34	125	200	130	160	7,5
RS 250.1	4474.085.820	300 - 3 000		2 100	55	115	34	28	41	160	250	165	185	9,0
RS 250.2	4474.085.920	600 - 6 000		2 100	55	115	34	28	41	160	250	165	185	9,0

<sup>1)</sup> The max. speed relates to the design straight of the Torque Limiter; the max. permissible speed differential should be checked according to the heat calculation on page 68.

<sup>2)</sup> If the part to be coupled is used without bearing bush, the bore should be made to dimension C (tolerance F8).

Keyway as per DIN 6885, page 1 · Tolerance of keyway width P9

#### Width of parts to be connected:

Components may be connected with either width  $B_x$  or  $B_y$ .

#### Supply:

Unless requested otherwise, the Torque Limiters are supplied pilot bored, a full complement of springs, without torque setting and without bearing bush. Factory torque setting is only possible when the order includes a finish bore.

#### Accessories:

- Width  $B_x$  or  $B_y$  bearing bushes
- Standard tools are normally sufficient for adjusting the torque. Only sizes 125 and 160 require a tool adapter which can be ordered from us.
- RINGSPANN-Speed Control ESC

#### Please specify when ordering:

- Type of Torque Limiter
- Diameter  $d$ , if finish bore is requested
- Width of bearing bush  $B_x$  and  $B_y$
- Limit torque to be preset, if required

# RIMOSTAT-Torque Limiters

## Series RS - with sprockets

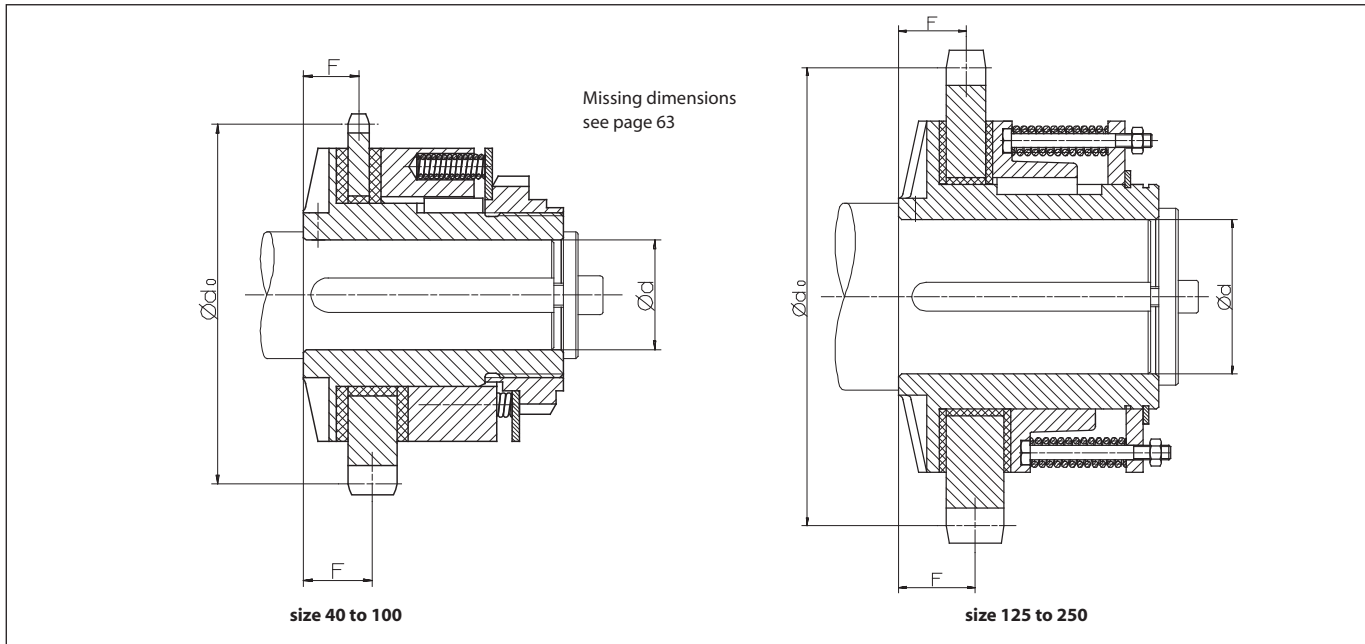

### Technical Data and Dimensions

type	art. no.	limit torque Nm	bore d <sup>H7</sup>		Chainwheel suitable for simple roller chain as per DIN							
			min. mm	max. mm	roller chain dimensions			n° of teeth Z	pitch circle-Ø d <sub>0</sub>	chainwheel- width B	F	
					pitch mm	inner width mm	roller-Ø mm					
RS 40.1	4474.040.822	2 - 12	8	16	9,525	x 4,77	x 5,08	17	51,8	4,4	10,2	
RS 40.2	4474.040.922	4 - 25	8	16	9,525	x 4,77	x 5,08	17	51,8	4,4	10,2	
RS 40.1	4474.040.823	2 - 12	8	16	12,7	x 7,75	x 8,51	14	57,1	7	11,5	
RS 40.2	4474.040.923	4 - 25	8	16	12,7	x 7,75	x 8,51	14	57,1	7	11,5	
RS 50.1	4474.050.821	4 - 25	9	20	9,525	x 5,72	x 6,35	20	60,9	5,2	10,6	
RS 50.2	4474.050.921	8 - 50	9	20	9,525	x 5,72	x 6,35	20	60,9	5,2	10,6	
RS 50.1	4474.050.823	4 - 25	9	20	15,87	x 9,65	x 10,16	14	71,3	8,7	12,4	
RS 50.2	4474.050.923	8 - 50	9	20	15,87	x 9,65	x 10,16	14	71,3	8,7	12,4	
RS 63.1	4474.063.822	8 - 50	9	25	12,7	x 6,4	x 8,51	20	81,2	5,8	12,9	
RS 63.2	4474.063.922	16 - 100	9	25	12,7	x 6,4	x 8,51	20	81,2	5,8	12,9	
RS 63.1	4474.063.823	8 - 50	9	25	19,05	x 11,68	x 12,07	14	85,6	10,5	15	
RS 63.2	4474.063.923	16 - 100	9	25	19,05	x 11,68	x 12,07	14	85,6	10,5	15	
RS 80.1	4474.080.822	10 - 100	15	32	12,7	x 6,4	x 8,51	23	93,3	5,8	15	
RS 80.2	4474.080.922	20 - 200	15	32	12,7	x 6,4	x 8,51	23	93,3	5,8	15	
RS 80.1	4474.080.823	10 - 100	15	32	25,4	x 17,02	x 15,88	13	106,1	15,3	19,8	
RS 80.2	4474.080.923	20 - 200	15	32	25,4	x 17,02	x 15,88	13	106,1	15,3	19,8	
RS 100.1	4474.081.821	20 - 200	25	40	15,87	x 9,65	x 10,16	24	121,6	8,7	19,5	
RS 100.2	4474.081.921	40 - 375	25	40	15,87	x 9,65	x 10,16	24	121,6	8,7	19,5	
RS 100.1	4474.081.823	20 - 200	25	40	31,75	x 19,56	x 19,05	13	132,7	18	24,1	
RS 100.2	4474.081.923	40 - 375	25	40	31,75	x 19,56	x 19,05	13	132,7	18	24,1	
RS 125.1	4474.082.821	40 - 375	22	55	25,4	x 17,02	x 15,88	19	154,3	15,3	24,8	
RS 125.2	4474.082.921	75 - 750	22	55	25,4	x 17,02	x 15,88	19	154,3	15,3	24,8	
RS 125.1	4474.082.823	40 - 375	22	55	38,1	x 25,4	x 25,4	14	171,2	23	28,7	
RS 125.2	4474.082.923	75 - 750	22	55	38,1	x 25,4	x 25,4	14	171,2	23	28,7	
RS 160.1	4474.083.821	75 - 750	40	70	25,4	x 17,02	x 15,88	23	186,5	15,3	29,7	
RS 160.2	4474.083.921	155 - 1.500	40	70	25,4	x 17,02	x 15,88	23	186,5	15,3	29,7	
RS 160.1	4474.083.823	75 - 750	40	70	50,8	x 30,99	x 29,21	13	212,3	28	36	
RS 160.2	4474.083.923	150 - 1.500	40	70	50,8	x 30,99	x 29,21	13	212,3	28	36	
RS 200.1	4474.084.821	150 - 1.500	50	90	38,1	x 25,4	x 25,4	20	243,6	23	38,5	
RS 200.2	4474.084.921	300 - 3.000	50	90	38,1	x 25,4	x 25,4	20	243,6	23	38,5	
RS 200.1	4474.084.823	150 - 1.500	50	90	63,5	x 38,1	x 39,37	13	265,4	34	44	
RS 200.2	4474.084.923	300 - 3.000	50	90	63,5	x 38,1	x 39,37	13	265,4	34	44	
RS 250.1	4474.085.821	300 - 3.000	55	115	44,45	x 30,99	x 27,94	21	298,3	28	48	
RS 250.2	4474.085.921	600 - 6.000	55	115	44,45	x 30,99	x 27,94	21	298,3	28	48	
RS 250.1	4474.085.823	300 - 3.000	55	115	76,2	x 45,72	x 48,26	14	342,4	41	54,5	
RS 250.2	4474.085.923	600 - 6.000	55	115	76,2	x 45,72	x 48,26	14	342,4	41	54,5	

Keyway as per DIN 6885, page 1 • Tolerance of keyway width P9

The glidebush is incorporated as standard. Further chainwheels available on request. Factory torque setting only possible for orders incl. finished bore. Further notes please refer to page 63.



# RIMOSTAT-Torque Limiters

## Series RSC - torque limiter with chain coupling

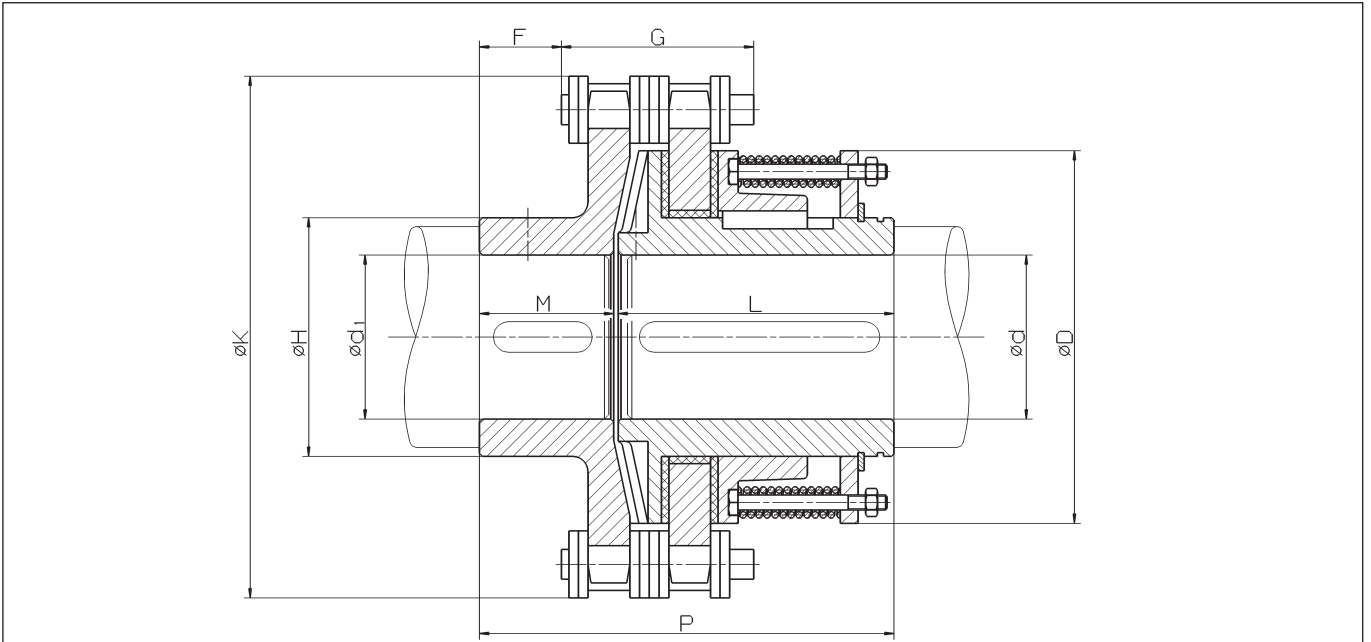

### Technical Data and Dimensions

type	art. no.	limit torque Nm	max. speed min <sup>-1</sup>	bore d <sup>H7</sup>		bore d <sub>1</sub> <sup>1)</sup>		D mm	F mm	G mm	H mm	K mm	L mm	M mm	P mm
				min. mm	max. mm	min. mm	max. mm								
RSC 40.1	4474.240.820	2 - 12	6.300	8	16	10	24	40	15	23	35	61	35,5	19	55,5
RSC 40.2	4474.240.920	4 - 25	6.300	8	16	10	24	40	15	23	35	61	35,5	19	55,5
RSC 50.1	4474.250.820	4 - 25	5.300	9	20	13	30	50	16	25	45	70	45	21,5	67,5
RSC 50.2	4474.250.920	8 - 50	5.300	9	20	13	30	50	16	25	45	70	45	21,5	67,5
RSC 63.1	4474.263.820	8 - 50	4.250	9	25	17	44	63	17	33	60	94	56	25,5	83
RSC 63.2	4474.263.920	16 - 100	4.250	9	25	17	44	63	17	33	60	94	56	25,5	83
RSC 80.1	4474.280.820	10 - 100	3.350	15	32	17	50	80	19	33	70	106	71	24	97
RSC 80.2	4474.280.920	20 - 200	3.350	15	32	17	50	80	19	33	70	106	71	24	97
RSC 100.1	4474.281.820	20 - 200	2.650	25	40	17	58	100	25	38	80	137	90	30	123
RSC 100.2	4474.281.920	40 - 375	2.650	25	40	17	58	100	25	38	80	137	90	30	123
RSC 125.1	4474.282.820	40 - 375	2.120	22	55	26	75	125	25	75	100	180	105	46,5	154,5
RSC 125.2	4474.282.920	75 - 750	2.120	22	55	26	75	125	25	75	100	180	105	46,5	154,5
RSC 160.1	4474.283.820	75 - 750	1.700	40	70	26	82	160	35	75	110	211	130	51,5	184,5
RSC 160.2	4474.283.920	150 - 1.500	1.700	40	70	26	82	160	35	75	110	211	130	51,5	184,5
RSC 200.1	4474.284.820	150 - 1.500	1.320	50	90	26	105	200	37	113	140	280	160	70	233
RSC 200.2	4474.284.920	300 - 3.000	1.320	50	90	26	105	200	37	113	140	280	160	70	233
RSC 250.1	4474.285.820	300 - 3.000	1.120	55	115	26	120	250	55	129	160	336	185	90	280
RSC 250.2	4474.285.920	600 - 6.000	1.120	55	115	26	120	250	55	129	160	336	185	90	280

<sup>1)</sup> Check the stress of the keyway in the case of smaller finish bores d<sub>1</sub> and high torques  
Keyway according to DIN 6885, p.1 · Tolerance of keyway width P9

#### Application:

As slipping shaft coupling to compensate for minor misalignments.

#### Supply:

Unless specified otherwise, the Torque Limiters are supplied with a pilot bore, a full complement of springs and without torque setting. Factory torque setting is only possible when the order includes a finish bore.

#### Accessories:

- Standard tools are normally sufficient for adjusting the torque. Only sizes 125 and 160 require a tool adapter which can be ordered from us.
- RINGSPANN speed monitor ESC

#### Please specify when ordering:

- Type of Torque Limiting chain coupling
- Diameter d, if finish bore is requested
- Limit torque to be preset, if required

# Belleville Spring Torque Limiters

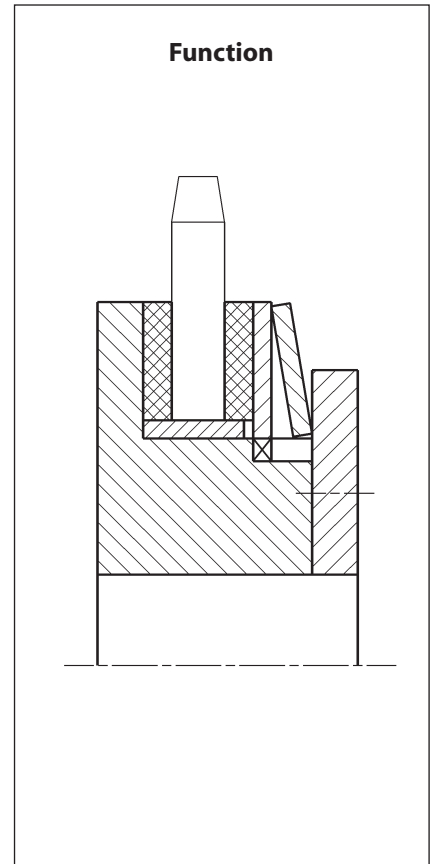
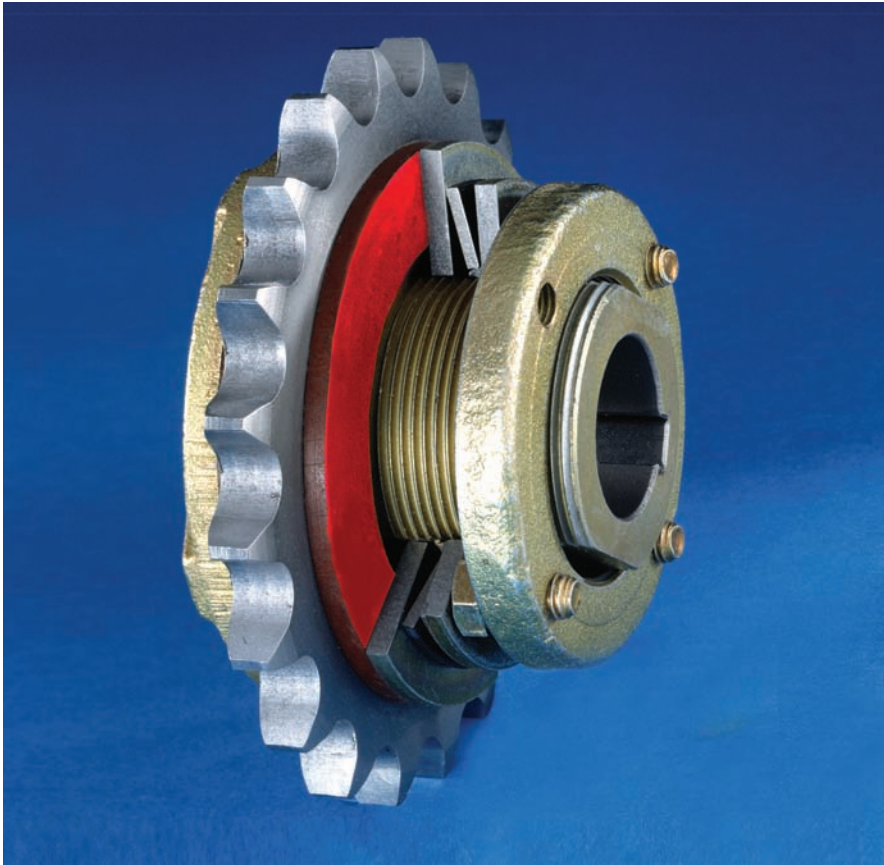

## The Belleville Spring Principle

Belleville springs produce the contact force on the friction linings. Because of the Belleville spring torque limiters' steep characteristic of the contact force the spring preload needs to be readjusted when the friction linings become worn. Belleville spring Torque Limiters are therefore preferred in applications where slipping periods are short and infrequent.

## Advantages

- Cost effective, simple Torque Limiter
- Sizes for torques from 0.5 Nm to 10 000 Nm
- Combination with RINGSPANN speed monitor ESC creates an electro-mechanical safety system which emits electrical signals when a fault occurs in the operating process; see catalogue 50.1 for further details

## Function

- When the preset limit torque has been reached the built-in component (e.g. chain wheel) slips.
- During the slipping process, input and output rotate relative to each other and the preset limit torque continues to be transmitted.
- Inherent in the slipping process is a high energy consumption.
- Re-engagement is not necessary.

# Belleville Spring Torque Limiters

## Series RT

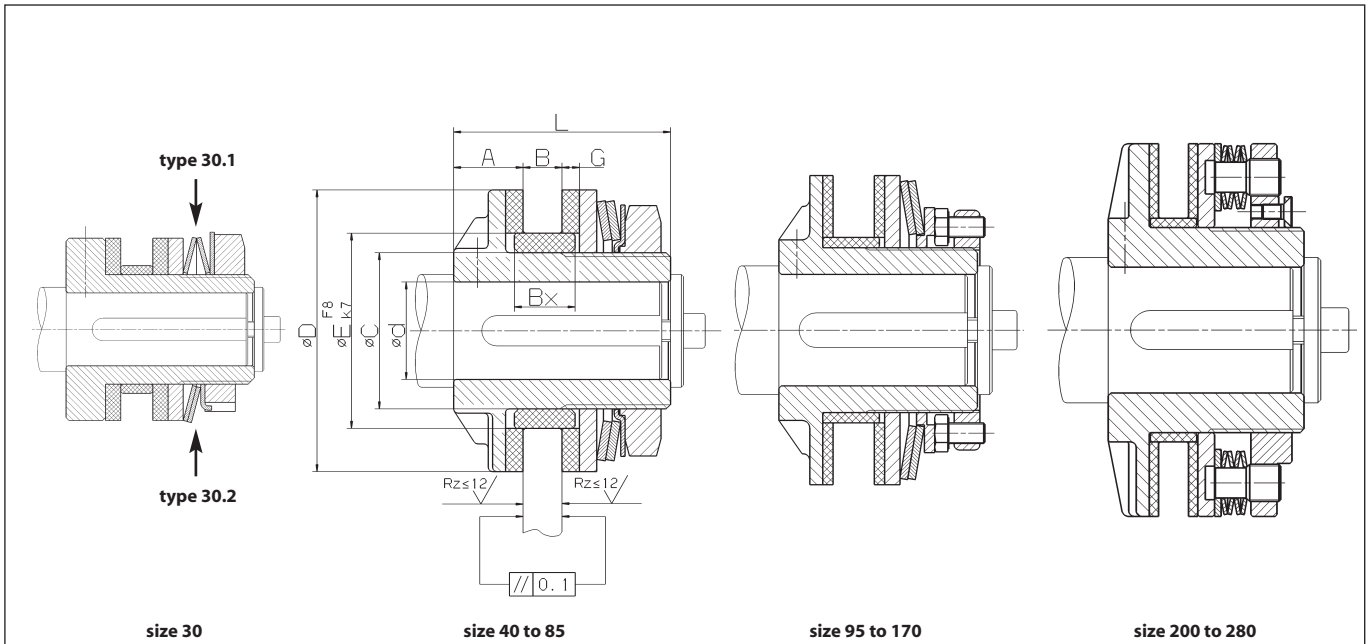

### Technical Data and Dimensions

type	art. no.	limit torque Nm	max. speed min <sup>-1</sup>	bore			A mm	B max. mm	B <sub>X</sub> <sup>3)</sup> mm	C mm	D mm	E mm	L mm	G mm
				min. <sup>1)</sup> mm	max. <sup>1)</sup> mm	max. <sup>2)</sup> mm								
RT 30.1	4476.003.001	0,5 - 5	1.500	5,5	11	12	9	6	6	18	30	21	31	2,5
RT 30.2	4476.003.002	1,0 - 10	1.500	5,5	11	12	9	6	6	18	30	21	31	2,5
RT 40.1	4476.004.001	5 - 15	800	8	14	16	8	7	8	22	40	26	28	2,8
RT 40.2	4476.004.002	8 - 28	800	8	14	16	8	7	8	22	40	26	28	2,8
RT 40.3	4476.004.003	12 - 40	800	8	14	16	8	7	8	22	40	26	28	2,8
RT 45.1	4476.004.501	9 - 30	700	8	20	22	8,5	8	9	32	45	35	33	3
RT 45.2	4476.004.502	14 - 55	700	8	20	22	8,5	8	9	32	45	35	33	3
RT 45.3	4476.004.503	15 - 70	700	8	20	22	8,5	8	9	32	45	35	33	3
RT 65.1	4476.006.501	20 - 70	700	11	22	25	16	13	14	36	65	45	50	4
RT 65.2	4476.006.502	32 - 120	700	11	22	25	16	13	14	36	65	45	50	4
RT 85.1	4476.008.501	16 - 130	600	16	30	30	17	15	16	42	85	52	55	4
RT 85.2	4476.008.502	26 - 240	600	16	30	30	17	15	16	42	85	52	55	4
RT 95.1	4476.009.501	22 - 190	600	16	35	38	18	15	16	52	95	60	66	4
RT 95.2	4476.009.502	32 - 340	600	16	35	38	18	15	16	52	95	60	66	4
RT 120.1	4476.012.001	25 - 350	500	21	45	48	21	20	21	64	120	73	77	4
RT 120.2	4476.012.002	48 - 650	500	21	45	48	21	20	21	64	120	73	77	4
RT 140.1	4476.014.001	110 - 650	400	21	60	60	23	20	22	85	140	90	86	4
RT 140.2	4476.014.002	125 - 1.200	400	21	60	60	23	20	22	85	140	90	86	4
RT 170.1	4476.017.001	80 - 1.000	350	29	65	70	26,5	20	24	90	170	100	93	4,6
RT 170.2	4476.017.002	200 - 1.800	350	29	65	70	26,5	20	24	90	170	100	93	4,6
RT 200.1	4476.020.001	636 - 2.200	250	37	80	80	27	20	24	110	200	120	105	5
RT 200.2	4476.020.002	890 - 4.000	250	37	80	80	27	20	24	110	200	120	105	5
RT 254.1	4476.025.401	1145 - 3.800	200	50	90	100	33	29	32	125	254	140	120	5
RT 254.2	4476.025.402	2067 - 6.800	200	50	90	100	33	29	32	125	254	140	120	5
RT 280.1	4476.028.001	1510 - 5.500	180	50	120	120	33	29	32	155	280	170	120	5
RT 280.2	4476.028.002	2544 - 10.000	180	50	120	120	33	29	32	155	280	170	120	5

<sup>1)</sup>Keyway as per DIN 6885, page 1 · Tolerance of keyway width P9

<sup>2)</sup>Keyway as per DIN 6885, page 3 · Tolerance of keyway width P9

<sup>3)</sup>If B+G+1,5 mm > B<sub>X</sub>, than use 2 bearings bushes (does not apply to RT30.X).

#### Supply:

Unless specified otherwise, the Torque Limiters are supplied with a pilot bore, including plain bearing and friction linings.

#### Accessories:

- All sizes available with chain wheel
- RINGSPANN-Speed Control ESC

#### Please specify when ordering:

- Type of Torque Limiter
- Diameter d, if finish bore is requested

# Calculation of RIMOSTAT Torque Limiters

## Symbols

$M_L$ [Nm]	Torque requirement of machine whilst operating	$n$ [r.p.m.]	Speed when driving half is running at nominal speed	$J$ [kgm <sup>2</sup> ]	Mass inertia moment of rotating masses to be accelerated, relative to the speed of the torque limiter
$M_{La}$ [Nm]	Average starting torque of machine	$n_a$ [r.p.m.]	Speed when torque limiter is slipping (driven half)	$P_R$ $\left[ \frac{\text{Nm}}{\text{s}} = \text{W} \right]$	Standard-friction power
$M_K$ [Nm]	Preset friction slip torque of torque limiter	$\Delta n$ [r.p.m.]	Speed differential between input and output	$P_a$ $\left[ \frac{\text{Nm}}{\text{s}} = \text{W} \right]$	Occuring friction power
$P_L$ [kW]	Rate of power input of driving half	$t_a$ [s]	Slipping time (see 2.1)	$P_{zul.}$ $\left[ \frac{\text{Nm}}{\text{s}} = \text{W} \right]$	Max. permissible friction power

## Selection

Below are the basic guidelines to be applied for the selection of RIMOSTAT Torque Limiters:

- If slipping periods are short and very infrequent, the highest transmissible table torque may be utilised.
- For infrequent but longer slipping periods the heat factor should be checked against diagram 1.
- For constant friction or frequent, very short slipping periods the heat factor should be checked against diagram 2.

Selection of RIMOSTAT Torque Limiters is carried out of three stages:

1. Selection according to required torque
2. Evaluation of slipping period and speed differential
3. Checking the heat factor

### 1. Selection according to required torque load

The torque to be transmitted by the RIMOSTAT Torque Limiter is to be taken from the tables, as is the permissible speed.

The preset slip torque  $M_K$  must exceed the peak starting torque by at least 25% and must be at least 25% higher than the normal running torque  $M_L$  of the installation to be driven

The required operating torque can be calculated from the power absorption of the machine:

$$M_L = 9550 \cdot \frac{P_L}{n} \quad [\text{Nm}] \quad (1)$$

### Calculation of slipping period and friction power

#### 2.1 Application as starter coupling

$$t_a = \frac{J \cdot n}{9,55 (M_K - M_{La})} \quad [\text{s}] \quad (2)$$

For conversion of the old Technical Standard System apply  $J \triangleq 0,25 \cdot GD^2$ , entering  $GD^2$  as  $\text{kpm}^2$ .

The average starting torque  $M_{La}$  of the machine or installation during the starting process depends on the type of machine.

For example, in the case of conveyor installations which are started while under load, the torque requirement during the starting process is, after overcoming the breakaway torque requirement during operation, i.e.  $M_{La} = M_L$ . In the case of ventilators the torque requirement at the beginning of the starting process can be very low and increases during starting process with  $n^2$  i.e. approximately  $M_{La} = 0,5 \cdot M_L$ .

The differential speed  $\Delta n$  changes during the starting process from  $n$  (at the beginning of the starting process) to 0 (after ending the starting process).

One can therefore apply the following calculation to determine the heat:

$$\Delta n = \frac{n}{2} \quad [\text{r.p.m.}] \quad (3)$$

## 2.2 Application as safety coupling

Slipping time can be limited by safety devices, e.g.:

- Speed monitors which disengage the motor when different speeds between input and output of the torque limiter occur
- Thermal motor monitoring units
- Optical control (manual disengagement)

Assuming the driving side is blocked and the motor continues to run at full speed, the differential speed would amount to

$$\Delta n = n \quad [\text{r.p.m.}] \quad (4)$$

## 2.3 Friction Power

The occurring friction power is calculated as follows:

$$P_a = 0,105 \cdot M_K \cdot \Delta n \quad [\text{W}] \quad (5)$$

## 3. Checking the heat factor

### 3.1 Application as starter- or safety coupling

Using the calculated slipping time  $t_a$  the standard friction power  $P_R$  is taken from diagram 1 and multiplied with size factor K according to the table. The resulting friction power  $P_{zul}$  of the selected torque limiter must be greater than the occurring friction power  $P_a$ .

Full utilisation of the maximum permissible friction power  $P_{zul}$  at an ambient temperature of 20° C causes the torque limiter to heat to ca. 220° C.

size	size factor (K)
RS 40	0,13
RS 50	0,21
RS 63	0,35
RS 80	0,6
RS 100	1,0
RS 125	1,7
RS 160	2,9
RS 200	5,1
RS 250	7,5

### 3.2 Application as permanent slipping hub

The occurring friction power  $P_a$  must be calculated using formula (5).

It must be lower than the maximum transmissible friction power  $P_{zul}$  of

the given speed of the spring support  $n_a$ , as shown in diagram 2.

Diagram 1

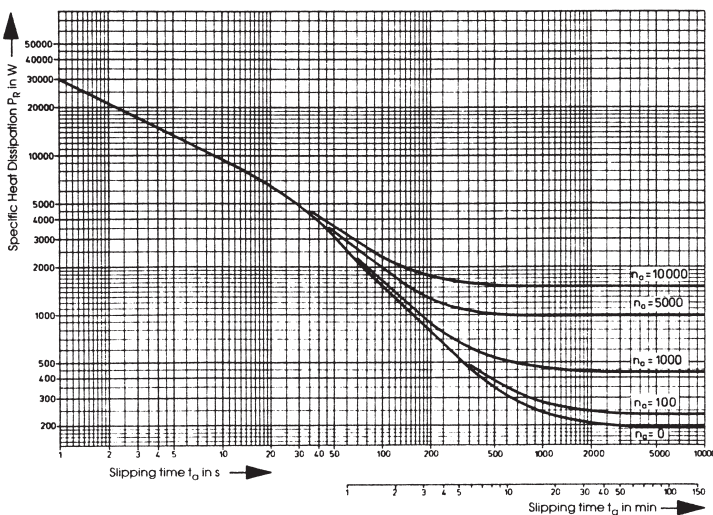
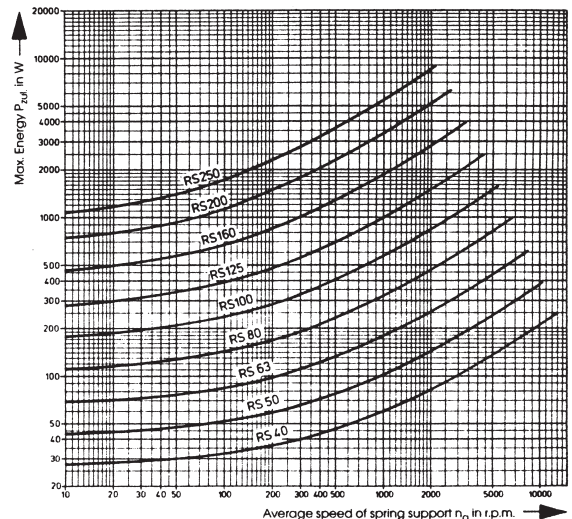

Diagram 2 (ambient temperature 20° C)



# Comparison Table of current Torque Limiters

mayr	KTR	Hausmann + Haensgen	WARNER ELECTRIC	RINGSPANN
- - -	- - -	- - -	- - -	<b>Ratcheting SIKUMAT with screw faces</b> Series SC Series SCE Series SCL
<b>EAS Ratcheting coupling</b>  Type 400_00.0 Type 400_00.5 Type 400_00.1 Type 437_00.0	<b>KTR-SI DK</b>  Type FT Type KT Type LT Type FT with ROTEX®	<b>Hatorq-Indexing-couplings</b>  Type A Type B Type C Type DA __ Bipex __	<b>Warner Series 340</b>  L_A_Series 340 L_B_Series 340 L_C_Series 340 L_A_Series 340-05	<b>Ratcheting SIKUMAT with ball</b>  Series SG Series SGR Series SGG Series SGE
<b>EAS-compact Ratcheting coupling</b>  Type 490_10.0 Type 490_10.1 Type 494_10_ Type 493_10.0	<b>KTR-SI-Compact DK</b>  Type FT 4.5 - Type FT 4.5 with ROTEX® GS Type FT 4.5 with RADEX®-NC	<b>Hatorq-SSK-Compact Indexing-couplings</b>  Type A Type C - -	- - - -	<b>Ratcheting SIKUMAT - Backlash free with balls</b>  Series ST Series STG Series STE Series STL
<b>EAS Synchronous coupling</b>  Type 400_05.0 Type 400_05.5 Type 400_05.1 Type 437_05.0	<b>KTR-SI SR</b>  Type FT Type KT Type LT Type FT with ROTEX®	<b>Hatorq-Synchronous-couplings</b>  Type A Type B Type C -	<b>Warner Series 350</b>  L_A_Series 350 L_B_Series 350 L_C_Series 350 L_A_Series 350-05	<b>Synchronous Ratcheting SIKUMAT with single rollers</b>  Series SN Series SNR Series SNG Series SNE
- - -	- - -	- - -	- - -	<b>Synchronous Ratcheting SIKUMAT with double rollers</b>  Series SA Series SAG Series SAE Series SAL
<b>EAS-compact Synchronous coupling</b>  Type 490_15.0 Type 490_15.1 Type 494_15_ Type 493_15.0	<b>KTR-SI-Compact SR</b>  Type FT 4.5 - Type FT 4.5 with ROTEX® GS Type FT 4.5 with RADEX®-NC	<b>Hatorq-SSK-Compact Synchronous-couplings</b>  Type A Type C - -	- - - -	<b>Synchronous Ratcheting SIKUMAT - Backlash free with balls</b>  Series SU Series SUG Series SUE Series SUL
<b>EAS-Free switching</b>  Type 400_14.0 Type 400_14.5 Type 400_14.1 Type 437_14.0	- - - -	<b>Hatorq-Synchronous-couplings</b>  Type A Type B Type C -	- - - -	<b>Disengaging SIKUMAT with single rollers</b>  Series SR Series SRR Series SRG Series SRE
- - -	- - -	- - -	- - -	<b>Synchronous Disengaging SIKUMAT with double rollers</b>  Series SB Series SBG Series SBE Series SBL
<b>EAS-locking coupling</b>  Type 400_01.0 Type 400_01.5 Type 400_01.1 Type 437_01.0	<b>KTR-SI SGR</b>  Type FT Type KT Type LT Type FT with ROTEX®	<b>Hatorq-Locked-couplings</b>  Type A Type B Type C -	<b>Warner Series 350</b>  L_A_Series 360 L_B_Series 360 L_C_Series 360 L_A_Series 360-05	<b>Locking-SIKUMAT with single rollers</b>  Series SL Series SLR Series SLG Series SLE
-	-	-	-	<b>RIMOSTAT-Torque Limiter</b> Series RS
-	-	<b>Hatorq-Torque Limiter</b> Type T	<b>Warner Series 300</b> L_ _ Series 300	<b>Belleville Spring Torque Lim.</b> Series RT

These torque limiters are comparable in their main connecting dimensions.

# Questionnaire for the selection of RINGSPANN Torque Limiters

please photocopy

Company: ..... Address: ..... Telephone: ..... Telefax: .....	Department: ..... Name: ..... Enquiry no.: ..... Date: ..... e-mail: .....
<b>1. Type of machine, machine group or plant into which torque limiter is to be installed</b> ..... ..... .....	
<b>2. Effect</b> Torque limiting through:      Re-engagement : <input type="checkbox"/> Ratcheting <input type="checkbox"/> Automatic <input type="checkbox"/> Automatic-synchronous after 360° <input type="checkbox"/> Disengaging <input type="checkbox"/> Manual <input type="checkbox"/> Manual-synchronous after 360° <input type="checkbox"/> Slipping	
<b>3. Backlash free torque transmission required?</b> <input type="checkbox"/> yes <input type="checkbox"/> no	
<b>4. Arrangement as</b> <input type="checkbox"/> Shaft coupling (with co-axial shafts) Input side:    Shaft diameter ..... mm Length ..... mm Output side: Shaft diameter ..... mm Length ..... mm  <input type="checkbox"/> Built-on coupling, on <input type="checkbox"/> Shaft end:        Diameter ..... mm Length ..... mm <input type="checkbox"/> Through-shaft dia.: Diameter ..... mm Length ..... mm  Torque Limiter connects shaft with <input type="checkbox"/> Gear wheel <input type="checkbox"/> Chain wheel <input type="checkbox"/> Pulley <input type="checkbox"/> Other .....	
<b>5. Drive via</b> <input type="checkbox"/> A-synchronous motor <input type="checkbox"/> Direct drive <input type="checkbox"/> *-Δ-[Star-delta] drive <input type="checkbox"/> Other electric motor, type:.....  <input type="checkbox"/> Combustion engine Type ..... No. of cylinders ..... <input type="checkbox"/> Other .....	
<b>6. Output and speed</b> Output power ..... kW Speed of torque limiter ..... min <sup>-1</sup> <input type="checkbox"/> Total output power via torque limiter <input type="checkbox"/> Output power only up to .....% via torque limiter	
<b>7. Output side</b> Part of machine driven by the torque limiter ..... Required torque load ..... Nm <input type="checkbox"/> In case of irregular torque requirement: from ..... Nm to ..... Nm, frequency ..... Hz During starting a maximum torque of ..... Nm may occur How often will an overload occur? ..... times per year Preset limit Torque ..... Nm (Limit torque must be 15% above maximum operating torque)	
<b>8. Installation conditions</b> <input type="checkbox"/> In enclosed machine housing <input type="checkbox"/> Exposed, but in enclosed space <input type="checkbox"/> In oil bath or oil fog <input type="checkbox"/> Outside, ambient temperatures from ..... to .....°C <input type="checkbox"/> Other (accessibility, dust, etc.): .....  <input type="checkbox"/> If arranged as shaft coupling: Max. parallel displacement of shafts: ..... mm Max. angular displacement: ..... degrees Distance between shaft ends: ..... mm	
<b>9. Overload signal by</b> <input type="checkbox"/> Non-contact proximity switch <input type="checkbox"/> Mechanical proximity switch  <input type="checkbox"/> Speed control ESC <input type="checkbox"/> Not necessary	
<b>For the selection of the torque limiter particular consideration should be given to the following:</b> ..... Estimated requirement:    ..... Units (one off)                      ..... Units per month                      ..... Units per year	



# RINGSPANN®

## Power Transmission

### Freewheels

#### Backstops

Automatic protection against reverse running of conveyor belts, elevators, pumps and fans.

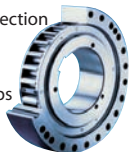

Catalogue 88

#### Overrunning Clutches

Automatic engaging and disengaging of drives.



Catalogue 80

#### Indexing Freewheels

For gradual feed of materials.



Catalogue 80

#### Housing Freewheels

Automatic engaging and disengaging for multi-motor drives for installations with continuous operation.



Catalogue 80.1

#### Freewheel Elements

Cage Freewheels, Sprag Sets and Freewheel Chains.



Catalogue 89

### Brakes

#### Industrial Disc Brakes

Manually actuated – manually released.



Catalogue 46

#### Industrial Disc Brakes

Spring actuated – pneumatically, hydraulically or manually released.

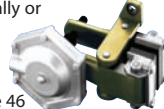

Catalogue 46

#### Industrial Disc Brakes

Spring actuated – electromagnetically released.

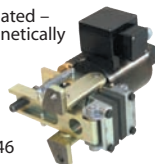

Catalogue 46

#### Industrial Disc Brakes

Pneumatically actuated – spring released.



Catalogue 46

#### Industrial Disc Brakes

Hydraulically actuated – spring released.



Catalogue 46

### Torque and Force Limiters

#### Torque Limiters with Screw Face

Reliable overload protection for tough operating conditions.



Catalogue 45

#### Torque Limiters with Rollers

With double or single Rollers. Through ratcheting or disengaging, also for 360° synchronous running.



Catalogue 45

#### Torque Limiters with Balls

Reliable overload protection with maximum response accuracy. Also backlash free.



Catalogue 45

#### Torque Limiters with Friction Linings

RIMOSTAT Torque Limiter for constant torque. Belleville Spring Torque Limiter for simple release.



Catalogue 45

#### Force Limiters

Reliable axial overload protection in piston rods.



Catalogue 49

### Couplings and Clamping Clutches

#### Flexible Couplings

Large, allowed radial and angular misalignments. Minimum resiliency.



Catalogue 44

#### Flange-Couplings

Rigid, easily removable shaft coupling with no clearance cone clamping elements.



E04.020

#### Clamping Clutches

For the automatic coupling of rolls. Fast, safe and free from slipping connection.



Catalogue 45

#### Safety Clamping Units pneumatically released

For secure and precise positioning of piston rods.

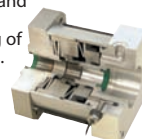

E01.023

#### Safety Clamping Units hydraulically released

For secure and precise positioning of piston rods.

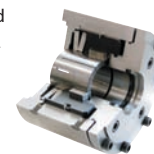

Catalogue 32

### Shaft-Hub-Connections

#### Two-part Shrink Discs

External clamping connection. Advantages: Simple, secure mounting even without torque wrench.

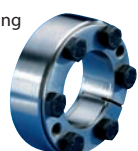

Catalogue 31.1

#### Three-part Shrink Discs

External clamping connection for the fastening of hollow shafts on solid shafts



Catalogue 31

#### Cone Clamping Elements

For shaft-hub connections. High torques with small dimensions.

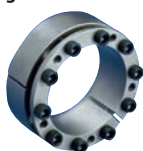

Catalogue 31

#### Star and Clamping Discs

Ideal for shaft-hub-connection for frequent release.



E03.023

#### Star Spring Washers

Axial spring element for preloading of ball bearings.



Catalogue 20

# RINGSPANN®

## Workholding Technology

### Precision Clamping Fixtures

#### Standard Parts for Clamping Fixtures

The RINGSPANN-System for the manufacture of your own precision clamping fixtures.

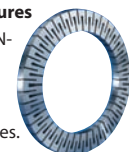

Catalogue 14

#### Standard Clamping Fixtures

Standard program in high precision, ready manufactured chucks and mandrels.



#### Special Clamping Fixtures

Custom made solutions for specific clamping problems.



#### Collet Mandrels

Universal, cost effective standard series. Fast collet change to other clamping diameters.



Catalogue 15

#### Hydraulic Expanding Clamping Tools

Mandrels and chucks with high concentricity. Clamping several workpieces in one process possible.



Catalogue 16



# RINGSPANN GmbH

Schaberweg 30-34  
61348 Bad Homburg

Telefon +49 6172 275-0  
Telefax +49 6172 275-275

www.ringspann.com  
mailbox@ringspann.com