

Cylindrical Roller Bearings **EW Series**

NSK has developed a higher load-carrying capacity pressed cage with low noise and superior cage strength. Our EW series is a standard cylindrical roller bearing that facilitates interchangeability across the globe, while offering better performance for every application.



Cylindrical Roller Bearing

EW Series

A newly developed standard bearing



Design concept of our newly developed standard bearing—the EW series

NSK has been supplying a standard cage for smaller-sized, single row cylindrical roller bearings as indicated here:

Standard bearings——W type (Pressed steel cage with flaps)

High load-carrying E type——ET type (Polyamide resin cage)

In the 21st century, you can now take advantage of NSK's newly developed cylindrical roller bearing, the EW series, which combines the strengths and technologies of previous cages into a one-piece steel cage.

NSK has achieved a new design involving even newer concepts, while maintaining excellence in function and service life. Our EW series can meet your high load-carrying capacity needs for the new era.

EW Series Bearing Interchange Guide

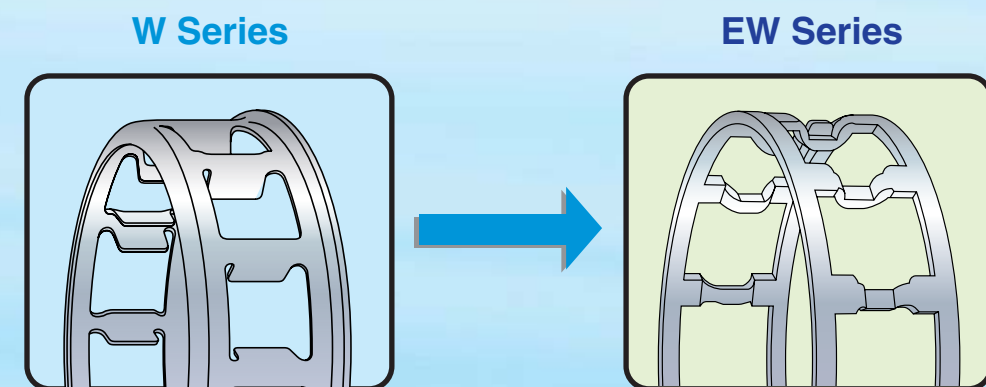
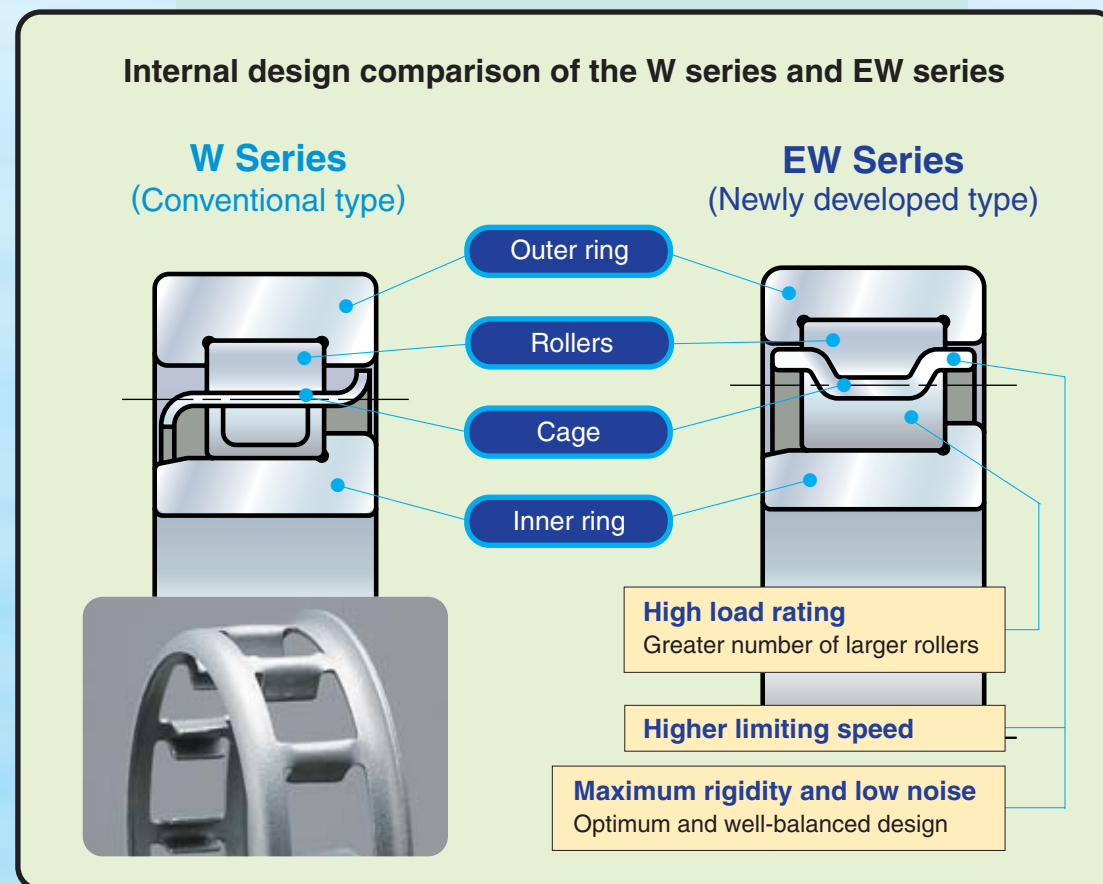

Results of FEM analysis

EW Series

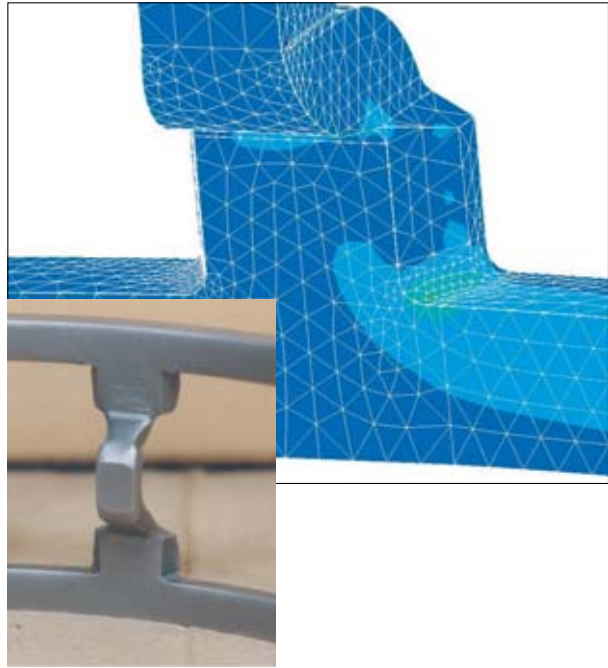

Conventional W Series

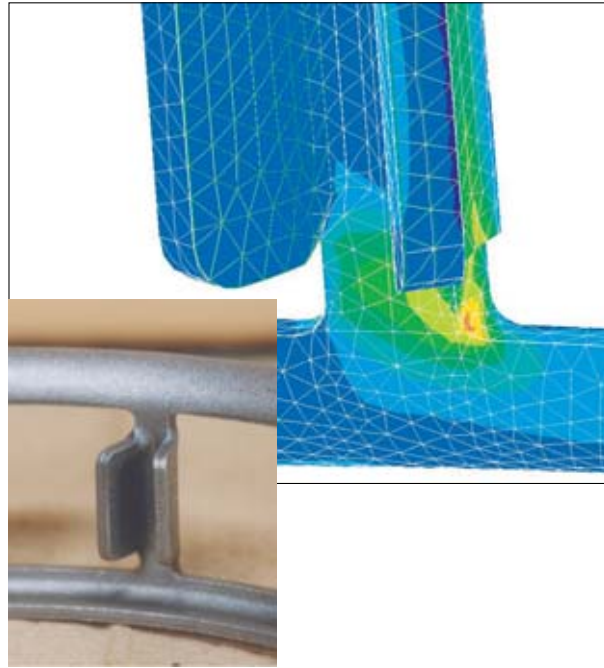

Tests confirm that the stress levels of NSK's EW series cages are 40% lower than that of cages in conventional W series.

Cage strength test results

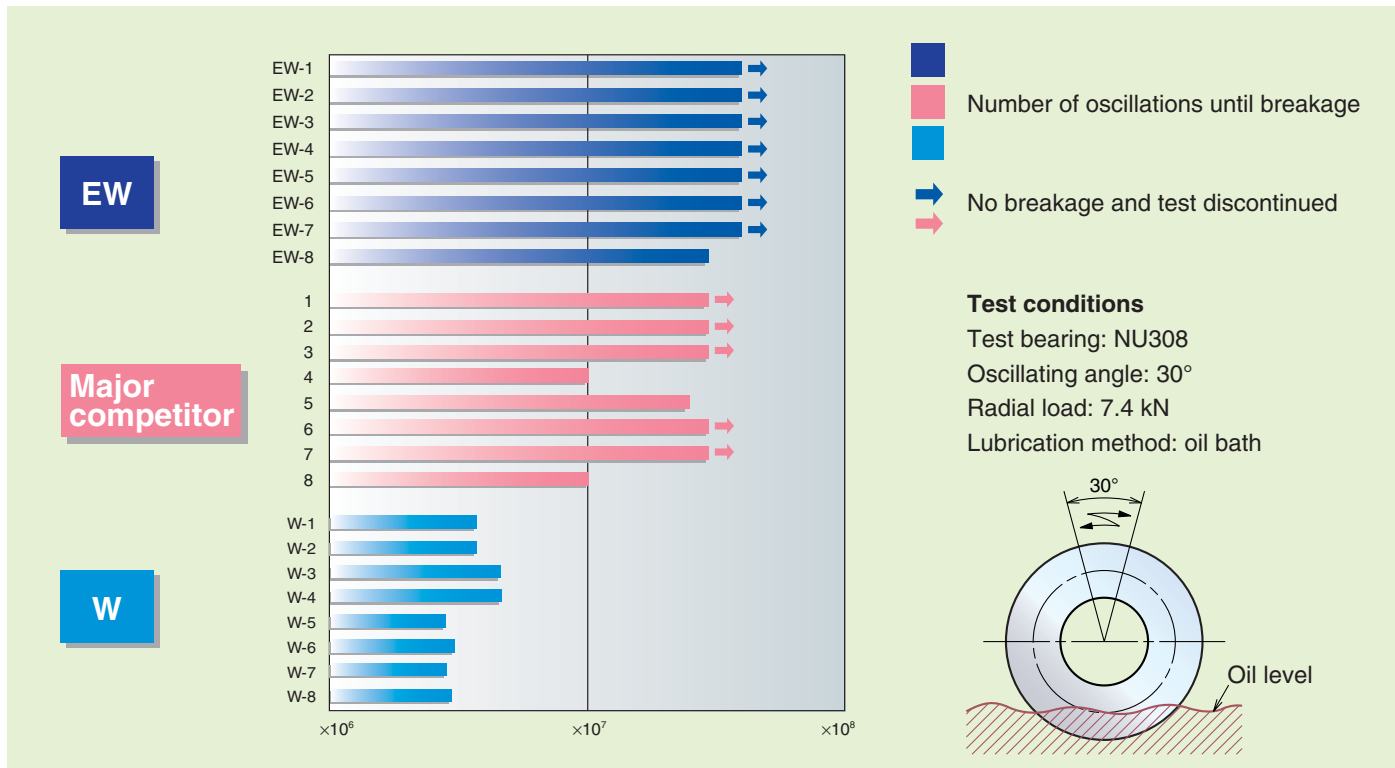

NSK's EW series showed greater cage strength performance than that of our major competitors.

Noise measurement test results

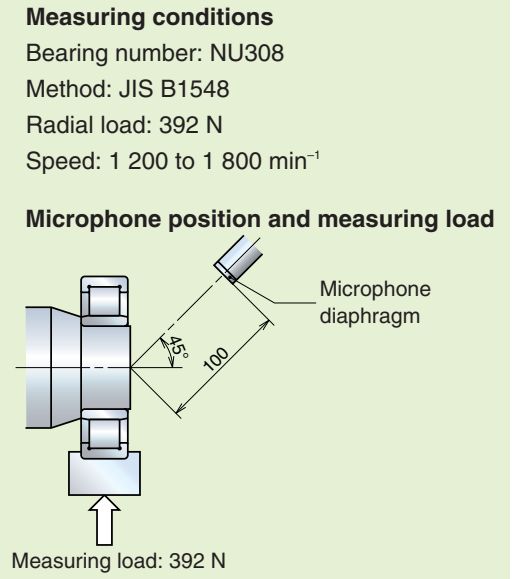
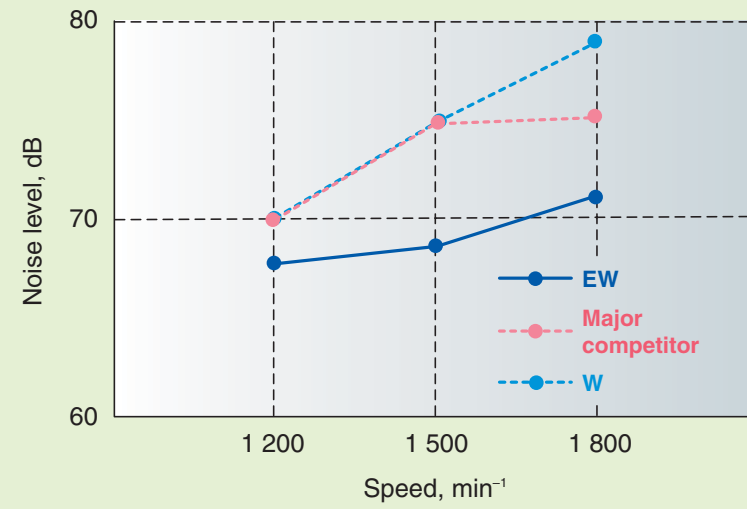

The EW series is 3 to 7 dB quieter than that of our major competitors.

Higher Limiting Speed

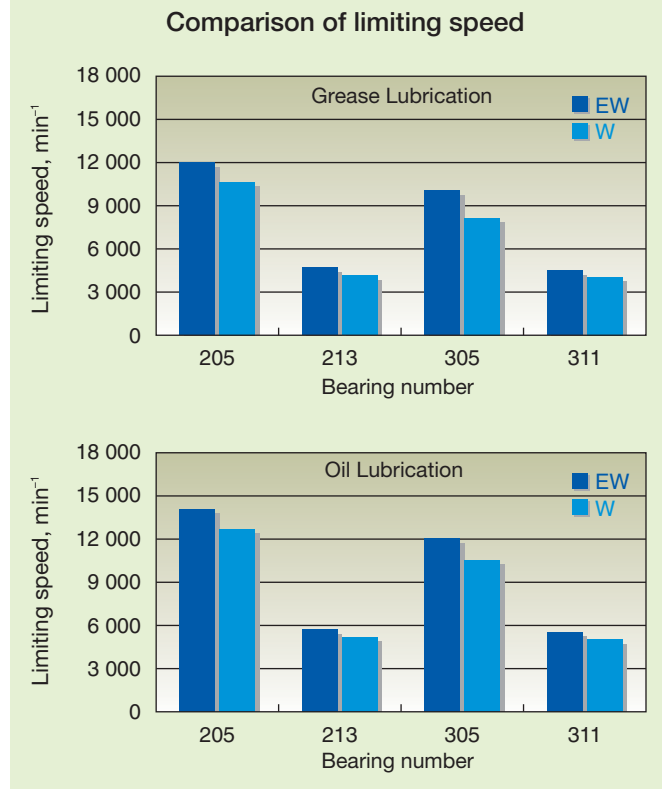

The limiting speed of the EW series is 10-25% higher than that of conventional W series.

Higher Load Rating

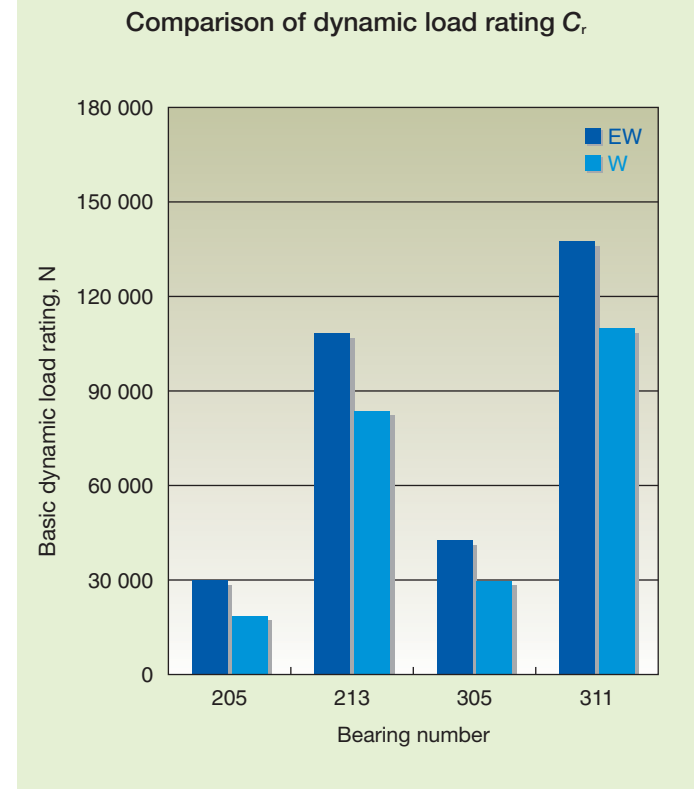

The load rating of the EW series is 10-60% higher than that of conventional W series.

EW Series Bearing Table

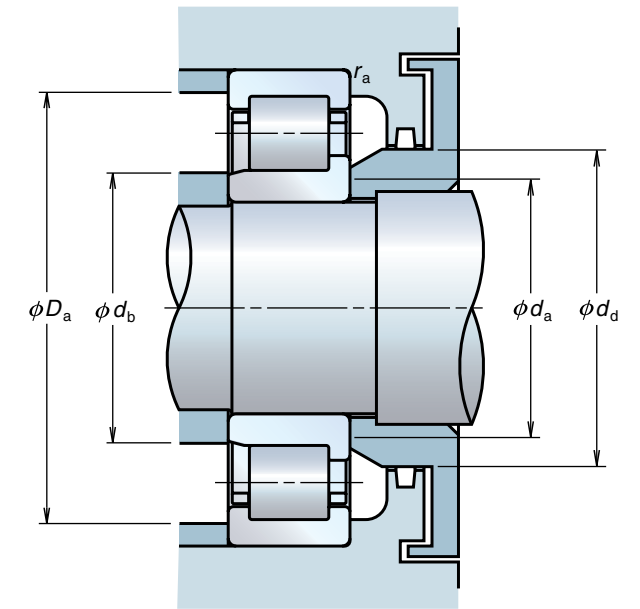
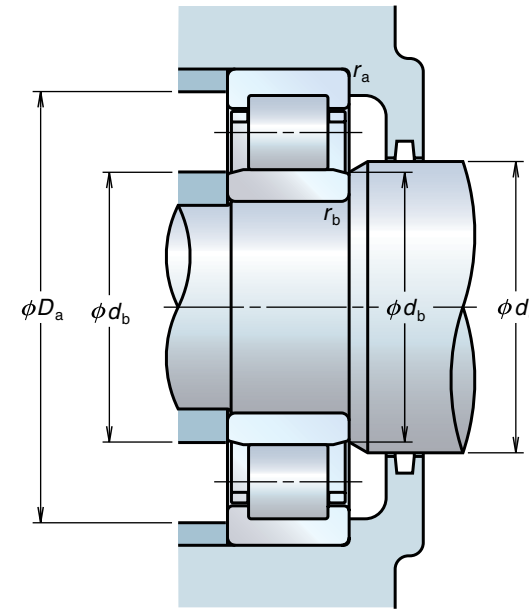
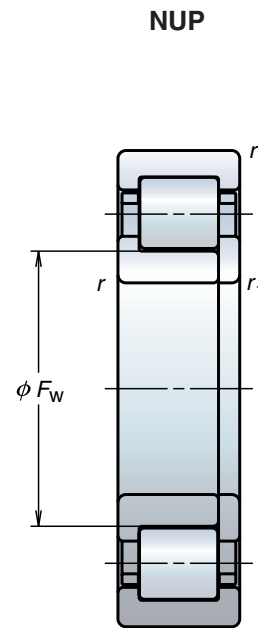
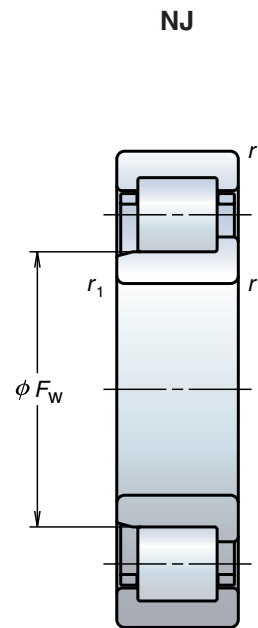
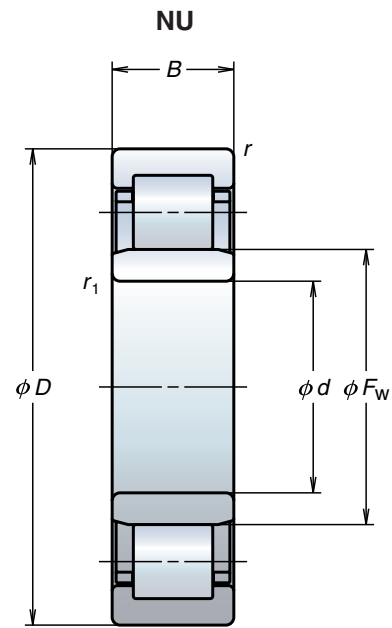

EW series 305-311 and 205-213 of NU, NJ, NUP.

d	Boundary Dimensions (mm)					Basic Load Ratings				Limiting Speeds [min ⁻¹]		Bearing Numbers			Abutment and Fillet Dimensions (mm)						Permissible Axial Movement (mm)		
	D	B	r min	r ₁ min	F _w	C _r [N]	C _{or}	C _r [kgf]	C _{or}	Grease	Oil	NU	NJ	NUP	d _a min	d _b min	d _b max	d _c min	d _d min	D _a max		r _a max	r _b max
25	52	15	1	0.6	31.5	29 300	27 700	2 990	2 830	12 000	14 000	NU205EW	NJ	NUP	30	29	30	34	37	47	1	0.6	1.2
	62	17	1.1	1.1	34	41 500	37 500	4 250	3 800	10 000	12 000	NU305EW	NJ	NUP	31.5	31.5	32	37	40	55.5	1	1	1.2
30	62	16	1	0.6	37.5	39 000	37 500	4 000	3 800	9 500	12 000	NU206EW	NJ	NUP	35	34	36	40	44	57	1	0.6	1.2
	72	19	1.1	1.1	40.5	53 000	50 000	5 400	5 100	8 500	10 000	NU306EW	NJ	NUP	36.5	36.5	39	44	48	65.5	1	1	1.2
35	72	17	1.1	0.6	44	50 500	50 000	5 150	5 100	8 500	10 000	NU207EW	NJ	NUP	41.5	39	42	46	50	65.5	1	0.6	1.2
	80	21	1.5	1.1	46.2	66 500	65 500	6 800	6 650	7 500	9 500	NU307EW	NJ	NUP	43	41.5	44	48	53	72	1.5	1	1.2
40	80	18	1.1	1.1	49.5	55 500	55 500	5 700	5 650	7 500	9 000	NU208EW	NJ	NUP	46.5	46.5	48	52	56	73.5	1	1	1.2
	90	23	1.5	1.5	52	83 000	81 500	8 500	8 300	6 700	8 000	NU308EW	NJ	NUP	48	48	50	55	60	82	1.5	1.5	1.2
45	85	19	1.1	1.1	54.5	63 000	66 500	6 450	6 800	6 700	8 000	NU209EW	NJ	NUP	51.5	51.5	52	57	61	78.5	1	1	1.2
	100	25	1.5	1.5	58.5	97 500	98 500	9 950	10 000	6 000	7 500	NU309EW	NJ	NUP	53	53	56	60	66	92	1.5	1.5	1.4
50	90	20	1.1	1.1	59.5	69 000	76 500	7 050	7 800	6 300	7 500	NU210EW	NJ	NUP	56.5	56.5	57	62	67	83.5	1	1	1.7
	110	27	2	2	65	110 000	113 000	11 200	11 500	5 000	6 000	NU310EW	NJ	NUP	59	59	63	67	73	101	2	2	1.4
55	100	21	1.5	1.1	66	86 500	98 500	8 800	10 100	5 600	7 100	NU211EW	NJ	NUP	63	61.5	64	68	73	92	1.5	1	1.2
	120	29	2	2	70.5	137 000	143 000	14 000	14 600	4 500	5 600	NU311EW	NJ	NUP	64	64	68	72	80	111	2	2	1.4
60	110	22	1.5	1.5	72	97 500	107 000	9 950	10 900	5 300	6 300	NU212EW	NJ	NUP	68	68	70	75	80	102	1.5	1.5	1.2
65	120	23	1.5	1.5	78.5	108 000	119 000	11 000	12 100	4 800	5 600	NU213EW	NJ	NUP	73	73	76	81	87	112	1.5	1.5	1.4

Worldwide Sales Offices

NSK LTD.-HEADQUARTERS, TOKYO, JAPAN www.nsk.com INDUSTRIAL MACHINERY BUSINESS DIVISION-HEADQUARTERS tel: 03-3779-7227 GLOBAL AFTERMARKET DEPARTMENT tel: 03-3779-7253 PRECISION MACHINERY DEPARTMENT tel: 03-3779-7163 MECHATRONICS BUSINESS DEPARTMENT tel: 0466-21-3027 AUTOMOTIVE BUSINESS DIVISION-HEADQUARTERS tel: 03-3779-7189	Indonesia: PT. NSK INDONESIA Jakarta tel: 021-252-3458	Poland: NSK EUROPE LTD. WARSAW LIAISON OFFICE Warsaw tel: 022-645-1525 NSK EUROPEAN TECHNOLOGY CENTER, POLAND OFFICE Kielce tel: 041-367-0940 NSK STEERING SYSTEMS EUROPE (POLSKA) SP.ZO.O. Walbrzych tel: 074-664-4101 NSK NEEDLE BEARING POLAND SP.ZO.O. Kielce tel: 041-345-2469 NSK POLSKA SP.ZO.O. Kielce tel: 041-347-5110
Africa South Africa: NSK SOUTH AFRICA (PTY) LTD. Johannesburg tel: 011-458-3600	Korea: NSK KOREA CO., LTD. Seoul Changwon tel: 02-3287-0300 tel: 055-287-6001	Spain: NSK SPAIN S.A. Barcelona tel: 093-433-5775
Asia and Oceania Australia: NSK AUSTRALIA PTY. LTD. www.au.nsk.com Melbourne tel: 03-9764-8302	Malaysia: NSK BEARINGS (MALAYSIA) SDN.BHD. www.my.nsk.com Shah Alam tel: 03-7803-8859	Turkey: NSK RULMANLARI ORTA DOGU TIC. LTD. STI. Istanbul tel: 0126-355-0398
China: NSK HONG KONG LTD. Hong Kong tel: 02739-9933 Shenzhen tel: 0755-25904886	New Zealand: NSK NEW ZEALAND LTD. www.nsk-rhp.co.nz Auckland tel: 09-276-4992	United Kingdom: NSK EUROPEAN TECHNOLOGY CENTRE Newark tel: 01636-605-123 NSK UK Ltd. Newark tel: 01636-605-123 NSK PRECISION UK LTD. Newark tel: 01636-605-123 NSK STEERING SYSTEMS EUROPE LTD. Maidenhead tel: 01628-509-800
KUNSHAN NSK CO., LTD. Kunshan tel: 0512-5771-5654	Philippines: NSK REPRESENTATIVE OFFICE Manila tel: 02-893-9543	North and South America NSK AMERICAS, INC. (AMERICAN HEADQUARTERS) Ann Arbor tel: 734-913-7500
CHANGSHU NSK NEEDLE BEARING CO., LTD. Jiangsu tel: 0512-5230-1111	Singapore: NSK INTERNATIONAL (SINGAPORE) PTE LTD. Singapore tel: 6496-8000 NSK SINGAPORE (PRIVATE) LTD. www.nsk-singapore.com.sg Singapore tel: 6496-8000	Argentina: NSK ARGENTINA SRL Buenos Aires tel: 11-4704-5100
NSK STEERING SYSTEMS DONGGUAN CO., LTD. Dongguan tel: 0769-2262-0960	Taiwan: TAIWAN NSK PRECISION CO., LTD. Taipei tel: 02-2509-3305 TAIWAN NSK TECHNOLOGY CO., LTD. Taipei tel: 02-2509-3305	Brazil: NSK BRASIL LTDA. www.br.nsk.com São Paulo tel: 011-3269-4786
NSK (CHINA) RESEARCH & DEVELOPMENT CO., LTD. Jiangsu tel: 0512-5796-3000	Thailand: NSK BEARINGS (THAILAND) CO., LTD. Bangkok tel: 02320-2555 SIAM NSK STEERING SYSTEMS CO., LTD. Chachoengsao tel: 038-522-343 NSK ASIA PACIFIC TECHNOLOGY CENTER (THAILAND) CO., LTD. Chonburi tel: 038-454-631	Canada: NSK CANADA INC. www.ca.nsk.com Toronto tel: 905-890-0740
NSK (SHANGHAI) TRADING CO., LTD. Jiangsu tel: 0512-5796-3000	Vietnam: NSK VIETNAM CO., LTD. Hanoi tel: 04-3955-0159	Mexico: NSK RODAMIENTOS MEXICANA, S.A. DE C.V. www.mx.nsk.com Mexico City tel: 55-3682-2900
NSK (CHINA) INVESTMENT CO., LTD. Jiangsu tel: 0512-5796-3000	NSK REPRESENTATIVE OFFICE Ho Chi Minh City tel: 08-3822-7907	United States of America: NSK CORPORATION www.us.nsk.com Ann Arbor tel: 734-913-7500 NSK AMERICAN TECHNOLOGY CENTER Ann Arbor tel: 734-913-7500 NSK PRECISION AMERICA, INC. www.npa.nsk.com Franklin tel: 317-738-5000 NSK STEERING SYSTEMS AMERICA, INC. www.nssa.nsk.com Bennington tel: 802-442-5448 NSK LATIN AMERICA, INC. www.la.nsk.com Miami tel: 305-477-0605
NSK CHINA SALES CO., LTD. Jiangsu tel: 0512-5796-3000	Europe NSK EUROPE LTD. (EUROPEAN HEADQUARTERS) www.eu.nsk.com Maidenhead tel: 01628-509-800	<As of July 2010>
NSK (SHANGHAI) TRADING CO., LTD. Jiangsu tel: 0512-5796-3000	France: NSK FRANCE S.A.S. Paris tel: 01-30-57-39-39	For the latest information, please refer to the NSK website.
NSK (CHINA) INVESTMENT CO., LTD. Beijing tel: 010-6590-8161	Germany: NSK DEUTSCHLAND GMBH Düsseldorf tel: 02102-4810 NSK PRECISION EUROPE GMBH Düsseldorf tel: 02102-4810	
NSK (CHINA) INVESTMENT CO., LTD. Guangzhou tel: 020-3786-4833	Italy: NSK ITALIA S.P.A. Milano tel: 0299-5191	
NSK (CHINA) INVESTMENT CO., LTD. Chengdu tel: 028-8661-4200		
NSK (CHINA) INVESTMENT CO., LTD. Shenyang tel: 024-2334-2868		
NSK (CHINA) INVESTMENT CO., LTD. Dalian tel: 0411-8800-8168		
NSK CHINA SALES CO., LTD. Changchun tel: 0431-8898-8682		
NSK CHINA SALES CO., LTD. Tianjin tel: 022-8319-5030		
NSK CHINA SALES CO., LTD. Nanjing tel: 025-8472-6671		
NSK CHINA SALES CO., LTD. Chongqing tel: 023-6806-5310		
India: RANE NSK STEERING SYSTEMS LTD. Chennai tel: 044-474-06017		
NSK INDIA SALES CO. PVT. LTD. Chennai tel: 044-2433-1161		
NSK INDIA SALES CO. PVT. LTD. Gurgaon tel: 0124-4104-530		
NSK INDIA SALES CO. PVT. LTD. Kolkata tel: 033-4001-2062		
NSK INDIA SALES CO. PVT. LTD. Mumbai tel: 022-2838-7787		
NSK-ABC BEARINGS LTD. Chennai tel: 044-2714-3000		

NSK Ltd. has a basic policy not to export any products or technology designated as controlled items by export-related laws. When exporting the products in this brochure, the laws of the exporting country must be observed. Specifications are subject to change without notice and without any obligation on the part of the manufacturer. Every care has been taken to ensure the accuracy of the data contained in this brochure, but no liability can be accepted for any loss or damage suffered through errors or omissions. We will gratefully acknowledge any additions or corrections.

For more information about NSK products, please contact: _____

