



FAG



added
competence

Double row axial angular contact ball bearings for screw drives

Series ZKLN..-DAC

SCHAEFFLER GROUP
INDUSTRIAL



added
competence

**The right product
for every application**

=

**Optimum benefit
for you**

With their forward-looking bearing arrangement solutions for feed spindles, main spindles, rotary tables and linear guidance units, INA and FAG have been at the forefront of the world market for decades. The bearing components alone, however, are often no longer the decisive factor for these machine subsystems.

Our customers have of course benefitted directly from significant performance improvements and unique selling propositions thanks to our “ready-to-fit” products; these compact, ready-to-fit bearings are used in accordance with the simple principle: unpack, screw mount, use. In order to optimise the entire machine tool system, however, it is becoming ever more important not simply to support the subsystems but to integrate important functions such as measurement, sealing, lubrication, braking etc. in the components themselves. This intellectual approach is fulfilled comprehensively by the new concept **added competence** in the Production Machinery Sector since it attaches central importance to systems solution thinking for the bearing, bearing position and entire system. This means that you can now access a product range that gives optimum coverage to all your applications in the machine tool.

Since direct drives and mechatronic solutions are used ever more frequently in machine tools, we have incorporated a further strong partner in the form of IDAM – INA Drives & Mechatronics – in our spectrum of capabilities. In this way, we can now supply you from a single source with bearing elements and the appropriate drive system to give complete systems that are precisely matched to each other. This opens up completely new technical and economic design possibilities for your requirements as well as significant advantages in the time and process chain.

In terms of products, we offer you a comprehensive, precisely balanced range, precision technology and top product quality. In order to match the pulse of your developments as closely as possible, furthermore, we have a worldwide network of engineers, service and sales technicians working for you and ensuring that we maintain close contact with you in your own location.

In conclusion, we are convinced that we will always have the right product for your application. Just contact us to see what we can do for you.

added
competence

Double row axial angular contact ball bearings for screw drives

Features Bearings of series ZKLN.-DAC are double row, self-retaining axial angular contact ball bearings. Due to the 60° contact angle, they can support radial forces clearance-free and high axial forces from both sides.

Sealing/lubrication Due to the non-contact minimal gap seals integrated in the standard design envelope and greasing with a lithium soap grease to GA28, these bearings are maintenance-free and are thus particularly economical (for information on GA28, see TPI 123). There is therefore no need for lubricant feeds, separate seal contact rings or seals. This reduces the number of components, the mounting requirements, the costs of producing adjacent components, the design envelope required and the risk of errors in mounting work, *Figure 3*, page 7.

The gap seals give low bearing friction and allow high speeds with little heat generation in the bearing.

Due to the high quality FPM material, the seals are extremely resistant to aggressive media – such as oils and cooling lubricants – and thus increase the long term operational reliability of the bearing arrangement.

Operating temperature Sealed axial angular contact ball bearings are suitable for operating temperatures from –30 °C to +120 °C; this is limited by the grease, seal material and the plastic cages in the ball and cage assemblies.

Caution! The operating temperature influences the dynamic bearing characteristics. The values given in the dimension table are based on a room temperature of +20 °C.

Design and safety guidelines

Load carrying capacity and rating life

Bearings of series ZKLN...-DAC are optimised in relation to axial load carrying capacity and life. Since maximum use is made of the design envelope, high axial load carrying capacity and rigidity is achieved. Under comparable loads, this gives longer bearing arrangement life compared to bearings generally available on the market, *Figure 1*.

- d = bore diameter of inner ring
 ① Bearing arrangement with ZKLN...-DAC
 ② Competitor bearing arrangement

Figure 1

Life comparison of ZKLN...-DAC/
 competitor bearing arrangement

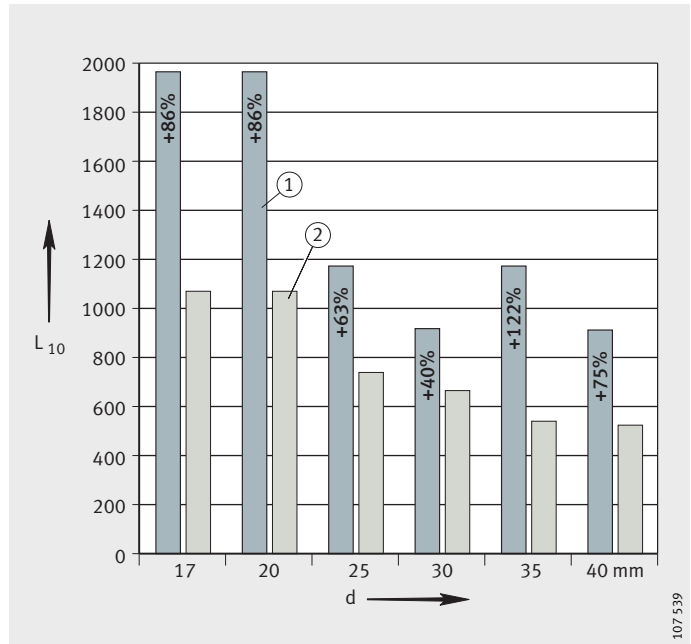

Life calculation

The formulae for calculating the basic rating life L_h are given in TPI 123. Calculation of the resultant and equivalent bearing load required for life calculation is described in the following paragraph and *Figure 2*.

Resultant and equivalent bearing load P

The bearings are axially preloaded to a defined value if the recommended precision locknuts are used and the correct nut tightening torque is applied. The resultant axial bearing load $F_{a\text{res}}$ is determined from the axial operating load F_{aB} and taking account of the axial preload according to *Figure 2*.

Caution!

A load in excess of the limit value will lead to the rolling element row without load lifting off the raceway; for limit values see *Figure 2*. As a result, higher wear will occur under rapid acceleration.

For extreme moment loads and statically overdefined systems (locating/locating bearing arrangements), please contact us. The calculation program BEARINX[®] can give a precise design in this case.

Double row axial angular contact ball bearings for screw drives

F_{aB} = operating load
 $F_{a\ res}$ = resultant bearing load
 $^{\circ}$ = limit value

Figure 2
 Resultant bearing load
 with ZKLN...-DAC

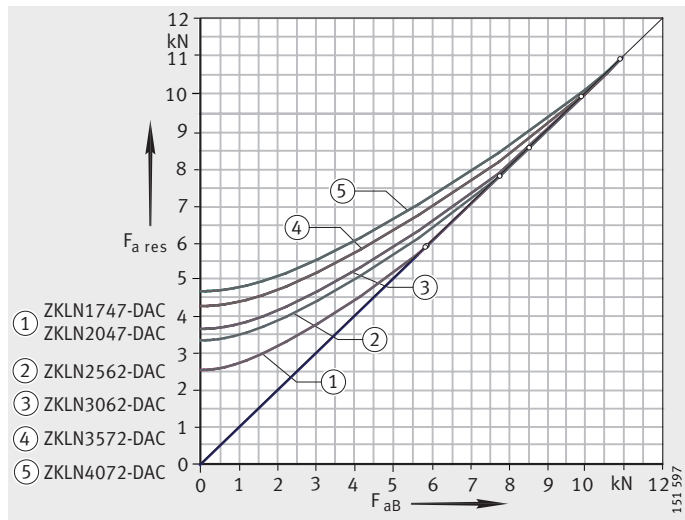

Static load safety factor

The static load safety factor S_0 indicates the security against permissible permanent deformations in the bearing. Calculation of the static load safety factor is described in TPI 123.

In machine tools, S_0 should be > 4 .

Speeds

The thermal reference speed is the speed at which an equilibrium temperature of $+70\text{ }^{\circ}\text{C}$ is calculated to be reached at a room temperature of $+20\text{ }^{\circ}\text{C}$.

Practically relevant limiting speed for applications in machine tools

In machine tools, it is normal practice to aim for a maximum permissible bearing temperature of $+50\text{ }^{\circ}\text{C}$. This is necessary in order to minimise the influence of heat generation on machine accuracy. The dimension tables therefore indicate practically relevant limiting speeds for machine tool applications that are below the achievable bearing speed. These limiting speeds are based on the following conditions:

- bearing preloaded, no external operating load
- 25% operating duration
- max. equilibrium temperature $+50\text{ }^{\circ}\text{C}$.

If the speed is to be determined for a different application or higher speeds are necessary, a thermal balance analysis can be carried out. Please contact INA/FAG in this case.

Design of adjacent construction

Adjacent constructions (the shaft and housing) must be designed in accordance with the data in the dimension tables.

The abutment diameters for the shaft and housing shoulders d_a and D_a must be in accordance with the dimension tables.

Caution!

D_a and d_a are recommended minimum abutment diameters. If these values are not used, rib diameters d_1 , D_1 according to the dimension table must be observed.

Mounting guidelines

Caution!

Bearings should only be fitted and dismantled in accordance with the Fitting and Maintenance Manual TPI 100. This TPI is available upon request.

During fitting of bearings, mounting forces should be applied only to the bearing ring to be fitted. Mounting forces must never be directed through the rolling elements or sealing rings.

The characteristics of the bearings are only valid when used in combination with INA precision locknuts and the associated tightening torques given in the dimension table.

Axial angular contact ball bearings are self-retaining and the individual bearing components are matched to each other. The inner rings must not be removed from the bearing during fitting and dismantling. If the inner rings have been separated from the bearing, please contact INA/FAG. Never use force to fit the bearing parts. This can lead to plastic deformations in the rolling element system that may render the bearing unusable.

Location of inner ring

When clamping the inner rings using the recommended precision locknut, the tightening torques given in the dimension tables must be observed, *Figure 3*. The tightening torques for the individual bearing sizes are only valid for the INA precision locknuts listed.

In order to counteract settling, it is recommended that the locknut should initially be tightened to twice the tightening torque M_A and then relieved of load again. It should only then be tightened again to the necessary tightening torque M_A .

Caution!

If other suitable locknuts are used, the manufacturer's guidance on calculation of the necessary tightening torque should be observed. Only locknuts with a minimum accuracy of the end face to the thread of 5 μm should be used.

① Locknut

Figure 3

Location of outer ring using a cover, preloaded using locknut

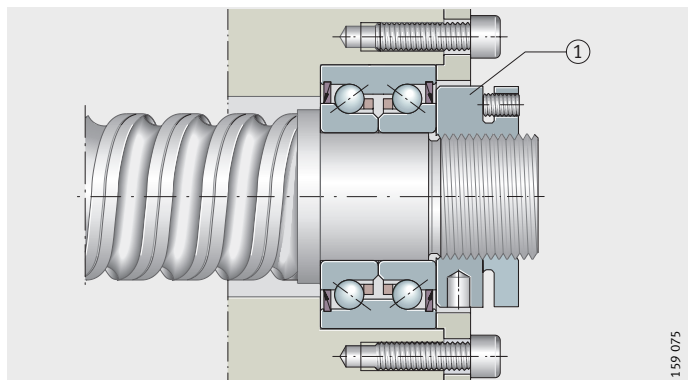

Double row axial angular contact ball bearings

Double direction
Sealed on both sides

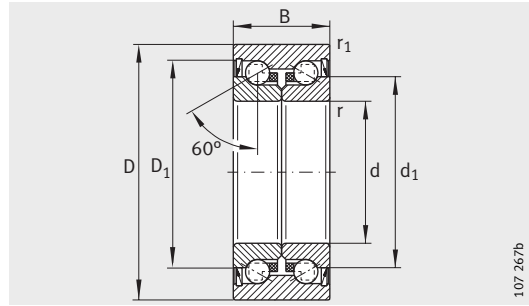

ZKLN...-DAC

Dimension table · Dimensions in mm

Designation	Mass ≈kg	Dimensions							Mounting dimensions		Basic load ratings axial	
		d -0,005	d ₁	D -0,01	D ₁	B -0,25	r min.	r ₁ min.	D _a H12	d _a min.	dyn. C _a N	stat. C _{0a} N
ZKLN1747-DAC	0,27	17	34,5	47	44	30	1	0,6	43	23	26 000	47 000
ZKLN2047-DAC	0,25	20	34,5	47	44	30	1	0,6	43	25	26 000	47 000
ZKLN2562-DAC	0,48	25	45,5	62	54	30	1	0,6	53	40	29 000	64 000
ZKLN3062-DAC	0,43	30	45,5	62	54	30	1	0,6	53	40	29 000	64 000
ZKLN3572-DAC	0,58	35	56	72	66	30	1	0,6	67	52	37 000	89 000
ZKLN4072-DAC	0,51	40	56	72	66	30	1	0,6	67	52	37 000	89 000

1) For applications in machine tools.

2) Only valid in conjunction with INA precision locknuts.

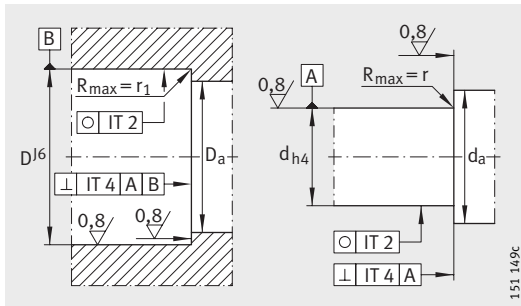

Design of adjacent construction

Speeds		Rigidity axial c_{aL} N/ μ m	Bearing frictional torque M_{RL} Nm	Run-out μ m	Recommended INA locknut; to be ordered separately			
Limiting speed n_G grease min ⁻¹	Practically relevant limiting speed ¹⁾ n_G grease min ⁻¹				Designation	Tightening torque ²⁾ M_A Nm	Preload force N	
6 000	5 400	764	0,2	2	ZM17	AM17	18	8 980
6 200	5 400	764	0,2	2	ZM20	AM20	18	8 980
5 400	4 300	1001	0,25	2	ZMA25/45	AM25	30	11 810
5 100	4 300	1034	0,25	2,5	ZM30	AM30	32	11 080
4 700	3 850	1196	0,35	2,5	ZMA35/58	AM35	50	15 220
4 700	3 850	1235	0,35	2,5	ZM40	AM40	60	15 650

Schaeffler KG

Industriestrasse 1–3
91074 Herzogenaurach (Germany)
Internet www.ina.com
E-Mail Info@de.ina.com

In Germany:

Phone 0180 5003872
Fax 0180 5003873

From Other Countries:

Phone +49 9132 82-0
Fax +49 9132 82-4950

Schaeffler KG

Georg-Schäfer-Strasse 30
97421 Schweinfurt (Germany)
Internet www.fag.com
E-Mail FAGdirect@de.fag.com

In Germany:

Phone 0180 5003872
Fax 0180 5003873

From Other Countries:

Phone +49 9721 91-0
Fax +49 9721 91-3435

Every care has been taken to ensure the correctness of the information contained in this publication but no liability can be accepted for any errors or omissions. We reserve the right to make changes in the interest of technical progress.

© Schaeffler KG · 2006, May

This publication or parts thereof may not be reproduced without our permission.